



An Oshkosh Corporation Company

Service & Maintenance Manual

Model(s) **15/20MVL & 15/20MSP Series**

P/N - 3121231

December 20, 2013

ANSI

CE



MAINTENANCE SAFETY PRECAUTIONS

A. GENERAL

This section contains the general safety precautions which must be observed during maintenance of the aerial platform. It is of utmost importance that maintenance personnel pay strict attention to these warnings and precautions to avoid possible injury to themselves or others or damage to the equipment. A maintenance program must be established by a qualified person and must be followed to ensure that the machine is safe to operate.

⚠ WARNING

MODIFICATION OF THE MACHINE WITHOUT CERTIFICATION BY A RESPONSIBLE AUTHORITY THAT THE MACHINE IS AT LEAST AS SAFE AS ORIGINALLY MANUFACTURED IS A SAFETY VIOLATION.

The specific precautions to be observed during machine maintenance are inserted at the appropriate point in the manual. These precautions are, for the most part, those that apply when servicing hydraulic and larger machine component parts.

Your safety, and that of others, is the first consideration when engaging in the maintenance of equipment. Always be conscious of component weight and never attempt to move heavy parts without the aid of a mechanical device. Do not allow heavy objects to rest in an unstable position. When raising a portion of the equipment, ensure that adequate support is provided.

⚠ WARNING

SINCE THE MACHINE MANUFACTURER HAS NO DIRECT CONTROL OVER THE FIELD INSPECTION AND MAINTENANCE, SAFETY IN THIS AREA IS THE RESPONSIBILITY OF THE OWNER/ OPERATOR.

B. HYDRAULIC SYSTEM SAFETY

1. It should be particularly noted that the machines hydraulic systems operate at extremely high and potentially dangerous pressures. Every effort should be made to relieve any system pressure prior to disconnecting or removing any portion of the system.
2. Relieve system pressure by lowering the platform completely to direct any line pressure back into the return line to the reservoir. Pressure feed lines to system components can then be disconnected with minimal fluid loss.

C. MAINTENANCE

⚠ WARNING

FAILURE TO COMPLY WITH SAFETY PRECAUTIONS LISTED IN THIS SECTION COULD RESULT IN MACHINE DAMAGE, PERSONNEL INJURY OR DEATH AND IS A SAFETY VIOLATION.

- REMOVE ALL RINGS, WATCHES, AND JEWELRY WHEN PERFORMING ANY MAINTENANCE.
- DO NOT WEAR LONG HAIR UNRESTRAINED, OR LOOSE FITTING CLOTHING AND NECKTIES WHICH ARE APT TO BECOME CAUGHT ON OR ENTANGLED IN EQUIPMENT.
- OBSERVE AND OBEY ALL DANGER, WARNING, CAUTION AND OTHER INSTRUCTIONS ON MACHINE AND IN SERVICE MANUAL.
- KEEP STANDING SURFACES AND HAND HOLDS FREE OF OIL, GREASE, WATER, ETC.
- NEVER WORK UNDER AN ELEVATED PLATFORM UNTIL PLATFORM HAS BEEN SAFELY RESTRAINED FROM ANY MOVEMENT BY BLOCKING OR OVER-HEAD SLING.
- BEFORE MAKING ADJUSTMENTS, LUBRICATING OR PERFORMING ANY OTHER MAINTENANCE, SHUT OFF ALL POWER CONTROLS.
- BATTERY SHOULD ALWAYS BE DISCONNECTED DURING REPLACEMENT OF ELECTRICAL COMPONENTS.
- KEEP ALL SUPPORT EQUIPMENT AND ATTACHMENTS STOWED IN THEIR PROPER PLACE.
- USE ONLY APPROVED, NONFLAMMABLE CLEANING SOLVENTS.
- ENSURE REPLACEMENT PARTS OR COMPONENTS ARE IDENTICAL OR EQUIVALENT TO ORIGINAL PARTS OR COMPONENTS.

REVISION LOG

Original Issue of Manual January 5, 2006
Manual Revised April 3, 2006
Manual Revised October 4, 2006
Manual Revised October 8, 2007
Manual Revised April 17, 2008
Manual Revised October 7, 2008
Manual Revised May 15, 2009
Manual Revised July 19, 2010
Manual Revised December 21, 2010
Manual Revised February 23, 2012
Manual Revised April 25, 2013
Manual Revised December 5, 2013
Manual Revised December 20, 2013

TABLE OF CONTENTS

SUBJECT - SECTION, PARAGRAPH	PAGE NO.
MAINTENANCE SAFETY PRECAUTIONS	A
A GENERAL	A
B HYDRAULIC SYSTEM SAFETY	A
C MAINTENANCE	A
REVISION LOG	B
 SECTION 1 - MACHINE SPECIFICATIONS	
1.1 CAPACITIES	1-2
System Voltage	1-2
Hydraulic System	1-2
Drive Motor GearBox (gear oil)	1-2
1.2 COMPONENT DATA	1-2
Hydraulic Pump/Pump Motor Assembly	1-2
Rear Wheel Drive Motors	1-2
Batteries/Battery Charger	1-2
1.3 PERFORMANCE DATA	1-2
Platform Capacities	1-2
Platform Size	1-2
Machine Height (platform stowed)	1-2
Machine Ground Clearance	1-2
Base Footprint	1-2
1.4 LUBRICATION	1-4
Hydraulic Oil	1-4
Lubrication Specifications	1-4
1.5 CYLINDER SPECIFICATIONS	1-4
1.6 SERIAL NUMBER LOCATIONS	1-4
1.7 TORQUE REQUIREMENTS	1-4
 SECTION 2 - GENERAL	
2.1 MACHINE PREPARATION, INSPECTION, AND MAINTENANCE	2-1
General	2-1
Preparation, Inspection, and Maintenance	2-1
Pre-Start Inspection	2-1
Pre-Delivery Inspection and Frequent Inspection	2-1
Annual Machine Inspection	2-1
Preventative Maintenance	2-1
2.2 PREVENTIVE MAINTENANCE AND INSPECTION SCHEDULE	2-2
Inspection and Maintenance Codes:	2-4
Footnotes:	2-4
2.3 SERVICING AND MAINTENANCE GUIDELINES	2-5
General	2-5
Safety and Workmanship	2-5
Cleanliness	2-5
Components Removal and Installation	2-5
Component Disassembly and Reassembly	2-5
Pressure-Fit Parts	2-5
Bearings	2-5
Gaskets	2-5
Bolt Usage and Torque Application	2-5
Hydraulic Lines and Electrical Wiring	2-6

TABLE OF CONTENTS

Hydraulic System	2-6
Lubrication and Servicing	2-6
Batteries	2-6
Mast Chain Inspection Procedure	2-6
2.4 LUBRICATION INFORMATION	2-8
Hydraulic System	2-8
Hydraulic Oil	2-8
Changing Hydraulic Oil	2-8
Lubrication Specifications	2-8

SECTION 3 - BASE COMPONENTS

3.1 BASE ASSEMBLY COMPONENTS	3-1
3.2 BASE FRAME COVERS	3-2
Drive Motor Cover - Installation	3-2
Battery Charger Cover - Installation	3-2
3.3 DRIVE/ELEVATION CUT-OUT SWITCH INSTALLATION	3-2
3.4 DRIVE AND CASTER WHEELS	3-3
Tire Wear and Damage	3-3
Wheel and Tire Replacement	3-3
Wheel Installation	3-3
Caster Wheels - Installation	3-3
3.5 WHEEL DRIVE ASSEMBLY - SERVICING	3-4
Roll And Leak Testing	3-4
Oil Type & Capacity	3-4
Drive Motor Brush Wear - Warning Indication	3-4
Wheel Drive Assembly - Removal From Machine	3-5
Wheel Drive Disassembly - Main Components	3-6
Replacing Drive Motor Brushes	3-7
Gear Box Main Disassembly	3-9
Input Carrier Disassembly	3-10
Hub - Disassembly	3-11
Spindle Disassembly	3-12
Spindle Sub-Assembly	3-13
Hub Sub-Assembly	3-14
Input Carrier Sub-Assembly	3-15
Main Gear Box Sub-Assembly	3-16
Motor, Brake and Gear Box Assembly	3-17
3.6 POT HOLE PROTECTION SYSTEM	3-18
3.7 BATTERY CHARGER - SERVICE PROCEDURES	3-20
Battery Charger General Information	3-20
Battery Charger Maintenance Information	3-20
Battery Charge LED Indicator on Platform Control Console	3-20
Battery Low Voltage Warning Indicators	3-20
Battery Charging Status Indicators	3-21
Battery Charger Check/Change Charging Algorithm	3-22
Battery Charger Removal/Installation	3-22

SECTION 4 - CONTROL COMPONENTS

4.1 CONTROL COMPONENTS OVERVIEW	4-1
4.2 CONTROLS COVER INSTALLATION	4-2
Battery Cover Doors (Optional Hinged)	4-2
Center, Left and Right Lower Covers	4-2
4.3 CONTROL COMPONENTS - INSTALLATION	4-3
Ground Control Module	4-3

	Traction Control Module	4-3
	Platform Control Console Installation	4-4
	Horn Installation	4-4
	Alarm Installation	4-4
4.4	BATTERIES - SERVICE PROCEDURES	4-5
	Battery Condition Testing	4-5
	Battery Replacement	4-5
	Battery Disconnect (Option)	4-5
	Battery - Installation - (2-12V Batteries)	4-5
	Battery Installation - (4-6V Batteries) (OPTION)	4-7
4.5	GROUND CONTROL MODULE - SERVICE PROCEDURE	4-8
	Cover Removal/Installation	4-9
	Power Selector/EStop Switch Installation	4-10
4.6	GROUND CONTROL MODULE - PROGRAMMING	4-11
	General	4-11
	Programming Levels	4-11
	Activating Programming Mode	4-11
	Entering Password	4-12
	Programming Mode Selection	4-12
	Selecting Programmable Item to Adjust	4-12
	Adjusting Programmable Setting	4-12
	Service Programming Mode - (Level-2)	4-13
	Operator Programming Mode - (Level-3)	4-14
4.7	PLATFORM CONTROL CONSOLE - SERVICE PROCEDURES	4-16
	General	4-16
	Remove Platform Control Console	4-16
	Display/Controller Module Electrical Connections	4-17
	Mounting Bracket - Install/Remove	4-17
	Rear Cover - Install/Remove	4-17
	Display/Controller Module - Install/Remove	4-18
	Drive/Lift Mode Switch - Install/Remove	4-18
	Horn Button Switch - Install/Remove	4-18
	Key Switch - Install/Remove	4-18
	E-Stop/ShutDown Switch - Install/Remove	4-19
	Joystick Assembly - Install/Remove	4-19
4.8	PUMP-MOTOR ASSEMBLY - SERVICE PROCEDURE	4-20
	Hydraulic Pressure settings and Adjustment	4-20
	Hydraulic Pressure Gauge Connection	4-20
	After Filter Pressure Check	4-21
	Pump/Motor/Tank Installation	4-21
	General Installation and Disassembly	4-22
	Inline Hydraulic Filter Installation	4-22
	FENNER BRAND PUMP - Brush Replacement	4-22
	Motor Cap/Motor Installation	4-22
	Motor Brush Installation	4-23
	Brush Housing Final Assembly Tips	4-24
	MONARCH BRAND PUMP - Brush Replacement	4-25
	Motor Assembly - Remove/Install - Reference Marks	4-25
	Motor/Brush Cover - Remove/Install	4-25
	Brush Carrier Assembly - Remove/Install	4-26
	Brush Assembly - Remove/Install	4-26
	Tank Installation	4-27
	Filter Screen Installation	4-27
	Pump Installation	4-27
	Pressure Adjust Valve Installation	4-28
	Pressure Check Valve Installation	4-28

TABLE OF CONTENTS

4.9	OBSTRUCTION SENSOR SYSTEM - SERVICE PROCEDURE (MSP - OPTION)	4-29
	General	4-29
	Transducer Sensor Check	4-30
	OSS Component Installation	4-31

SECTION 5 - MAST COMPONENTS

5.1	MAST COMPONENTS OVERVIEW	5-1
5.2	MAST CHAINS AND SEQUENCING CABLES ADJUSTMENT	5-2
	Mast Chain/Cable Adjustment	5-2
	Sequencing Cable Adjustment	5-2
5.3	SEQUENCE CABLE REPLACEMENT KIT	5-4
	Remove Old Cable	5-4
	Replacement Cable Installation	5-4
	Clamp Installation (Drum/Socket Type)	5-4
5.4	HYDRAULIC LINE - DISCONNECT - SPECIAL TOOL	5-7
	Tool Use - In-Line Style Fittings	5-7
	Tool Use - Angled Style Fittings	5-8
5.5	HYDRAULIC LIFT CYLINDER - REMOVAL, INSPECTION AND REBUILD	5-9
	Lift Cylinder Removal	5-9
	Cylinder Disassembly	5-12
	Lift Cylinder Component Inspection	5-12
	Cylinder Assembly (See Figure 5-4.)	5-13
	Cylinder Installation	5-13
5.6	MAST ASSEMBLY INSTALLATION	5-15
	Mast Removal	5-15
	Mast Installation	5-15
5.7	MAST ASSEMBLY AND DISASSEMBLY PROCEDURES	5-16
	Mast Disassembly Procedure	5-16
	Mast Assembly - MVL/MSP	5-19
5.8	MSP - STOCKPICKER PLATFORM - INSTALLATION	5-27
5.9	MSP - STOCKPICKER PLATFORM - MID-GATE INTERLOCK INSTALLATION	5-28
5.10	MAST BEACON - INSTALLATION	5-28
5.11	GATE ALARM - INSTALLATION - OPTION (FOR SIDE ENTRY W/FOLDING MATERIAL TRAY PLATFORM ONLY)	5-29
	Switches and Wiring	5-29
5.12	MAST - 14 FT. HEIGHT LIMITING SWITCH -15MSP OPTION	5-30

SECTION 6 - TROUBLESHOOTING

6.1	GENERAL	6-1
6.2	TROUBLESHOOTING INFORMATION	6-1
6.3	HYDRAULIC CIRCUIT CHECKS	6-1
6.4	ELECTRICAL CIRCUIT CHECKS	6-1
	General	6-1
6.5	MULTIMETER BASICS	6-2
	Grounding	6-2
	Backprobing	6-2
	Min/Max	6-2
	Polarity	6-2
	Scale	6-2
	Continuity Measurement Over Long Distances	6-5
	Requirements:	6-5
	Procedure	6-5

6.6	ELECTRICAL SWITCH TESTING	6-6
	Basic Check	6-6
	Limit Switches	6-6
	Automatic Switches	6-7
	Switch Wiring - Low Side, High Side	6-7
6.7	GROUND CONTROL MODULE LCD DISPLAY	6-8
6.8	TROUBLESHOOTING TABLES INDEX	6-14
	Specifications For Various Components	6-14
	Special Pin Extractor Tools For Electrical Connectors	6-14
	Fault Code Troubleshooting Tables	6-14
	Main Power Circuit Troubleshooting	6-15
	Mast Troubleshooting	6-15
	Hydraulic Leak Troubleshooting	6-15
	Base Frame Components Troubleshooting	6-15
	Drive System Troubleshooting	6-15
6.9	SPECIFICATIONS FOR VARIOUS COMPONENTS	6-16
6.10	SPECIAL PIN EXTRACTOR TOOLS FOR ELECTRICAL CONNECTORS	6-16
6.11	FAULT CODE TROUBLESHOOTING TABLES	6-17
	Machine in Drive Speed Cut-Back (Turtle) Mode All The Time	6-17
	Obstruction Sensor System - Detection	6-18
	Battery Voltage Low - Warning Level 3 - Three (3) LED/LCDs lit	6-18
	Code 02 - Left PHP Bar - UP	6-19
	Code 03 - Right PHP Bar - UP	6-19
	Code 04 - Tilt Condition	6-20
	Code 05 - Reserved	6-20
	Code 06 - Drive Motor Brush Wear Warning Indicator	6-21
	Code 07 - Left Drive Motor - Disconnected	6-21
	Code 08 - Right Drive Motor - Disconnected	6-22
	Code 09 - Left Brake - Disconnected	6-22
	Code 10 - Right Brake - Disconnected	6-22
	Code 11 - Left Drive Motor - Short Circuit	6-23
	Code 12 - Right Drive Motor - Short Circuit	6-23
	Code 13 - Traction Module - In Fold Back	6-23
	Code 14 - Pump Motor - Disconnected	6-24
	Code 15 - Lift Down Valve - Disconnected	6-24
	Code 16 - Lift Down Valve - Short Circuit	6-25
	Code 17 - Ground Control Module - In Fold Back	6-25
	Code 18 - Alarm - Short Circuit	6-25
	Code 19 - Alarm - Disconnected	6-26
	Code 20 - Beacon - Short Circuit	6-26
	Code 21 - Beacon - Disconnected	6-27
	Code 22 - Horn - Short Circuit	6-27
	Code 23 - Horn - Disconnected	6-28
	Code 24 - Auxiliary #1 Circuit - Short Circuit	6-28
	Code 25 - Auxiliary #1 Circuit - Disconnected	6-29
	Code 26 - Auxiliary #2 - Short Circuit	6-29
	Code 27 - Auxiliary #2 - Disconnected	6-30
	Code 28 - Reserved	6-30
	Code 29 - Reserved	6-30
	Code 30 - Traction Module - No Communication with Ground Control Module	6-30
	Code 31 - Platform Control Console - No Communication with Ground Control Module	6-31
	Code 32 - Pump Motor - Over Current	6-31
	Code 33 - Both PHP Bars - UP	6-32
	Code 34 - P2-Auxiliary #1 - Inhibit	6-32
	Code 35 - P2-Auxiliary #1 - Tie Down	6-32
	Code 38 - Battery Voltage Low - Warning Level 2 - Two (2) LED/LCDs lit	6-33

TABLE OF CONTENTS

Code 39 - Battery Voltage Low - Warning Level 3 - One (1) LED/LCDs lit	6-33
Code 40 - Obstruction Sensor System - No Communication with Ground Control Module	6-34
Codes 41 thru 46 - OSS - Sensor 1 through 6 - Fault Condition	6-35
Codes (100 - 199) Ground Control Module - Fault Condition	6-36
Codes (200 - 299) Platform Control Console - Fault Condition	6-37
Codes (300 - 399) Traction Control Module - Fault Condition	6-38
6.12 MAIN POWER CIRCUIT TROUBLESHOOTING	6-39
Machine Will Not Power Up	6-39
6.13 MAST TROUBLESHOOTING	6-40
Platform Will Not Lower Manually	6-40
Platform Lift Up And Down - Jerky	6-40
Mast Noisy When Lifting And Lowering	6-41
Platform (Mast) Won't Stay Elevated	6-42
Platform (Mast) Descends Too Slowly	6-42
6.14 HYDRAULIC LEAK TROUBLESHOOTING	6-43
Miscellaneous Hydraulic Leak Troubleshooting	6-43
6.15 BASE FRAME COMPONENTS TROUBLESHOOTING	6-44
Caster Wheels Not Operating Freely	6-44
Pot Hole Protection (PHP) Bars will not Lower	6-44
6.16 DRIVE SYSTEM TROUBLESHOOTING	6-45
Won't Climb Grade	6-45
Machine Drives in Opposite Direction	6-45
Machine Won't Drive Straight	6-46
Noise From Drive Assembly	6-47

LIST OF FIGURES

FIGURE NO.	TITLE	PAGE NO.
1-1.	Torque Chart (SAE Fasteners - Sheet 1 of 7)	1-6
1-2.	Torque Chart (SAE Fasteners - Sheet 2 of 7))	1-7
1-3.	Torque Chart (SAE Fasteners - Sheet 3 of 7)	1-8
1-4.	Torque Chart (SAE Fasteners - Sheet 4 of 7)	1-9
1-5.	Torque Chart (METRIC Fasteners - Sheet 5 of 7))	1-10
1-6.	Torque Chart (METRIC Fasteners - Sheet 6 of 7)	1-11
1-7.	Torque Chart (METRIC Fasteners - Sheet 7 of 7)	1-12
3-1.	Base Components.	3-1
3-2.	Wheel Lug Nut Tightening Sequence.	3-3
4-1.	Control Components Location - MVL/MSP.	4-1
4-2.	Component Electrical Connections. (2-12V Batteries shown)	4-6
4-3.	Battery Cable to Battery Terminal Connections (4-6V)	4-7
4-4.	Ground Control Module Components.	4-8
4-5.	Platform Control Console Components.	4-16
4-6.	Hydraulic Pressure Adjustment Screw. (Machine Rear Covers Removed)	4-20
4-7.	Typical Hydraulic Pressure Gauge Installation (Hydraulic Filter Removed)	4-20
4-8.	Typical Hydraulic Pressure Gauge Installation (After Hydraulic Filter)	4-21
4-9.	Obstruction Sensor System Components (Platform Cutaway)	4-29
5-1.	Mast Components. (MVL/MSP)	5-1
5-2.	MVL/MSP - Mast Chain and Sequence Cable Adjustment Components.	5-3
5-3.	Machine Positioned for Cylinder Removal.	5-9
5-4.	Lift Cylinder Component Cross-Section (MVL/MSP)	5-13
5-5.	Mast Section - Assembly Reference.	5-16
5-6.	Mast Chain Routing Diagram. - MVL/MSP	5-18
5-7.	Mast Bottom End - Slide Pad Installation	5-19
5-8.	MSP - StockPicker Platform Installation.	5-27
6-1.	Voltage Measurement (DC)	6-3
6-2.	Resistance Measurement	6-3
6-3.	Continuity Measurement	6-4
6-4.	Current Measurement (DC)	6-4
6-5.	Component Electrical Connections.	6-9
6-6.	Overview of Electrical System Components. (MVL/MSP) (Sheet 1 of 2)	6-48
6-7.	Electrical Diagram. (MVL/MSP) (Sheet 1)	6-50
6-8.	Hydraulic Diagram. (MVL/MSP)	6-52

TABLE OF CONTENTS

LIST OF TABLES

TABLE NO.	TITLE	PAGE NO.
1-1	General Machine Specifications	1-1
1-2.	15MVL/MSP - Machine Maximum Wheel Loads (Lb.) and (PSI) - Per Wheel.	1-3
1-3.	20MVL/MSP - Machine Maximum Wheel Loads (Lb.) and (PSI) - Per Wheel.	1-3
1-4	Hydraulic Oil Operating Range	1-4
1-5	Lubrication Specifications	1-4
1-6	Cylinder Specifications	1-4
1-7	Lubrication Intervals for Various Components	1-5
2-1	Inspection and Maintenance.	2-2
2-2	MVL/MSP - Preventive Maintenance & Inspection Schedule.	2-3
2-3	Chain Stretch Tolerance	2-6
3-1	Wheel Torque Chart	3-3
3-2	Battery Low Voltage Warning Indicators.	3-20
3-3	Battery Charger Algorithm Settings.	3-22
4-1	MVL/MSP Ground Control Module - Field Programmable Settings and Factory Preset.	4-14
5-1	MVL/MSP Mast Component Features.	5-16
6-1	LCD Display - Service Fault Code Conditions	6-10
6-2	Ohm Ratings for Various Components.	6-16
6-3	Amperage Draw for Various Components	6-16
6-4	Special Pin Extractor Tools for Electrical Connectors	6-16
6-5	Machine In Drive Speed Cut-Back (Turtle) Mode All The Time	6-17
6-6	Obstruction Sensor System - Detection	6-18
6-7	Code 02 - Left PHP Bar - UP	6-19
6-8	Code 03 - Right PHP Bar - UP.	6-19
6-9	Code 04 - Tilt Condition	6-20
6-10	Code 06 - Drive Motor Brush Wear Warning Indicator.	6-21
6-11	Code 07 - Left Drive Motor - Disconnected	6-21
6-12	Code 08 - Right Drive Motor Disconnected	6-22
6-13	Code 09 - Left Brake - Disconnected	6-22
6-14	Code 10 - Right Brake - Disconnected	6-22
6-15	Code 11 - Left Drive Motor - Short Circuit.	6-23
6-16	Code 12 - Right Drive Motor - Short Circuit	6-23
6-17	Code 13 - Traction Module - In Fold Back	6-23
6-18	Code 14 - Pump Motor - Disconnected	6-24
6-19	Code 15 - Lift Down Valve - Disconnected	6-24
6-20	Code 16 - Lift Down Valve - Short Circuit	6-25
6-21	Code 17 - Ground Control Module - In Fold Back	6-25
6-22	Code 18 - Alarm - Short Circuit.	6-25
6-23	Code 19 - Alarm - Disconnected.	6-26
6-24	Code 20 - Beacon - Short Circuit	6-26
6-25	Code 21 - Beacon - Short Disconnected	6-27
6-26	Code 22 - Horn - Short Circuit	6-27
6-27	Code 23 - Horn - Disconnected	6-28
6-28	Code 24 - Auxiliary #1 Circuit - Short Circuit	6-28
6-29	Code 25 - Auxiliary #1 Circuit - Disconnected	6-29
6-30	Code 26 - Auxiliary #2 - Short Circuit.	6-29
6-31	Code 27 - Auxiliary #2 - Disconnected.	6-30
6-32	Code 30 - Traction Module - No Communication with Ground Control Module	6-30
6-33	Code 31 - Platform Control Console - No Communication with Ground Control Module.	6-31
6-34	Code 32 - Pump Motor - Over Current	6-31
6-35	Code 33 - Both PHP Bars - UP	6-32
6-36	Code 34 - P2-Auxiliary #1 - Inhibit	6-32
6-37	Code 35 - P2-Auxiliary #1 - Tie Down.	6-32
6-38	Code 40 - OSS - No Communication with Ground Control Module	6-34
6-39	Codes 41 thru 46 - OSS - Sensor 1 through 6 - Fault Condition	6-35

6-40 Codes (100 - 199) Ground Control Module - Fault Condition6-36
6-41 Code (200 - 299) Platform Control Console - Fault Condition6-37
6-42 Codes (300 - 399) Traction Control Module - Fault Condition6-38
6-43 Machine Will Not Power UP.6-39
6-44 Platform Will Not Lower Manually.6-40
6-45 Platform Lift Up and Down Jerky6-40
6-46 Mast Noisy when Lifting and Lowering.6-41
6-47 Platform (Mast) Won't Stay Elevated.6-42
6-48 Platform (Mast) Descends Too Slowly.....6-42
6-49 Hydraulic Leak Troubleshooting.....6-43
6-50 Caster Wheels Not Operating Freely.....6-44
6-51 Pot Hole Protection (PHP) Bars will not Lower.6-44
6-52 Won't Climb Grade6-45
6-53 Machine Drive in Opposite Direction6-45
6-54 Machine Won't Drive Straight.....6-46
6-55 Noise from Drive Assembly.6-47

SECTION 1. MACHINE SPECIFICATIONS

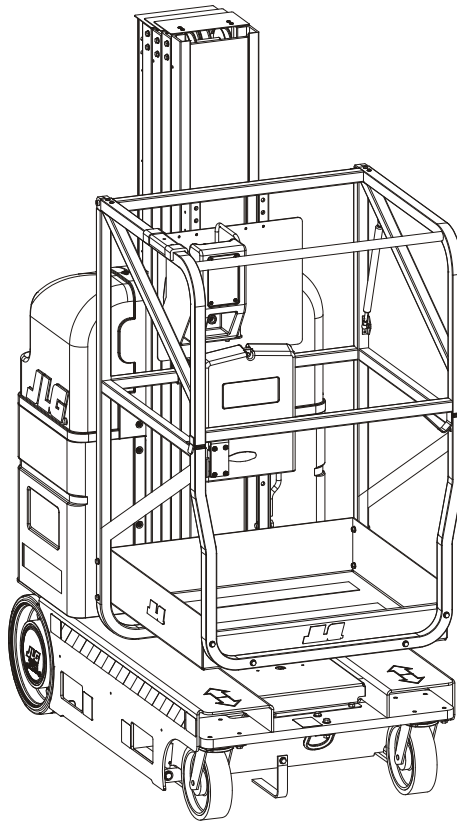

Table 1-1. General Machine Specifications

	15MVL	20MVL	15MSP	20MSP	
Maximum Occupants:	1				
Maximum Work Load (Capacity): <i>(MVL-Std. Platform / MSP - Stockpicker Platform)</i>	500 lb. (230 kg)	350 lb. (160 kg)	500 lb. (230 kg)	400 lb. (180 kg)	
Maximum Travel Grade (Gradeability): <i>(Platform STOWED ONLY)</i>	20% (11.5°)				
Maximum Travel Grade (Side Slope): <i>(Platform STOWED ONLY)</i>	5°				
Maximum Vertical Platform Height:	15 ft. 2 in. (4.69 m)	19 ft. 1 in. (5.80 m)	15 ft. 1 in. ⁽¹⁾ (4.66 m)	19 ft. 6 in. (5.96 m)	
Maximum Drive Speeds (Operator Variable):	0.5 - 3.4 mph (0.8 - 5.5 kph)				
Max. Platform Speeds (w/Max. Load):	Platform Up:	20 sec.	22.5 sec.	20 sec.	22.5 sec.
	Platform Down:	15 - 21 sec.	21 - 26 sec.	15 - 21 sec.	21 - 26 sec.
Gross Machine Weight (Platform Empty):	2,235 lb. (955 kg)	2,235 lb. (955 kg)	2,280 lb. (975 kg)	2,280 lb. (975 kg)	

NOTE: (1) Standard unless equipped with 14 ft. limiter circuit.

SECTION 1 - MACHINE SPECIFICATIONS

1.1 CAPACITIES

System Voltage

All Models – 24 Volt DC

Hydraulic System

All Models – 5 qts. U.S. (4.7 L)

Drive Motor GearBox (gear oil)

All Models – 10 oz. (296cc)

1.2 COMPONENT DATA

Hydraulic Pump/Pump Motor Assembly

Pump Motor - 24 Volt DC motor, Standard Duty

Pump Displacement –

MVL/MSP – .098 cu. in./rev. (1.6cc/rev.)

Pump Output (Max.) –

MVL/MSP - 1.20 gpm @ 2200 psi @ 23.5 volts and
105 amps @ 45 centistrokes (200 SSU)

Reservoir Capacity –

MVL/MSP - 1 Gallon (3.78 L)

Rear Wheel Drive Motors

Drive Motors - 24 Volt DC, Variable

Gear Box - 3500 in. lb. (395.5 Nm) - Continuous Output
7000 in. lb. (791 Nm) - Intermittent Output
30.68:1 Gear Ratio

Brakes - Friction Disk - Spring Applied - Electrically Released

Batteries/Battery Charger

NOTICE

JLG MACHINES EQUIPPED WITH DELTA Q BATTERY CHARGERS ARE DESIGNED FOR THE BEST PERFORMANCE WITH OEM FACTORY APPROVED BATTERIES.

APPROVED JLG REPLACEMENT BATTERIES ARE AVAILABLE THROUGH JLG'S AFTERMARKET PARTS DISTRIBUTION CENTERS OR JLG'S AFTERMARKET PROGRAMS. FOR ASSISTANCE WITH PROPER BATTERY REPLACEMENT, PLEASE CONTACT YOUR LOCAL JLG SUPPORT OFFICE.

BATTERIES APPROVED BY JLG HAVE BEEN TESTED FOR COMPATIBILITY WITH THE ALGORITHM PROGRAMMING OF THE DELTA Q BATTERY CHARGER TO OPTIMIZE BATTERY LIFE AND MACHINE CYCLE TIMES. THE USE OF NON APPROVED BATTERIES IN YOUR JLG EQUIPMENT MAY RESULT IN PERFORMANCE ISSUES OR BATTERY CHARGER FAULT CODES. JLG ASSUMES NO RESPONSIBILITY FOR SERVICE OR PERFORMANCE ISSUES ARISING FROM THE USE OF NON APPROVED BATTERIES.

Batteries (2) (STD) - AGM - 12 Volt/100 Amp Hour - (@ 20 Hr. rate)
- Sealed/Maintenance Free
- Weight – 71-75 lb. (34 Kg) - Per Battery

Batteries (4) (OPTION) - AGM - 6 Volt/220 Amp Hour - (@ 20 Hr. rate)
- Sealed/Maintenance Free
- Weight – 66 lb. (30 Kg) - Per Battery

Battery Charger –

Microprocessor Controlled/SCR Circuit Monitor
120/240 Volt A.C. Selectable 50/60 Hz input
24 volt, 20 amp output - with 2 amp finish
Reset Circuit Breaker
Automatic Charge Circuit
Plug Interlock Circuit

NOTE: The batteries on MVL/MSP machines require approximately five (5) hours to fully charge when drained to LOW BATTERY VOLTAGE warning on the Ground Control Module LCD display.

1.3 PERFORMANCE DATA

Platform Capacities

GullWing-Front - **15MVL** - 500 lb. (230kg)
20MVL - 350 lb. (160kg)

SlideBar-Front - **15MVL** - 500 lb. (230kg)
20MVL - 350 lb. (160kg)

StockPicker - **15MSP** - 500 lb. (230kg)
20MSP - 400 lb. (180kg)

GullWing-Extendible - **15MVL** - 500 lb. (230kg)
20MVL - 350 lb. (160kg)

SideEntry/w Folding Material Tray -

SPEC	Model ⁽¹⁾	Platform Capacity	Tray Capacity	Combined Capacity
ANSI/CSA	15MSP	300 lb. (136 kg)	150 lb. (70 kg)	450 lb. (206 kg)
	20MSP	300 lb. (136 kg)	150 lb. (70 kg)	450 lb. (206 kg)
CE	20MVL	250 lb. (115kg)	100 lb. (45 kg)	350 lb. (160 kg)
AUS	15MVL	350 lb. (160 kg)	150 lb. (70 kg)	500 lb. (230 kg)
	20MVL	250 lb. (115kg)	100 lb. (45 kg)	350 lb. (160 kg)

(1) This platform is only available on models shown.

NOTE: Distribute weight evenly in platform when loading. Reference the capacity decal on the machines' decal billboard mounted on mast.

SECTION 1 - MACHINE SPECIFICATIONS

Platform Size

- Oversized Standard** - 26 in.- W x 28 in.- L (66cm x 71cm)
- Stockpicker** - 28 in.- W x 48 in.- L (71cm x 122cm)
- Extendible** - 26 in.- W x 49 in.- L (66cm x 124cm)
- Plat. w/Mat'l Tray** - 27 in.- W x 23 in.- L (68cm x 58cm)
- Plat. w/Folding Tray** - 26 in.- W x 30 in.- L (66cm x 76cm)

Machine Ground Clearance

- PHP Retracted - 2 in. (5.1cm)
- PHP Extended - 0.75 in. (1.9cm)

Base Footprint

MVL/MSP - 29.25 in.- W x 52 in.- L (74cm) x (132cm)

Machine Height (platform stowed)

MVL/MSP - 78 in. (198cm) height

Table 1-2. 15MVL/MSP - Machine Maximum Wheel Loads (Lb.) and (PSI) - Per Wheel.

Platform Type (Loaded to Max. Capacity)	15MVL				15MSP			
	Average Maximum				Average Maximum			
	Wheel Load Per Wheel (Lb.)		(PSI) Per Wheel		Wheel Load Per Wheel (Lb.)		(PSI) Per Wheel	
	Rear	Front	Rear	Front	Rear	Front	Rear	Front
22x25 SB	865	490	138	252				
28x26 GW	845	550	128	265				
26x50 GW	860	515	115	321	860	515	115	321
28x48 SP					755	615	117	306
w/Folding Tray					810	565	125	313

NOTE: Platform Types: SB - with Sliding Bar Gate GW - with Gull Wing Gate SP - Stock Picker Platform

Table 1-3. 20MVL/MSP - Machine Maximum Wheel Loads (Lb.) and (PSI) - Per Wheel.

Platform Type (Loaded to Max. Capacity)	20MVL				20MSP			
	Average Maximum				Average Maximum			
	Wheel Load Per Wheel (Lb.)		(PSI) Per Wheel		Wheel Load Per Wheel (Lb.)		(PSI) Per Wheel	
	Rear	Front	Rear	Front	Rear	Front	Rear	Front
22x25 SB	855	450	132	250				
28x26 GW	835	460	121	261				
26x50 GW	850	480	131	277	850	480	131	259
28x48 SP					815	560	120	320
w/Folding Tray					810	565	125	313

NOTE: Platform Types: SB - with Sliding Bar Gate GW - with Gull Wing Gate SP - Stock Picker Platform

1.4 LUBRICATION

NOTE: Also see Lubrication Interval Chart - Table 1-7, Lubrication Intervals for Various Components in this section of the manual.

Hydraulic Oil

Hydraulic oils must have anti-wear qualities at least to API Service Classification GL-3, and sufficient chemical stability for mobile hydraulic system service. JLG Industries, recommends Mobilfluid 424 hydraulic oil, which has an SAE viscosity of 10W-30 and a viscosity index of 152.

For cold weather applications, i.e. when temperatures remain consistently below +20°F (-7°C) JLG recommends using Mobil DTE 13 hydraulic oil.

Aside from JLG recommendations, it is not advisable to mix oils of different brands or types, as they may not contain the same required additives or be of comparable viscosities. If use of hydraulic oil other than Mobilfluid 424 is desired, contact JLG Industries for proper recommendations.

Table 1-4. Hydraulic Oil Operating Range

HYDRAULIC SYSTEM OPERATING TEMPERATURE RANGE	SAE VISCOSITY GRADE
+0° F to +180° F (-18° C to +83° C)	10W
+0° F to +210° F (-18° C to +99° C)	10W-20, 10W-30
+50° F to +210° F (+10° C to +99° C)	20W-20

Lubrication Specifications

Table 1-5. Lubrication Specifications

KEY	SPECIFICATIONS
MPG -	Multipurpose Grease having a minimum dripping point of 350° F. Excellent water resistance and adhesive qualities, and being of extreme pressure type. (Timken OK 40 pounds minimum.)
EPGL -	Extreme Pressure Gear Lube (oil) meeting API service classification GL-5 or MIL-Spec MIL-L-2105.
HO -	Hydraulic Oil. ISO-Vg grade 32, 46.
CL -	Chain Lube. Use a good quality chain lubricant.

1.5 CYLINDER SPECIFICATIONS

NOTE: All dimensions are given in inches (in), with the metric equivalent, centimeters (cm), given in parentheses.

Table 1-6. Cylinder Specifications

DESCRIPTION	BORE in./(cm)	STROKE in./(cm)	ROD DIA. in./(cm)
15MVL/15MSP - Lift Cylinder	1.63 (4.10)	41.50 (105.4)	1.375 (3.49)
20MVL/20MSP - Lift Cylinder	1.63 (4.10)	54.0 (137.1)	1.375 (3.49)

1.6 SERIAL NUMBER LOCATIONS

For machine identification, a serial number plate is affixed to the machine. The plate is located on the back of the mast, just above the mast support column.

1.7 TORQUE REQUIREMENTS

When maintenance becomes necessary or a fastener has loosened, refer to the applicable Torque Charts in this section of the manual, to determine proper torque values for different size fasteners.

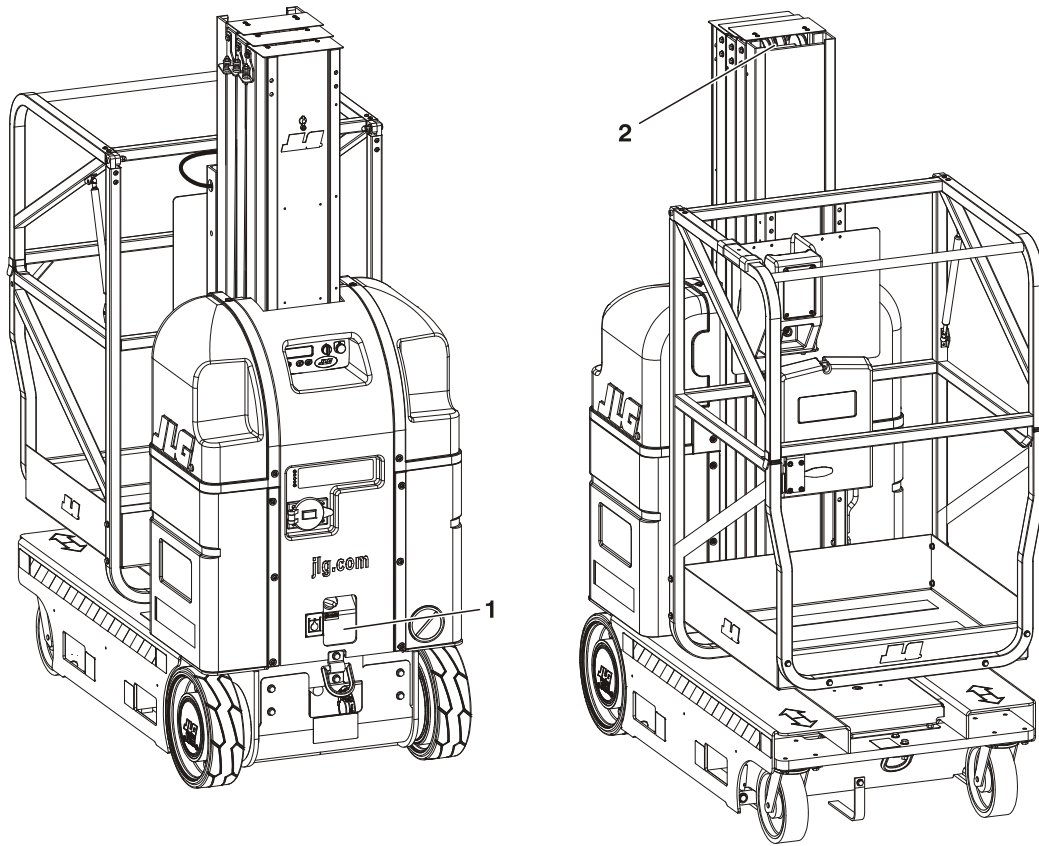

Table 1-7. Lubrication Intervals for Various Components

ITEM	COMPONENT	NO/TYPE (a) LUBE POINTS	LUBE/METHOD	INTERVAL (b)				COMMENTS
				3 MONTHS	6 MONTHS	1 YEAR	2 YEARS	
1	Hydraulic Oil	Fill To Line on Reservoir 5 Qt. Reservoir	HO - Check Hyd. Oil Level HO - Change Hyd. Oil				✓	Check fluid level every day. (c) Change hydraulic oil every 2 years.
2	Mast Chains	2 - Per Section	Chain Lube - Brush or Spray		✓			Inspect, lubricate if dry or rusting.
Key to Lubricants: MPG - Multipurpose Grease HO - Hydraulic Oil - ISO-Vg grade 32, 46. GEAR OIL - Good Quality Worm Gear Oil - SAE 90 - AGMA#5 - EP Compounded CL - Chain Lube. Use a good quality chain lubricant								
Notes: (a) Be certain to lubricate like items on each side of the machine. (b) Recommended lubricating intervals are based on normal use. If machine is subjected to severe operating conditions, such as a high number of cycles, location, corrosive/dirty environment, etc., user must adjust lubricating requirements accordingly. (c) Prior to checking hydraulic oil level, operate machine through one complete cycle of lift function (full up and down). Failure to do so will result in incorrect oil level reading on the hydraulic reservoir.								

SECTION 1 - MACHINE SPECIFICATIONS

Values for Zinc Yellow Chromate Fasteners (Ref 4150707)
SAE GRADE 5 BOLTS & GRADE 2 NUTS

Size	TPI	Bolt Dia	Tensile Stress Area	Clamp Load	Torque (Dry)		Torque Lubricated		Torque (Loctite® 242™ or 271™ OR Vibra-TITE™ 111 or 140)		Torque (Loctite® 262™ or Vibra-TITE™ 131)	
					IN-LB	[N.m]	IN-LB	[N.m]	IN-LB	[N.m]	IN-LB	[N.m]
		In	Sq In	LB								
4	40	0.1120	0.00604	380	8	0.9	6	0.7				
	48	0.1120	0.00661	420	9	1.0	7	0.8				
6	32	0.1380	0.00909	580	16	1.8	12	1.4				
	40	0.1380	0.01015	610	18	2.0	13	1.5				
8	32	0.1640	0.01400	900	30	3.4	22	2.5				
	36	0.1640	0.01474	940	31	3.5	23	2.6				
10	24	0.1900	0.01750	1120	43	4.8	32	3.5				
	32	0.1900	0.02000	1285	49	5.5	36	4				
1/4	20	0.2500	0.0318	2020	96	10.8	75	9	105	12		
	28	0.2500	0.0364	2320	120	13.5	86	10	135	15		
		In	Sq In	LB	FT-LB	[N.m]	FT-LB	[N.m]	FT-LB	[N.m]	FT-LB	[N.m]
5/16	18	0.3125	0.0524	3340	17	23	13	18	19	26	16	22
	24	0.3125	0.0580	3700	19	26	14	19	21	29	17	23
3/8	16	0.3750	0.0775	4940	30	41	23	31	35	48	28	38
	24	0.3750	0.0878	5600	35	47	25	34	40	54	32	43
7/16	14	0.4375	0.1063	6800	50	68	35	47	55	75	45	61
	20	0.4375	0.1187	7550	55	75	40	54	60	82	50	68
1/2	13	0.5000	0.1419	9050	75	102	55	75	85	116	68	92
	20	0.5000	0.1599	10700	90	122	65	88	100	136	80	108
9/16	12	0.5625	0.1820	11600	110	149	80	108	120	163	98	133
	18	0.5625	0.2030	12950	120	163	90	122	135	184	109	148
5/8	11	0.6250	0.2260	14400	150	203	110	149	165	224	135	183
	18	0.6250	0.2560	16300	170	230	130	176	190	258	153	207
3/4	10	0.7500	0.3340	21300	260	353	200	271	285	388	240	325
	16	0.7500	0.3730	23800	300	407	220	298	330	449	268	363
7/8	9	0.8750	0.4620	29400	430	583	320	434	475	646	386	523
	14	0.8750	0.5090	32400	470	637	350	475	520	707	425	576
1	8	1.0000	0.6060	38600	640	868	480	651	675	918	579	785
	12	1.0000	0.6630	42200	700	949	530	719	735	1000	633	858
1 1/8	7	1.1250	0.7630	42300	800	1085	600	813	840	1142	714	968
	12	1.1250	0.8560	47500	880	1193	660	895	925	1258	802	1087
1 1/4	7	1.2500	0.9690	53800	1120	1518	840	1139	1175	1598	1009	1368
	12	1.2500	1.0730	59600	1240	1681	920	1247	1300	1768	1118	1516
1 3/8	6	1.3750	1.1550	64100	1460	1979	1100	1491	1525	2074	1322	1792
	12	1.3750	1.3150	73000	1680	2278	1260	1708	1750	2380	1506	2042
1 1/2	6	1.5000	1.4050	78000	1940	2630	1460	1979	2025	2754	1755	2379
	12	1.5000	1.5800	87700	2200	2983	1640	2224	2300	3128	1974	2676

NO. 5000059 REV. J

- NOTES: 1. THESE TORQUE VALUES DO NOT APPLY TO CADMIUM PLATED FASTENERS
 2. ALL TORQUE VALUES ARE STATIC TORQUE MEASURED PER STANDARD AUDIT METHODS TOLERANCE = ±10%
 3. * ASSEMBLY USES HARDENED WASHER

REFERENCE JLG ANEROBIC THREAD LOCKING COMPOUND				
JLG P/N	Loctite® P/N		ND Industries P/N	Description
0100011	242™		Vibra-TITE™ 121	Medium Strength (Blue)
0100019	271™		Vibra-TITE™ 140	High Strength (Red)
0100071	262™		Vibra-TITE™ 131	Medium - High Strength (Red)

Figure 1-1. Torque Chart (SAE Fasteners - Sheet 1 of 7)

SECTION 1 - MACHINE SPECIFICATIONS

Values for Zinc Yellow Chromate Fasteners (Ref 4150707)
SAE GRADE 8 (HEX HD) BOLTS & GRADE 8 NUTS*

Size	TPI	Bolt Dia	Tensile Stress Area	Clamp Load	Torque (Dry or Loctite® 263) K= 0.20		Torque (Loctite® 242™ or 271™ OR Vibra-TITE™ 111 or 140) K=0.18		Torque (Loctite® 262™ or Vibra-TITE™ 131) K=0.15	
					IN-LB	[N.m]	IN-LB	[N.m]	IN-LB	[N.m]
		In	Sq In	LB	FT-LB	[N.m]	FT-LB	[N.m]	FT-LB	[N.m]
4	40	0.1120	0.00604							
	48	0.1120	0.00661							
6	32	0.1380	0.00909							
	40	0.1380	0.01015							
8	32	0.1640	0.01400							
	36	0.1640	0.01474	1320	43	5				
10	24	0.1900	0.01750	1580	60	7				
	32	0.1900	0.02000	1800	68	8				
1/4	20	0.2500	0.0318	2860	143	16	129	15		
	28	0.2500	0.0364	3280	164	19	148	17		
		In	Sq In	LB	FT-LB	[N.m]	FT-LB	[N.m]	FT-LB	[N.m]
5/16	18	0.3125	0.0524	4720	25	35	20	25	20	25
	24	0.3125	0.0580	5220	25	35	25	35	20	25
3/8	16	0.3750	0.0775	7000	45	60	40	55	35	50
	24	0.3750	0.0878	7900	50	70	45	60	35	50
7/16	14	0.4375	0.1063	9550	70	95	65	90	50	70
	20	0.4375	0.1187	10700	80	110	70	95	60	80
1/2	13	0.5000	0.1419	12750	105	145	95	130	80	110
	20	0.5000	0.1599	14400	120	165	110	150	90	120
9/16	12	0.5625	0.1820	16400	155	210	140	190	115	155
	18	0.5625	0.2030	18250	170	230	155	210	130	175
5/8	11	0.6250	0.2260	20350	210	285	190	260	160	220
	18	0.6250	0.2560	23000	240	325	215	290	180	245
3/4	10	0.7500	0.3340	30100	375	510	340	460	280	380
	16	0.7500	0.3730	33600	420	570	380	515	315	430
7/8	9	0.8750	0.4620	41600	605	825	545	740	455	620
	14	0.8750	0.5090	45800	670	910	600	815	500	680
1	8	1.0000	0.6060	51500	860	1170	770	1045	645	875
	12	1.0000	0.6630	59700	995	1355	895	1215	745	1015
1 1/8	7	1.1250	0.7630	68700	1290	1755	1160	1580	965	1310
	12	1.1250	0.8560	77000	1445	1965	1300	1770	1085	1475
1 1/4	7	1.2500	0.9690	87200	1815	2470	1635	2225	1365	1855
	12	1.2500	1.0730	96600	2015	2740	1810	2460	1510	2055
1 3/8	6	1.3750	1.1550	104000	2385	3245	2145	2915	1785	2430
	12	1.3750	1.3150	118100	2705	3680	2435	3310	2030	2760
1 1/2	6	1.5000	1.4050	126500	3165	4305	2845	3870	2370	3225
	12	1.5000	1.5800	142200	3555	4835	3200	4350	2665	3625

- NO. 5000059 REV. J
- NOTES: 1. THESE TORQUE VALUES DO NOT APPLY TO CADMIUM PLATED FASTENERS
 2. ALL TORQUE VALUES ARE STATIC TORQUE MEASURED PER STANDARD AUDIT METHODS TOLERANCE = ±10%
 3. * ASSEMBLY USES HARDENED WASHER

Figure 1-2. Torque Chart (SAE Fasteners - Sheet 2 of 7)

SECTION 1 - MACHINE SPECIFICATIONS

SOCKET HEAD CAP SCREWS										
Magni Coating (Ref 4150701)*										
Size	TPI	Bolt Dia	Tensile Stress Area	Clamp Load See Note 4	Torque (Dry) K = .17		Torque (Loctite® 242™ or 271™ OR Vibra-TITE™ 111 or 140 OR Precoat 85® K=0.16		Torque (Loctite® 262™ or Vibra-TITE™ 131) K=0.15	
					IN-LB	[N.m]	IN-LB	[N.m]	IN-LB	[N.m]
		In	Sq In	LB						
4	40	0.1120	0.00604							
	48	0.1120	0.00661							
6	32	0.1380	0.00909							
	40	0.1380	0.01015							
8	32	0.1640	0.01400							
	36	0.1640	0.01474							
10	24	0.1900	0.01750							
	32	0.1900	0.02000							
1/4	20	0.2500	0.0318	2860	122	14	114	13		
	28	0.2500	0.0364	3280	139	16	131	15		
		In	Sq In	LB	FT-LB	[N.m]	FT-LB	[N.m]	FT-LB	[N.m]
5/16	18	0.3125	0.0524	4720	20	25	20	25	20	25
	24	0.3125	0.0580	5220	25	35	20	25	20	25
3/8	16	0.3750	0.0775	7000	35	50	35	50	35	50
	24	0.3750	0.0878	7900	40	55	40	55	35	50
7/16	14	0.4375	0.1063	9550	60	80	55	75	50	70
	20	0.4375	0.1187	10700	65	90	60	80	60	80
1/2	13	0.5000	0.1419	12750	90	120	85	115	80	110
	20	0.5000	0.1599	14400	100	135	95	130	90	120
9/16	12	0.5625	0.1820	16400	130	175	125	170	115	155
	18	0.5625	0.2030	18250	145	195	135	185	130	175
5/8	11	0.6250	0.2260	20350	180	245	170	230	160	220
	18	0.6250	0.2560	23000	205	280	190	260	180	245
3/4	10	0.7500	0.3340	30100	320	435	300	410	280	380
	16	0.7500	0.3730	33600	355	485	335	455	315	430
7/8	9	0.8750	0.4620	41600	515	700	485	660	455	620
	14	0.8750	0.5090	45800	570	775	535	730	500	680
1	8	1.0000	0.6060	51500	730	995	685	930	645	875
	12	1.0000	0.6630	59700	845	1150	795	1080	745	1015
1 1/8	7	1.1250	0.7630	68700	1095	1490	1030	1400	965	1310
	12	1.1250	0.8560	77000	1225	1665	1155	1570	1085	1475
1 1/4	7	1.2500	0.9690	87200	1545	2100	1455	1980	1365	1855
	12	1.2500	1.0730	96600	1710	2325	1610	2190	1510	2055
1 3/8	6	1.3750	1.1550	104000	2025	2755	1905	2590	1785	2430
	12	1.3750	1.3150	118100	2300	3130	2165	2945	2030	2760
1 1/2	6	1.5000	1.4050	126500	2690	3660	2530	3440	2370	3225
	12	1.5000	1.5800	142200	3020	4105	2845	3870	2665	3625

NO. 500059 REV. J

- NOTES: 1. THESE TORQUE VALUES DO NOT APPLY TO CADMIUM PLATED FASTENERS
 2. ALL TORQUE VALUES ARE STATIC TORQUE MEASURED PER STANDARD AUDIT METHODS TOLERANCE = ±10%
 *3. ASSEMBLY USES HARDENED WASHER OR FASTENER IS PLACED AGAINST PLATED STEEL OR RAW ALUMINUM
 4. CLAMP LOAD LISTED FOR SHCS IS SAME AS GRADE 8 OR CLASS 10.9 AND DOES NOT REPRESENT FULL STRENGTH CAPABILITY OF SHCS. IF HIGHER LOAD IS REQUIRED, ADDITIONAL TESTING IS REQUIRED.

Figure 1-3. Torque Chart (SAE Fasteners - Sheet 3 of 7)

SOCKET HEAD CAP SCREWS										
Zinc Yellow Chromate Fasteners (Ref 4150707)*										
Size	TPI	Bolt Dia	Tensile Stress Area	Clamp Load See Note 4	Torque (Dry) K = .20		Torque (Loctite® 242™ or 271™ OR Vibra-TITE™ 111 or 140 OR Precoat 85® K=0.18		Torque (Loctite® 262™ or Vibra-TITE™ 131) K=0.15	
					IN-LB	[N.m]	IN-LB	[N.m]	IN-LB	[N.m]
		In	Sq In	LB						
4	40	0.1120	0.00604							
	48	0.1120	0.00661							
6	32	0.1380	0.00909							
	40	0.1380	0.01015							
8	32	0.1640	0.01400							
	36	0.1640	0.01474							
10	24	0.1900	0.01750							
	32	0.1900	0.02000							
1/4	20	0.2500	0.0318	2860	143	16	129	15		
	28	0.2500	0.0364	3280	164	19	148	17		
		In	Sq In	LB	FT-LB	[N.m]	FT-LB	[N.m]	FT-LB	[N.m]
5/16	18	0.3125	0.0524	4720	25	35	20	25	20	25
	24	0.3125	0.0580	5220	25	35	25	35	20	25
3/8	16	0.3750	0.0775	7000	45	60	40	55	35	50
	24	0.3750	0.0878	7900	50	70	45	60	35	50
7/16	14	0.4375	0.1063	9550	70	95	65	90	50	70
	20	0.4375	0.1187	10700	80	110	70	95	60	80
1/2	13	0.5000	0.1419	12750	105	145	95	130	80	110
	20	0.5000	0.1599	14400	120	165	110	150	90	120
9/16	12	0.5625	0.1820	16400	155	210	140	190	115	155
	18	0.5625	0.2030	18250	170	230	155	210	130	175
5/8	11	0.6250	0.2260	20350	210	285	190	260	160	220
	18	0.6250	0.2560	23000	240	325	215	290	180	245
3/4	10	0.7500	0.3340	30100	375	510	340	460	280	380
	16	0.7500	0.3730	33600	420	570	380	515	315	430
7/8	9	0.8750	0.4620	41600	605	825	545	740	455	620
	14	0.8750	0.5090	45800	670	910	600	815	500	680
1	8	1.0000	0.6060	51500	860	1170	775	1055	645	875
	12	1.0000	0.6630	59700	995	1355	895	1215	745	1015
1 1/8	7	1.1250	0.7630	68700	1290	1755	1160	1580	965	1310
	12	1.1250	0.8560	77000	1445	1965	1300	1770	1085	1475
1 1/4	7	1.2500	0.9690	87200	1815	2470	1635	2225	1365	1855
	12	1.2500	1.0730	96600	2015	2740	1810	2460	1510	2055
1 3/8	6	1.3750	1.1550	104000	2385	3245	2145	2915	1785	2430
	12	1.3750	1.3150	118100	2705	3680	2435	3310	2030	2760
1 1/2	6	1.5000	1.4050	126500	3165	4305	2845	3870	2370	3225
	12	1.5000	1.5800	142200	3555	4835	3200	4350	2665	3625

NO. 500059 REV. J

- NOTES: 1. THESE TORQUE VALUES DO NOT APPLY TO CADMIUM PLATED FASTENERS
 2. ALL TORQUE VALUES ARE STATIC TORQUE MEASURED PER STANDARD AUDIT METHODS TOLERANCE = ±10%
 *3. ASSEMBLY USES HARDENED WASHER OR FASTENER IS PLACED AGAINST PLATED STEEL OR RAW ALUMINUM
 4. CLAMP LOAD LISTED FOR SHCS IS SAME AS GRADE 8 OR CLASS 10.9 AND DOES NOT REPRESENT FULL STRENGTH CAPABILITY OF SHCS. IF HIGHER LOAD IS REQUIRED, ADDITIONAL TESTING IS REQUIRED.

Figure 1-4. Torque Chart (SAE Fasteners - Sheet 4 of 7)

SECTION 1 - MACHINE SPECIFICATIONS

Values for Zinc Yellow Chromate Fasteners (Ref 4150707)							
CLASS 8.8 METRIC BOLTS CLASS 8 METRIC NUTS							
Size	PITCH	Tensile Stress Area	Clamp Load	Torque (Dry or Loctite® 263™)	Torque (Lub)	Torque (Loctite® 262™ OR Vibra-TITE™ 131)	Torque (Loctite® 242™ or 271™ OR Vibra-TITE™ 111 or 140)
		Sq mm	KN	[N.m]	[N.m]	[N.m]	[N.m]
3	0.5	5.03	2.19	1.3	1.0	1.2	1.4
3.5	0.6	6.78	2.95	2.1	1.6	1.9	2.3
4	0.7	8.78	3.82	3.1	2.3	2.8	3.4
5	0.8	14.20	6.18	6.2	4.6	5.6	6.8
6	1	20.10	8.74	11	7.9	9.4	12
7	1	28.90	12.6	18	13	16	19
8	1.25	36.60	15.9	26	19	23	28
10	1.5	58.00	25.2	50	38	45	55
12	1.75	84.30	36.7	88	66	79	97
14	2	115	50.0	140	105	126	154
16	2	157	68.3	219	164	197	241
18	2.5	192	83.5	301	226	271	331
20	2.5	245	106.5	426	320	383	469
22	2.5	303	132.0	581	436	523	639
24	3	353	153.5	737	553	663	811
27	3	459	199.5	1080	810	970	1130
30	3.5	561	244.0	1460	1100	1320	1530
33	3.5	694	302.0	1990	1490	1790	2090
36	4	817	355.5	2560	1920	2300	2690
42	4.5	1120	487.0	4090	3070	3680	4290

NO. 5000059 REV. J

- NOTES: 1. THESE TORQUE VALUES DO NOT APPLY TO CADMIUM PLATED FASTENERS
 2. ALL TORQUE VALUES ARE STATIC TORQUE MEASURED PER STANDARD AUDIT METHODS TOLERANCE = ±10%
 *3. ASSEMBLY USES HARDENED WASHER OR FASTENER IS PLACED AGAINST PLATED STEEL OR RAW ALUMINUM
 4. CLAMP LOAD LISTED FOR SHCS IS SAME AS GRADE 8 OR CLASS 10.9 AND DOES NOT REPRESENT FULL STRENGTH CAPABILITY OF SHCS. IF HIGHER LOAD IS REQUIRED, ADDITIONAL TESTING IS REQUIRED.

Figure 1-5. Torque Chart (METRIC Fasteners - Sheet 5 of 7)

SECTION 1 - MACHINE SPECIFICATIONS

Values for Zinc Yellow Chromate Fasteners (Ref 4150707)						
CLASS 10.9 METRIC BOLTS CLASS 10 METRIC NUTS CLASS 12.9 SOCKET HEAD CAP SCREWS M3 - M5*						
Size	PITCH	Tensile Stress Area	Clamp Load	Torque (Dry or Loctite® 263™) K = 0.20	Torque (Lub OR Loctite® 242™ or 271™ OR Vibra-TITE™ 111 or 140) K= 0.18	Torque (Loctite® 262™ OR Vibra-TITE™ 131) K=0.15
		Sq mm	KN	[N.m]	[N.m]	[N.m]
3	0.5	5.03	3.13			
3.5	0.6	6.78	4.22			
4	0.7	8.78	5.47			
5	0.8	14.20	8.85			
6	1	20.10	12.5			
7	1	28.90	18.0	25.2	22.7	18.9
8	1.25	36.60	22.8	36.5	32.8	27.4
10	1.5	58.00	36.1	70	65	55
12	1.75	84.30	52.5	125	115	95
14	2	115	71.6	200	180	150
16	2	157	97.8	315	280	235
18	2.5	192	119.5	430	385	325
20	2.5	245	152.5	610	550	460
22	2.5	303	189.0	830	750	625
24	3	353	222.0	1065	960	800
27	3	459	286.0	1545	1390	1160
30	3.5	561	349.5	2095	1885	1575
33	3.5	694	432.5	2855	2570	2140
36	4	817	509.0	3665	3300	2750
42	4.5	1120	698.0	5865	5275	4395

NO. 500059 REV. J

- NOTES: 1. THESE TORQUE VALUES DO NOT APPLY TO CADMIUM PLATED FASTENERS
 2. ALL TORQUE VALUES ARE STATIC TORQUE MEASURED PER STANDARD AUDIT METHODS TOLERANCE = ±10%
 *3. ASSEMBLY USES HARDENED WASHER OR FASTENER IS PLACED AGAINST PLATED STEEL OR RAW ALUMINUM
 4. CLAMP LOAD LISTED FOR SHCS IS SAME AS GRADE 8 OR CLASS 10.9 AND DOES NOT REPRESENT FULL STRENGTH CAPABILITY OF SHCS. IF HIGHER LOAD IS REQUIRED, ADDITIONAL TESTING IS REQUIRED.

Figure 1-6. Torque Chart (METRIC Fasteners - Sheet 6 of 7)

SECTION 1 - MACHINE SPECIFICATIONS

Magni Coating (Ref 4150701)*						
CLASS 12.9 SOCKET HEAD CAP SCREWS M6 AND ABOVE*						
Size	PITCH	Tensile Stress Area	Clamp Load See Note 4	Torque (Dry or Loctite® 263™) K = .17	Torque (Lub OR Loctite® 242™ or 271™ OR Vibra-TITE™ 111 or 140) K = .16	Torque (Loctite® 262™ OR Vibra-TITE™ 131) K = .15
		Sq mm	kN	[N.m]	[N.m]	[N.m]
3	0.5	5.03				
3.5	0.6	6.78				
4	0.7	8.78				
5	0.8	14.20				
6	1	20.10	12.5	13	12	11
7	1	28.90	18.0	21	20	19
8	1.25	36.60	22.8	31	29	27
10	1.5	58.00	36.1	61	58	54
12	1.75	84.30	52.5	105	100	95
14	2	115	71.6	170	160	150
16	2	157	97.8	265	250	235
18	2.5	192	119.5	365	345	325
20	2.5	245	152.5	520	490	460
22	2.5	303	189.0	705	665	625
24	3	353	220.0	900	845	790
27	3	459	286.0	1315	1235	1160
30	3.5	561	349.5	1780	1680	1575
33	3.5	694	432.5	2425	2285	2140
36	4	817	509.0	3115	2930	2750
42	4.5	1120	698.0	4985	4690	4395

NO. 500059 REV. J

- NOTES: 1. THESE TORQUE VALUES DO NOT APPLY TO CADMIUM PLATED FASTENERS
 2. ALL TORQUE VALUES ARE STATIC TORQUE MEASURED PER STANDARD AUDIT METHODS TOLERANCE = ±10%
 *3. ASSEMBLY USES HARDENED WASHER OR FASTENER IS PLACED AGAINST PLATED STEEL OR RAW ALUMINUM
 4. CLAMP LOAD LISTED FOR SHCS IS SAME AS GRADE 8 OR CLASS 10.9 AND DOES NOT REPRESENT FULL STRENGTH CAPABILITY OF SHCS. IF HIGHER LOAD IS REQUIRED, ADDITIONAL TESTING IS REQUIRED.

Figure 1-7. Torque Chart (METRIC Fasteners - Sheet 7 of 7)

SECTION 2. GENERAL

2.1 MACHINE PREPARATION, INSPECTION, AND MAINTENANCE

General

This section provides the necessary information needed by those personnel that are responsible to place the machine in operation readiness and maintain its safe operating condition. For maximum service life and safe operation, ensure that all the necessary inspections and maintenance have been completed before placing the machine into service.

Preparation, Inspection, and Maintenance

It is important to establish and conform to a comprehensive inspection and preventive maintenance program. The following table outlines the periodic machine inspections and maintenance recommended by JLG Industries, Inc. Consult your national, regional, or local regulations for further requirements for aerial work platforms. The frequency of inspections and maintenance must be increased as environment, severity and frequency of usage requires.

Pre-Start Inspection

It is the User's or Operator's primary responsibility to perform a Pre-Start Inspection of the machine prior to use daily or at each change of operator. Reference the Operator's and Safety Manual for completion procedures for the Pre-Start Inspection. The Operator and Safety Manual must be read in its entirety and understood prior to performing the Pre-Start Inspection.

Pre-Delivery Inspection and Frequent Inspection

The Pre-Delivery Inspection and Frequent Inspection shall be performed by a qualified JLG equipment mechanic. JLG Industries, Inc. recognizes a qualified JLG equipment mechanic as a person who, by possession of a recognized degree, certificate, extensive knowledge, training, or experience, has successfully demonstrated the ability and proficiency to service, repair, and maintain the subject JLG product model.

The Pre-Delivery Inspection and Frequent Inspection procedures are performed in the same manner, but at different times. The Pre-Delivery Inspection shall be performed prior to each sale, lease, or rental delivery. The Frequent Inspection shall be accomplished for each machine in service for 3 months; out of service for a period of more than 3 months; or when purchased used. The frequency of this inspection must be increased as environment, severity and frequency of usage requires.

Reference the JLG Pre-Delivery and Frequent Inspection Form and the Inspection and Preventative Maintenance Schedule for items requiring inspection during the performance of these inspections. Reference the appropriate areas of this manual for servicing and maintenance procedures.

Annual Machine Inspection

The Annual Machine Inspection must be performed by a qualified JLG equipment mechanic on an annual basis, no later than thirteen (13) months from the date of the prior Annual Machine Inspection. JLG Industries, Inc. recognizes a qualified JLG equipment mechanic as a person who has successfully completed the JLG Service Training School for the subject JLG product model. Reference the machine Service and Maintenance Manual and appropriate JLG inspection form for performance of this inspection.

Reference the JLG Annual Machine Inspection Form and the Inspection and Preventative Maintenance Schedule for items requiring inspection during the performance of this inspection. Reference the appropriate areas of this manual for servicing and maintenance procedures.

For the purpose of receiving safety-related bulletins, it is important that JLG Industries, Inc. has updated ownership information for each machine. When performing each Annual Machine Inspection, notify JLG Industries, Inc. of the current machine ownership.

Preventative Maintenance

In conjunction with the specified inspections, maintenance shall be performed by a qualified JLG equipment mechanic. JLG Industries, Inc. recognizes a qualified JLG equipment mechanic as a person who, by possession of a recognized degree, certificate, extensive knowledge, training, or experience, has successfully demonstrated the ability and proficiency to service, repair, and maintain the subject JLG product model.

Reference Table 2-2, MVL/MSP - Preventive Maintenance & Inspection Schedule., and the appropriate areas of this manual for servicing and maintenance procedures. The frequency of service and maintenance must be increased as environment, severity and frequency of usage requires.

Table 2-1. Inspection and Maintenance

Type	Frequency	Primary Responsibility	Service Qualification	Reference
Pre-Start Inspection	Prior to use each day; or At each Operator change.	User or Operator	User or Operator	Operator and Safety Manual
Pre-Delivery Inspection	Prior to each sale, lease, or rental delivery.	Owner, Dealer, or User	Qualified JLG Mechanic	Service and Maintenance Manual and applicable JLG inspection form.
Frequent Inspection	In service for 3 months; or Out of service for a period of more than 3 months; or Purchased used.	Owner, Dealer, or User	Qualified JLG Mechanic	Service and Maintenance Manual and applicable JLG inspection form.
Annual Machine Inspection	Annually, no later than 13 months from the date of the prior inspection.	Owner, Dealer, or User	Qualified JLG Mechanic	Service and Maintenance Manual and applicable JLG inspection form.
Preventative Maintenance	At intervals as specified in the Service and Maintenance Manual.	Owner, Dealer, or User	Qualified JLG Mechanic	Service and Maintenance Manual

2.2 PREVENTIVE MAINTENANCE AND INSPECTION SCHEDULE

(See Table 2-2.)

The preventive maintenance and inspection checks are listed and defined in the following table. This table is divided into two basic parts, the “AREA” to be inspected and the “INTERVAL” at which the inspection is to take place. Under the “AREA” portion of the table, the various systems along with the components that make up that system are listed. The “INTERVAL” portion of the table is divided into five columns representing the various inspection time periods. The numbers listed within the interval column represent the applicable inspection code for which that component is to be checked.

The checks and services listed in this schedule are not intended to replace any local or regional regulations that may pertain to this type of equipment nor should the lists be considered as all inclusive. Variances in interval times may occur due to climate and/or conditions and depending on the location and use of the machine.

Table 2-2. MVL/MSP - Preventive Maintenance & Inspection Schedule.

AREA ON MACHINE	INTERVAL				
	PRE-START (a) INSPECTION	3 MONTH PREVENTATIVE MAINTENANCE	6 MONTH PREVENTATIVE MAINTENANCE	PRE-DELIVERY (b) OR FREQUENT (c) INSPECTION	ANNUAL (d) (YEARLY) INSPECTION
MAST ASSEMBLY	7				
Mast Sections				2, 5	2, 5
Chain Systems			14	3, 14	14, 25
Sequence Cable Systems				3	1, 2, 3
Covers or Shields					1
Sheave Systems				1, 2	1, 2
Bearings					1, 2
Slide Pads					1, 2
PLATFORM ASSEMBLY	7				
Platform				1	1
Guard Rails				1, 2, 4	1, 2, 4
Gate				1, 5	1, 5
Floor				1, 2	1, 2
Extension Deck Assembly				1, 5	1, 5
Lanyard Anchorage Point				1, 4	1, 4
CHASSIS ASSEMBLY	7				
Pot Hole Protection System				5	5
Battery and Valve Covers or Doors				1, 7	1, 7
Static Strap					1
Caster Wheels	1, 2	14		1, 2	1, 2
Drive Wheels				2	2
Gear Box Assembly *		1, 7, 9, 11			
Drive Motor Brushes **					—
Brake Release				5	5
FUNCTIONS/CONTROLS	7				
Platform Controls				5, 6, 7	5, 6, 7
Ground Controls				5, 6	5, 6, 14
Function Control Locks, Guards, or Detents				5	5
Function Enable System					
Emergency Stop Switches (Ground & Platform)					5
Function Limit or Cutout Switch Systems				5	
Drive Brakes					5
Manual Descent or Auxiliary Power				5	5
POWER SYSTEM					
Batteries	19			9	18
Battery Charger					5
HYDRAULIC/ELECTRIC SYSTEM	9				
Hydraulic Pump				1, 2, 9	1, 2, 5, 9
Hydraulic Cylinder				2, 7, 9	2, 9
Cylinder Attachment Pins and Pin Retainers				1, 2	1, 2
Hydraulic Hoses, Lines, and Fittings				1, 9	1, 9
Hydraulic Reservoir, Cap, and Breather				5, 7	5, 7
Hydraulic Filter					

SECTION 2 - GENERAL

Table 2-2. MVL/MSP - Preventive Maintenance & Inspection Schedule. (Continued)

AREA ON MACHINE	INTERVAL				
	PRE-START (a) INSPECTION	3 MONTH PREVENTATIVE MAINTENANCE	6 MONTH PREVENTATIVE MAINTENANCE	PRE-DELIVERY (b) OR FREQUENT (c) INSPECTION	ANNUAL (d) (YEARLY) INSPECTION
Hydraulic Fluid ***	11			11	11
Electrical Connections				20	20
Instruments, Gauges, Switches, Lights, Horn	5				
GENERAL					
Operator and Safety Manual in Storage Box	21			21	21
ANSI and EMI Manuals/Handbooks Installed	21			21	21
Capacity Decals Installed, Secure, Legible	21			21	21
All Decals/Placards Installed, Secure, Legible	21			21	21
"Walk-Around" Inspection Performed	22				
Annual Machine Inspection Due					21
No Unauthorized Modifications or Additions				21	21
All Relevant Safety Publications Incorporated				21	21, 22
General Structural Condition and Welds				2, 4	2, 4
All Fasteners, Pins, Shields, and Covers					1, 2
Grease and Lubricate to Specifications				22	22
Function Test of All Systems	22			22	
Paint and Appearance				7	7
Notify JLG of Change in Machine Ownership					22

* Change only when serviced, requires 10 oz. (296cc's) to fill.

** Replace after system brush wear indicator warning is activated on Ground Control Station.

*** Drain and refill with fresh hydraulic fluid every two years.

Inspection and Maintenance Codes:

- | | |
|---|---|
| <ol style="list-style-type: none"> 1. Check for proper and secure installation. 2. Visual inspection for damage, cracks, distortion, or excessive wear. 3. Check for proper adjustment. 4. Check for cracked or broken welds. 5. Operates properly. 6. Returns to neutral or "off" position when released. 7. Clean and free of debris. 8. Interlocks function properly. 9. Check for signs of leakage. 10. Decals installed and legible. 11. Check for proper fluid level. 12. Check for chafing and proper routing. 13. Check for proper tolerances. 14. Properly lubricated. 15. Torqued to proper specification. | <ol style="list-style-type: none"> 16. No gouges, excessive wear, or cords showing. 17. Properly inflated and seated around rim. 18. Proper and authorized components. 19. Fully charged. 20. No loose connections, corrosion, or abrasions. 21. Verify. 22. Perform. 23. Sealed properly. 24. Overrides Platform controls. 25. Inspected per Service and Maintenance Manual. |
|---|---|

Footnotes:

- (a) Prior to use each day; or at each Operator change
- (b) Prior to each sale, lease, or delivery
- (c) In service for 3 months; or Out of service for 3 months or more; or Purchased used
- (d) Annually, no later than 13 months from the date of the prior annual inspection

2.3 SERVICING AND MAINTENANCE GUIDELINES

General

The following information is provided to assist you in the use and application of servicing and maintenance procedures contained in this chapter.

Safety and Workmanship

Your safety, and that of others, is the first consideration when engaging in the maintenance of equipment. Always be conscious of component weight. Never attempt to move heavy parts without the aid of a mechanical device. Do not allow heavy objects to rest in an unstable position. When raising a portion of the equipment, ensure that adequate support is provided.



NEVER WORK UNDER AN ELEVATED PLATFORM UNTIL PLATFORM HAS BEEN SAFELY RESTRAINED FROM ANY MOVEMENT BY BLOCKING OR OVERHEAD SLING.

Cleanliness

The most important single item in preserving the long service life of a machine is to keep dirt and foreign materials out of the vital components. Precautions have been taken to safeguard against this. Shields, covers, seals, and filters are provided to keep the wheel bearings, mast sections and oil supply clean; however, these items must be maintained on a scheduled basis in order to function properly.

At any time when oil lines are disconnected, clear adjacent areas as well as the openings and fittings themselves. As soon as a line or component is disconnected, cap or cover all openings to prevent entry of foreign matter.

Clean and inspect all parts during servicing or maintenance, and assure that all passages and openings are unobstructed. Cover all parts to keep them clean. Be sure all parts are clean before they are installed. New parts should remain in their containers until they are ready to be used.

Components Removal and Installation

Use adjustable lifting devices, whenever possible, if mechanical assistance is required. All slings (*chains, cables, etc.*) should be parallel to each other and as near perpendicular as possible to top of part being lifted.

Should it be necessary to remove a component on an angle, keep in mind that the capacity of an eyebolt or similar bracket lessens, as the angle between the supporting

structure and the component becomes less than 90 degrees.

If a part resists removal, check to see whether all nuts, bolts, cables, brackets, wiring, etc., have been removed and that no adjacent parts are interfering.

Component Disassembly and Reassembly

When disassembling or reassembling a component, complete the procedural steps in sequence. Do not partially disassemble or assemble one part, then start on another. Always recheck your work to assure that nothing has been overlooked. Do not make any adjustments, other than those recommended, without obtaining proper approval.

Pressure-Fit Parts

When assembling pressure-fit parts, use an “anti-seize” or molybdenum disulfide base compound to lubricate the mating surface.

Bearings

When a bearing is removed, cover it to keep out dirt and abrasives. Clean bearings in nonflammable cleaning solvent and allow to drip dry. Compressed air can be used but do not spin the bearing.

Discard bearings if the races and balls (*or rollers*) are pitted, scored, or burned.

If bearing is found to be serviceable, apply a light coat of oil and wrap it in clean (*waxed*) paper. Do not unwrap reusable or new bearings until they are ready to install.

Lubricate new or used serviceable bearings before installation. When pressing a bearing into a retainer or bore, apply pressure to the outer race. If the bearing is to be installed on a shaft, apply pressure to the inner race.

Gaskets

Check that holes in gaskets align with openings in the mating parts. If it becomes necessary to hand-fabricate a gasket, use gasket material or stock of equivalent material and thickness. Be sure to cut holes in the right location, as blank gaskets can cause serious system damage.

Bolt Usage and Torque Application

Use bolts of proper length. A bolt which is too long will bottom before the head is tight against its related part. If a bolt is too short, there will not be enough thread area to engage and hold the part properly. When replacing bolts, use only those having the same specifications of the original, or one which is equivalent.

Unless specific torque requirements are given within the text, standard torque values should be used on heat-treated bolts, studs, and steel nuts, in accordance with recommended shop practices or Torque Chart in Section 1.

Hydraulic Lines and Electrical Wiring

Clearly mark or tag hydraulic lines and electrical wiring, as well as their receptacles, when disconnecting or removing them from the unit. This will assure that they are correctly reinstalled.

Hydraulic System

Keep the system clean. If evidence of metal or rubber particles is found in the hydraulic system, drain and flush the entire system.

Disassemble and reassemble parts on clean work surface. Clean all metal parts with non-flammable cleaning solvent. Lubricate components, as required, to aid assembly.

Lubrication and Servicing

Components and assemblies requiring lubrication and servicing are shown in the Lubrication Chart, (See Section-1). Service applicable components with the amount, type, and grade of lubricant recommended in this manual, at the specified intervals. When recommended lubricants are not available, consult your local supplier for an equivalent that meets or exceeds the specifications listed.

Batteries

Clean batteries, using a non-metallic brush and a solution of baking soda and water. Rinse with clean water. After cleaning, thoroughly dry batteries and coat terminals with an anti-corrosion compound.

Mast Chain Inspection Procedure

Inspect mast chains for the following conditions:

Wear: Always inspect that segment of chain that operates over a sheave. As the chain flexes over the sheaves, joints and plate edges very gradually wear. Chain “stretch” can be measured using a manufacturers wear scale or steel tape. When chains have elongated 3% they must be removed and replaced. Refer to Table 2-3 following for proper chain specifications and allowable stretch tolerances. Peening and wear of chain plate edges are caused by sliding over a chain worn contact face of a sheave, or unusually heavy loads. All of the above require replacement of the chain and correction of the cause. Chain side wear, noticeable when pin heads and outside plates show a definite wear pattern, is caused by misalignment of the sheave/chain anchors and must be corrected promptly. Do not repair chains; if a section of chain is damaged, replace the entire chain set.



Example
 H for a 1" chain = 0.950"
 Maximum wear = 5% of 0.950" = 0.047"
 Minimum plate depth = 0.950" - 0.047" = 0.903"

Rust and Corrosion: Rust and corrosion will cause a major reduction in the load carrying capacity of the chain, because these are primary reasons for side plate cracking. The initial lubrication at the factory is applied in a hot dip tank to assure full penetration into the joint. Do not steam clean or degrease chains. At time of chain installation, factory lube must be supplemented by a maintenance program to provide a film of oil on the chains at all times. If chains are corroded, they must be inspected, especially the outside plates, for cracks in-line with the pins. If cracks are found, replace the chain; if no cracks are discovered, lubricate the chains by dipping in heated oil, and reinstall on the machine. Keep chains lubricated.

Table 2-3. Chain Stretch Tolerance

Chain Size	Pin to Pin Measurement	Allowable Stretch
.50" pitch	12" or 24 pitches	.24 in./12 in. span
.625 pitch	15" or 24 pitches	.30 in./15 in. span

Fatigue Cracks: Fatigue is a phenomenon that affects most metals, and is the most common cause of chain plate failures. Fatigue cracks are found through the link holes, perpendicular (90 degrees) from the pin in-line position. Inspect chains carefully after long time use and heavy loading for this type of crack. If any cracks are discovered, replace all chains, as seemingly sound plates

are on the verge of cracking. Fatigue and ultimate strength failures on JLG Lifts are incurred as a result of severe abuse as design specs are well within the rated lifting capacity of these chains.



Tight Joints: All joints in the leaf chain should flex freely. On leaf chain, tight joints are usually caused by rust/corrosion, or the inside plates “walking” off the bushing. Limber up rusty/corroded chains (*after inspecting care fully*) with a heavy application of oil (*preferably a hot oil dip*). Tap inside “walking” plates inward; if “walking” persists, replace the chain. This type of problem is accelerated by poor lubrication maintenance practice, and most tight joint chains have been operated with little or no lubrication. Tight joints on leaf chain are generally caused by:

- a. Bent pins or plates.
- b. Rusty joints.
- c. Peened plate edges.

Oil rusty chains, and replace chains with bent or peened chain components. Keep chains lubricated.

TIGHT JOINTS



Protruding or Turned Pins: Chains operating with inadequate lube generate tremendous friction between the pin and plates (pin and bushing on leaf chain). In extreme cases, this frictional torque can actually turn the pins in the outside press-fit plates. Inspect for turned pins, which can be easily spotted as the “V” flats on the pin heads are no longer in line. Replace all chains showing evidence of turned or protruding pins. Keep chains lubricated.

Stress Corrosion Cracking: The outside link plates, which are heavily press-fitted to the pins, are particularly susceptible to stress corrosion cracking. Like fatigue cracks, these initiate at the point of highest stress (aper-

ture) but tend to extend in an arc-like path, often parallel to the rolling grain of the material.

ABNORMAL PROTRUSION OR TURNED PINS

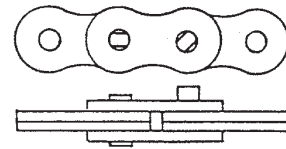

Also, more than one crack can often appear on a link plate. In addition to rusting, this condition can be caused by exposure to an acidic or caustic medium or atmosphere. Stress corrosion is an environmentally assisted failure. Two conditions must be present; corrosive agent and static stress.

ARC-LIKE CRACKED PLATES (STRESS CORROSION)

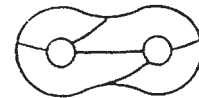

In the chain, static stress is present at the aperture due to the press fit pin. No cycle motion is required and the plates can crack during idle periods. The reactions of many chemical agents (such as battery acid fumes) with hardened metals liberate hydrogen which attacks and weakens the metal grain structure.

Chain Anchors and Sheaves: An inspection of the chain must include a close examination of chain anchors and sheaves. Check chain anchors for wear breakage and misalignment. Anchors with worn or broken fingers should be replaced. They should also be adjusted to eliminate twisting the chain for an even load distribution.

Inspect the sheaves, sheave bearings, sheave grooves and pins for extreme wear, replace as necessary. A worn sheave can mean several problems, as follows:

- a. Chains too tight.
- b. Sheave bearings/pin bad.
- c. Bent/misaligned chains.

2.4 LUBRICATION INFORMATION

Hydraulic System

The primary enemy of a hydraulic system is contamination. Contaminants enter the system by various means, e.g., using inadequate hydraulic oil, allowing moisture, grease, filings, sealing components, sand, etc., to enter when performing maintenance, or by permitting the pump to cavitate due to insufficient system warm-up or leaks in the pump supply.

The design and manufacturing tolerances of the component working parts are very close, therefore, even the smallest amount of dirt or foreign matter entering a system can cause wear or damage to the components and generally results in faulty operation. Every precaution must be taken to keep hydraulic oil clean, including reserve oil in storage.

Cloudy oils indicate a high moisture content which permits organic growth, resulting in oxidation or corrosion. If this condition occurs, the system must be drained, flushed, and refilled with clean oil.

It is not advisable to mix oils of different brands or types, as they may not contain the same required additives or be of comparable viscosities. Good grade mineral oils, with viscosities suited to the ambient temperatures in which the machine is operating, are recommended for use.

NOTE: *Metal particles may appear in the oil of new machines due to the wear-in of meshing components.*

Hydraulic Oil

For best performance, JLG recommends the use of ISO-Vg grade 32, 46 oil with a viscosity range between 15-250 SUS at 100 degrees F (*32-54 cST at 40 degrees C*). Refer to Section 1 of this Service Manual for recommended hydraulic oils.

Changing Hydraulic Oil

Use of any of the recommended hydraulic oils eliminates the need for changing the oil on a regular basis. If it is necessary to change the oil, use only those oils meeting or exceeding the specifications appearing in this manual. If unable to obtain the same type of oil supplied with the machine, consult local supplier for assistance in selecting the proper equivalent. Avoid mixing petroleum and synthetic base oils. JLG Industries recommends changing the hydraulic oil annually.

Use every precaution to keep the hydraulic oil clean. If the oil must be poured from the original container into another, be sure to clean all possible contaminants from the service container.

While the unit is shut down, a good preventive maintenance measure is to make a thorough inspection of all hydraulic components, lines, fittings, etc., as well as a functional check of each system, before placing the machine back in service.

Lubrication Specifications

Specified lubricants, as recommended by the component manufacturers, are always the best choice, however, multi-purpose greases usually have the qualities which meet a variety of single purpose grease requirements. Should any question arise regarding the use of greases in maintenance stock, consult your local supplier for evaluation. Refer to Section-1 in this Service Manual for an explanation of the lubricant key designations appearing in the Lubrication Chart.

SECTION 3. BASE COMPONENTS

3.1 BASE ASSEMBLY COMPONENTS

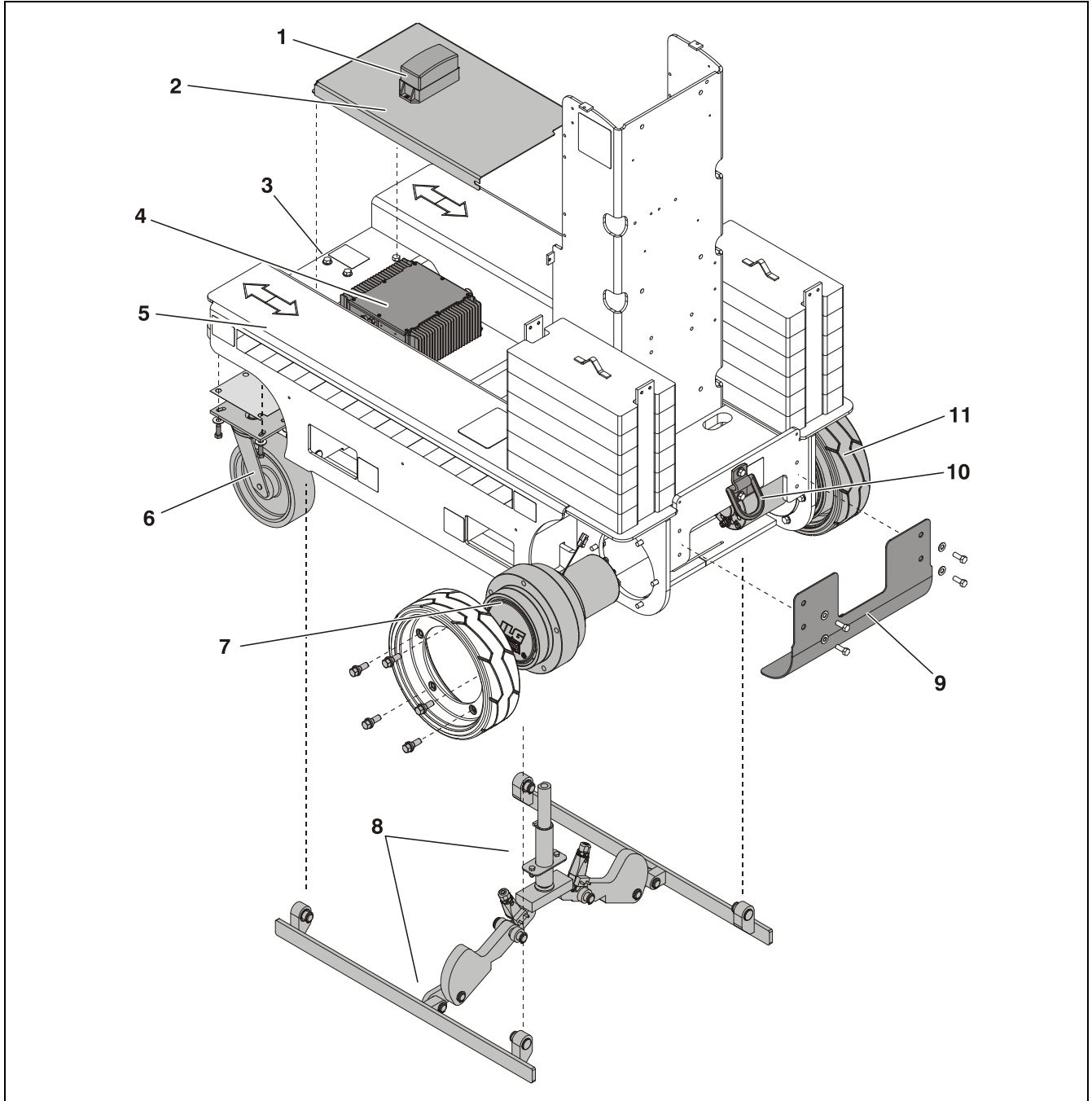

Figure 3-1. Base Components.

- 1. Base Mounted Beacon
- 2. Battery Charger Cover
- 3. Front Tie Down Lug
- 4. Battery Charger Assembly

- 5. Base Frame
- 6. Front Caster Wheel Assembly
- 7. Left Drive Motor Assy.
- 8. Pot Hole Protection System

- 9. Drive Motor Cover
- 10. Rear Tie Down Lug
- 11. Right Drive Motor Assy.

3.2 BASE FRAME COVERS

Drive Motor Cover - Installation

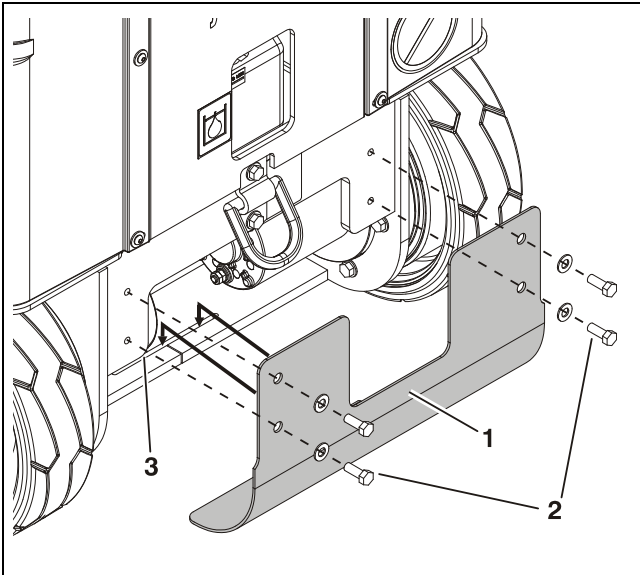

Drive Motor Cover Installation

1. Cover
2. Attach Screws and Washers (a)
3. Set Cover Tab on Lower portion of Cover, in Slot on Base Frame

NOTE: (a) Apply Loctite #242 to screw threads before tightening.

Battery Charger Cover - Installation

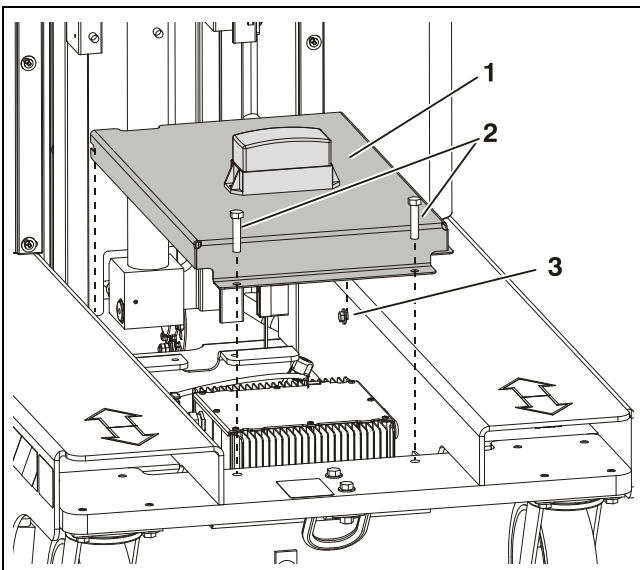

Battery Charger Cover Installation

1. Charger Cover
2. Front Attach Screws and Washers
3. Rear Attach Screws and Washers - Loosen Only - Cover Slotted

3.3 DRIVE/ELEVATION CUT-OUT SWITCH INSTALLATION

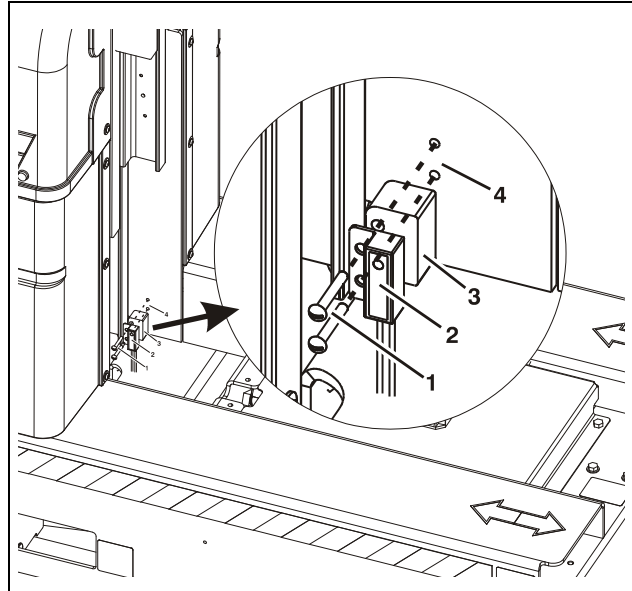

Drive/Elevation Switch Cut-Out Switch Installation

1. Mounting Screws (a)
2. Proximity Switch (b)
3. Switch Mounting Block
4. Frame Mounting Holes

NOTE: Elevate and block platform to gain access to switch.

(a) Apply Loctite #242 to mounting screw threads on final assembly.

3.4 DRIVE AND CASTER WHEELS

Tire Wear and Damage

Inspect tires periodically for wear or damage. Tires with worn edges or distorted profiles require replacement. Tires with significant damage in the tread area or side wall, require immediate evaluation before replacing the machine into service.

Wheel and Tire Replacement

Replacement wheels must have the same diameter and profile as the original. Replacement tires must be the same size and rating as the tire being replaced.

Wheel Installation

It is extremely important to apply and maintain proper wheel mounting torque.

⚠ WARNING

WHEEL LUG NUTS MUST BE INSTALLED AND MAINTAINED AT THE PROPER TORQUE TO PREVENT LOOSE WHEELS, BROKEN LUG NUTS, AND POSSIBLE SEPARATION OF WHEEL FROM THE AXLE. BE SURE TO USE ONLY THE LUG NUTS MATCHED TO THE CONE ANGLE OF THE WHEEL.

Tighten the lug nuts to the proper torque to prevent wheels from coming loose. Use a torque wrench to tighten the fasteners. If you do not have a torque wrench, tighten the fasteners with a lug wrench, then immediately have a service garage or dealer tighten the lug nuts to the proper torque. Over-tightening will result in breaking the lug nuts or permanently deforming the mounting holes in the wheels. The proper procedure for attaching wheels is as follows:

1. Start all lug nuts by hand to prevent cross threading. DO NOT use a lubricant on threads or nuts.
2. Tighten lug nuts in the following sequence.

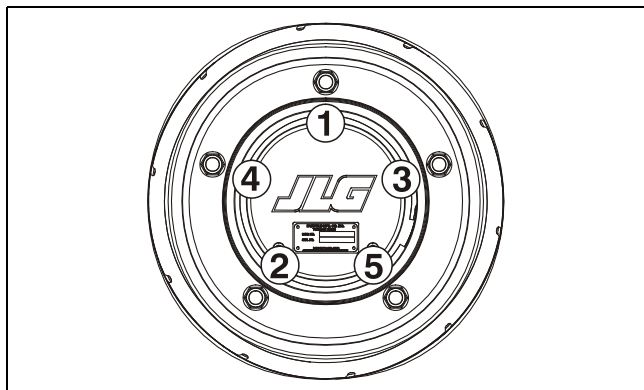

Figure 3-2. Wheel Lug Nut Tightening Sequence

3. The tightening of the lug nuts should be done in stages. Following the recommended sequence, tighten lug nuts per wheel torque.

Table 3-1. Wheel Torque Chart

TORQUE SEQUENCE		
1st Stage	2nd Stage	3rd Stage
20-30 ft lbs (28 - 42 Nm)	65-80 ft lbs (91 - 112 Nm)	105 -120 ft lbs (142 - 163 Nm)

4. Wheel lug nuts should be torqued after the first 50 hours of operation and after each wheel removal. Check torque every 3 months or 150 hours of operation.

Caster Wheels - Installation

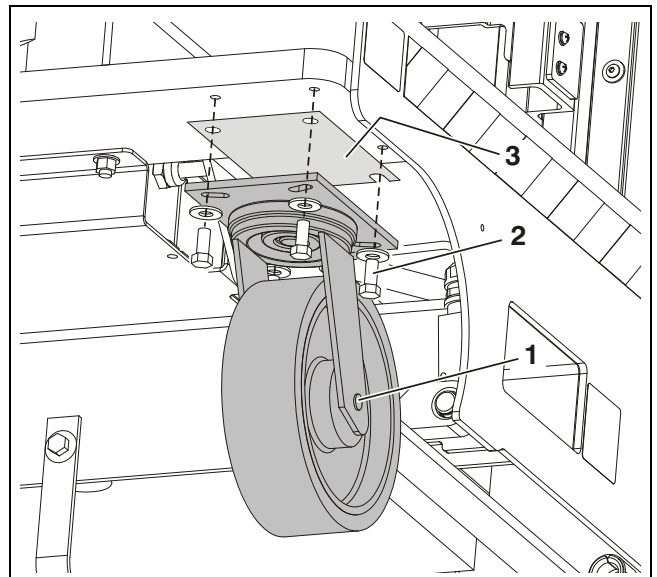

Caster Wheel - Installation

1. Caster Wheel Assembly
2. Attach Screws and Washers (Qty. 4) (a)
3. Caster Shim (b)

NOTE: (a) On assembly, apply Loctite 242 to threads.
 (b) As required; Place unit on a flat surface, shim a caster wheel that is consistently more than .015" off of flat surface.

3.5 WHEEL DRIVE ASSEMBLY - SERVICING

The component parts of the left and right drive motor assemblies are identical. The left drive motor is run in the reverse direction of the right motor.

Roll And Leak Testing

Torque-Hub units should always be roll and leak tested before disassembly and after assembly to make sure that the unit's gears, bearings and seals are working properly. The following information briefly outlines what to look for when performing these tests.

NOTE: *The brake must be released before performing the roll test. This can be accomplished by supplying 24 Volts D.C. to the gray 2-pin brake connector.*

The Roll Test

The purpose of the roll test is to determine if the unit's gears are rotating freely and properly. You should be able to rotate the wheel or hub of the gearbox by hand. If you feel more drag in the gears only at certain points, then the gears are not rolling freely and should be examined for improper installation or defects. Some gear packages roll with more difficulty than others. Do not be concerned if the gears in your unit seem to roll hard as long as they roll with consistency.

The Leak Test

The purpose of a leak test is to make sure the unit is air tight. You can tell if your unit has a leak if the pressure gauge reading on your leak checking fitting starts to fall after the unit has been pressurized and allowed to equalize. Leaks will most likely occur at the pipe plugs, the main seal or wherever o-rings are located. The exact location of a leak can usually be detected by brushing a soap and water solution around the main seal and where the o-rings or gaskets meet on the exterior of the unit, then checking for air bubbles. If a leak is detected in a seal, o-ring or gasket, the part must be replaced, and the unit rechecked. Leak test at 10 psi for 20 minutes.

NOTE: *Due the small air volume inside this Torque-Hub, it will pressurize to 10 psi very quickly. If the pressure becomes excessive in the unit the seals will be destroyed.*

Oil Type & Capacity

This torque hub unit is shipped with ISO 68 viscosity oil (hydraulic fluid). It is designed to utilize the same oil throughout its service life. However, should it need to be serviced the oil will need to be drained and replaced.

In the event of servicing, fill the unit with ISO grade 68 oil or oil of a similar viscosity (*80W gear oil or 20W engine oil*).

The gearbox will need to be filled with 10 oz. of oil.

Oil Filling Instructions

10 oz. of gearbox oil will fill the gearbox cavity approximately half full. To check the oil level, rotate the wheel so that the cover plugs are at 12 o'clock and 3 o'clock. Allow the oil to settle. Slowly loosen the 3 o'clock plug. If oil begins to come out then the oil level is sufficient. If no oil is noticed at the 3 o'clock plug location, then remove both plugs. Slowly add oil at the 12 o'clock plug location until oil begins to seep out of the 3 o'clock plug location. Reinstall and tighten plugs to 6-8 ft-lbs.

Drive Motor Brush Wear - Warning Indication

The machines drive motors include brush wear sensors that activate a warning indicating the drive motor brushes will require replacement soon. This warning protects the drive motors from damage due to extreme brush wear.

When the brush wear warning is activated the Ground Control Station LCD screen will indicate a fault code of 6, also the hour-meter is set to countdown 25 hours of (DRIVE) operation remaining.

The Platform Control LEDs will indicate this warning with 8 flashing LEDs and an intermittent beep.

Only the drive function when used will affect the hour meter count down once the warning has been activated. The machine will operate normally until the last 10 seconds of the 25 hour countdown.

During the last 10 seconds of the 25 hour (DRIVE) countdown the machine will only drive in creep/turtle drive mode and platform lift up will be disabled. At this point cycling power on/off will only repeat the final 10 second mode cycle.

The machine will not operate normally until the drive motor brushes are replaced (*repositioning the brush warning sensors*), and the Ground Control Station is programmed to reset the Brush Wear - Warning Timer - see Section 4.6, Ground Control Module - Programming of this manual.

Wheel Drive Assembly - Removal From Machine

The electric wheel drive assemblies are mounted independent of each other in the base frame at the rear of the machine.

The wheel drive assembly consists of an 24V DC electric motor driving a 30.68:1 ratio gear box, the assembly also included a friction disk parking brake assembly. This brake assembly is mounted internally on the drive assembly between the drive motor and the gear box assembly.

1. Disconnect the positive battery terminal from the left side battery.
2. Raise the rear drive wheels of the machine off the ground, use a fork truck or floor jack. Place a block or safety stand under machine.

3. Remove the wheel drive cover assembly.
4. Remove the drive wheel mounting lugs and remove the drive wheel(s).
5. Disconnect the power harness terminals and brake harness connector(s) from the drive motor.
6. Remove the six (6) hex head cap screws and washers attaching the drive assembly to the frame.
7. Carefully slide the drive motor assembly out of the base frame for disassembly.

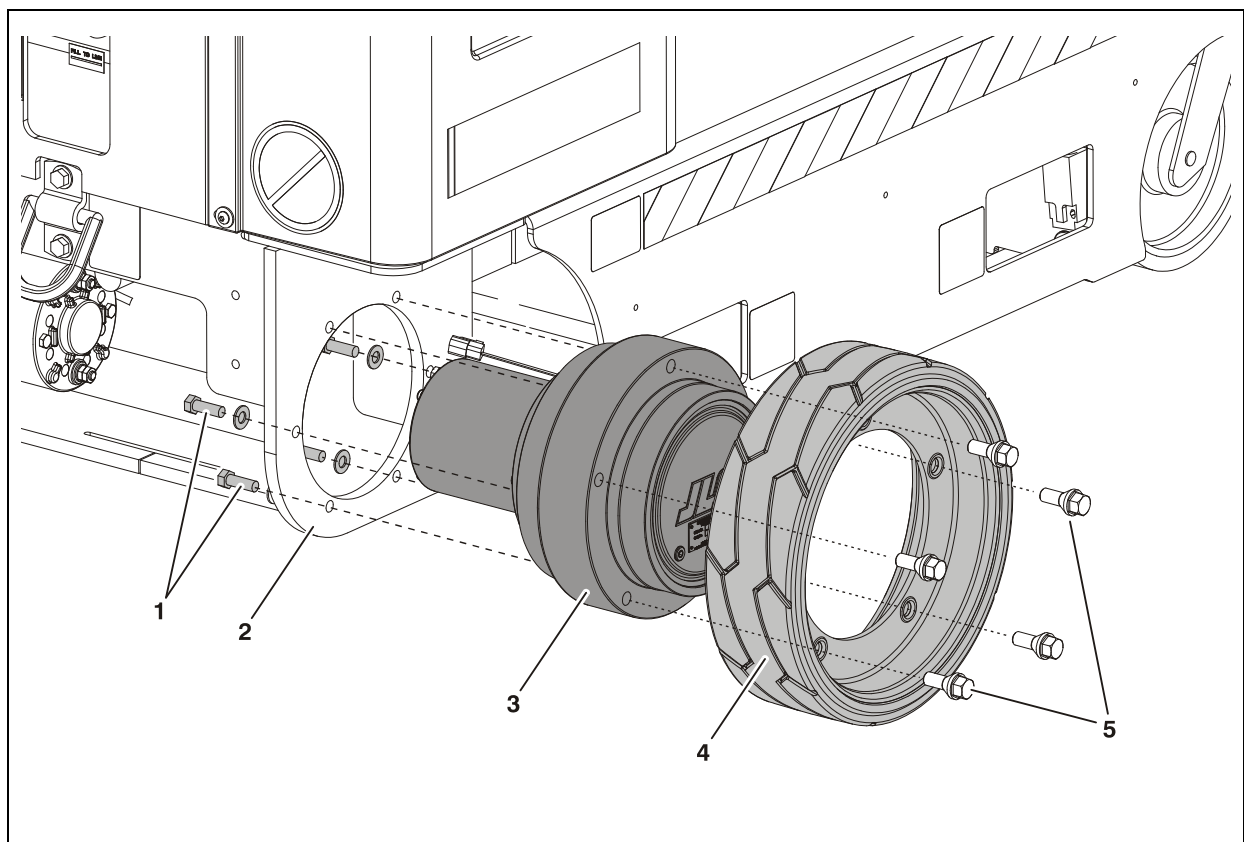

Wheel Drive Assembly - Installation (Right Side Shown)

- | | |
|---|--|
| <ol style="list-style-type: none"> 1. Mounting Bolts/Washers (a) 2. Frame Mounting Surface 3. Wheel Drive Assembly | <ol style="list-style-type: none"> 4. Drive Wheel 5. Wheel Mounting Lugs (b) |
|---|--|

NOTE: Installation same for left and right drive motor - (a) Apply Loctite #242 to threads before tightening.
 (b) Tighten to 120 ft. lbs. (534 N-m)

Wheel Drive Disassembly - Main Components

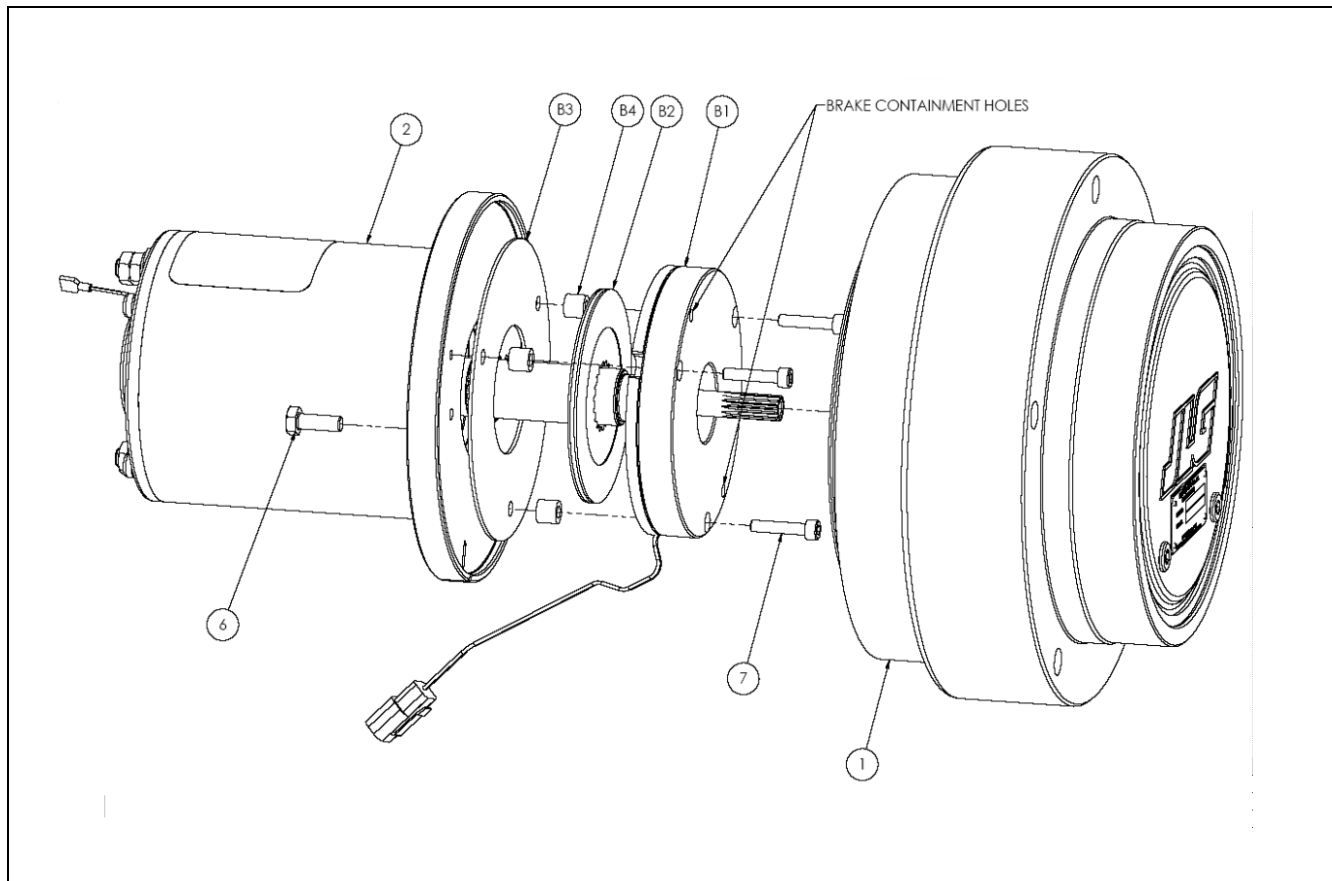

Drive Motor Disassembly - Main Components

NOTE: If possible, remove the wheel drive assembly from the machine frame.

1. Drain the oil from the **Gearbox (1)** by removing the cover plugs in the cover.
2. Remove the 2 **Drive Motor Bolts (6)** and slowly pull the **Motor (2)** out of the gearbox.
3. Obtain and install 2 bolts (M5 x 0.8 - 20mm long) into the brake containment holes. This will keep the brake housing in one piece.
4. Cut the black wire tie (not shown) from the frame of the motor.
5. Remove the 3 **Brake Bolts (7)**.

6. Remove the **Brake Housing (B1)** and the **Spacers (B4)**.

NOTE: The brake wires will have some silicone sealant at the slot through the motor flange. It is okay to pull the wire out of the motor flange slot. The slot will have to be re-sealed during reassembly.

7. Remove the **Brake Disc (B2)** from the splined motor shaft.
8. Remove the **Brake Friction Plate (B3)** from the motor flange.

Replacing Drive Motor Brushes

⚠ CAUTION

THE MOTOR MUST BE DISASSEMBLED FROM THE GEARBOX AND DISCONNECTED FROM THE MACHINE CONTROLLER BEFORE BEGINNING THIS PROCEDURE. SEE WHEEL DRIVE ASSEMBLY - REMOVAL FROM MACHINE AND WHEEL DRIVE DISASSEMBLY - MAIN COMPONENTS ON THE PREVIOUS PAGES.

1. Wrap tape around the end of the motor shaft that interfaces with the gearbox to avoid damage to this area.
2. Remove the motor thru bolts.
3. Remove the motor flange/brake mount from the motor frame.
4. Remove the brush housing from the motor frame and armature by tapping the edge of the brush housing with a soft-tipped mallet. The brushes will spring towards the center of the brush housing once it has separated from the armature.
5. Remove the wave spring washer from the bearing bore of the brush housing and set aside.
6. Pick a brush and remove the screw that fastens its lead to the brush holder.

NOTE: *If this is a wear indicator brush, then there will be a second lead that will need to be removed from a spade terminal in the brush housing.*

7. Remove the brush and brush spring.
8. Inspect the brush holder for corrosion. Remove any corrosion that is found.
9. Install a new brush spring into the brush holder. Make sure that it is oriented in its correct recoil direction.

NOTE: *The spring contains a flat area with a coil at each end. The spring should be oriented such that the bend from the flat area to the coil is towards the brush.*

10. Install a new brush into the brush holder; make sure that the orientation of the lead wire is the same as the other brushes.
11. Push the new brush up into the brush holder. Insert a pin (*straightened paper clip*) into the small hole in the brush housing to keep the brush held up in the brush holder.
12. Connect the brush lead wire to the brush holder; tighten to 30 in-lbs. If this is a wear indicator brush, connect the brush wear indicator lead to the spade terminal in the brush housing.

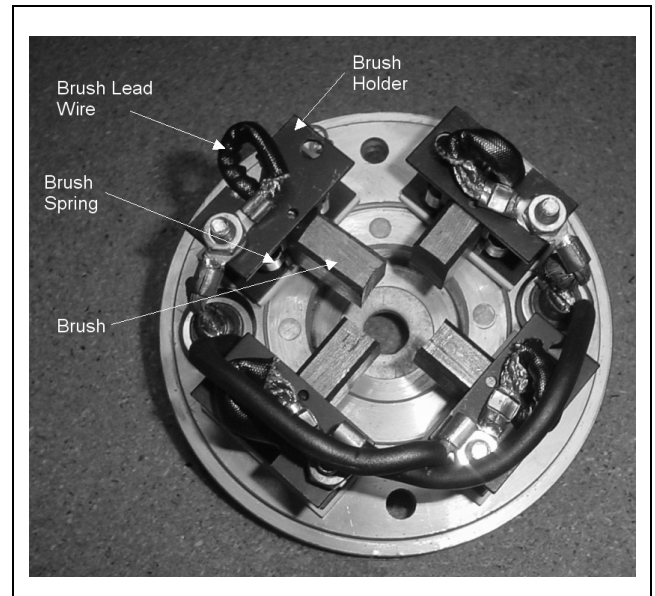

Drive Motor - Brush Holder Components

13. Repeat steps 6 thru 9 for the other 3 brushes.
14. Remove the armature from the motor frame by grabbing onto the commutator and pulling it from the motor frame.

⚠ CAUTION

THE PERMANENT MAGNETS IN THE MOTOR FRAME ARE STRONG AND WILL TRY TO KEEP THE ARMATURE IN THE MOTOR FRAME. MAKE SURE THAT YOU HAVE A FIRM GRIP ON BOTH THE ARMATURE AND THE MOTOR FRAME DURING THIS STEP.

15. Using compressed air, clean out all of the brush dust from the armature, motor frame, adapter plate, and brush holder assembly.
16. Carefully reinstall the armature back into the motor frame. So that the commutator end of the armature is at the end of the frame with the timing marks.

⚠ CAUTION

THE PERMANENT MAGNETS IN THE MOTOR FRAME ARE STRONG AND WILL TRY TO PULL THE ARMATURE IN THE MOTOR FRAME. MAKE SURE THAT YOU HAVE A FIRM GRIP ON BOTH THE ARMATURE AND THE MOTOR FRAME SO THAT YOU CAN CONTROL THE SPEED OF THIS INSTALLATION. BE CAREFUL NOT TO PINCH YOUR FINGERS BETWEEN THE ARMATURE AND THE FRAME.

17. Install the wave spring washer back into the bearing bore of the brush holder assembly. Make sure that it is oriented such that the spring touches the outer raceway of the armature bearing.

SECTION 3 - BASE COMPONENTS

18. Install the brush housing onto the end of the motor frame and armature. You may need to use a soft-tipped mallet to tap the brush housing onto the bearing of the armature. Once the brush housing is partially on the armature, the brush retaining pins must be removed.

NOTE: Do not pinch any wires between the frame and the brush housing.

19. Line up the timing marks between the brush housing and the motor frame.
20. Install the motor bolts.
21. Install the motor flange so that the tapped holes line up with the motor bolts.

NOTICE

WHEN TIGHTENING THE MOTOR HOUSING TO MOUNTING FLANGE, CHECK THAT THE MOUNTING BOLTS ARE NOT PROTRUDING TO FAR THROUGH THE MOTOR MOUNTING FLANGE AND COME INTO CONTACT WITH THE BRAKE FRICTION PLATE ON THE OTHER SIDE OF THE FLANGE. THIS COULD CAUSE THE BRAKE FRICTION PLATE TO BECOME WARPED AND THE BRAKE TO NOT WORK PROPERLY. IF NECESSARY, ADD ANOTHER WASHER UNDER THE HEAD OF THE MOTOR HOUSING MOUNTING BOLTS.

22. Tighten the motor bolts to 65 in-lbs.
23. Look at the timing marks to make sure that they are still aligned. If not, loosen bolts, line up the marks, and then retighten the bolts.
24. Remove the protective tape from the motor shaft.

NOTICE

BEFORE MOUNTING THE DRIVE MOTOR/BRAKE ASSEMBLY TO THE GEAR BOX SPINDLE HUB BE CERTAIN THE BRAKE CAVITY INSIDE THE SPINDLE HUB IS CLEAN, DRY, AND FREE OF ANY OIL RESIDUE.

Gear Box Main Disassembly

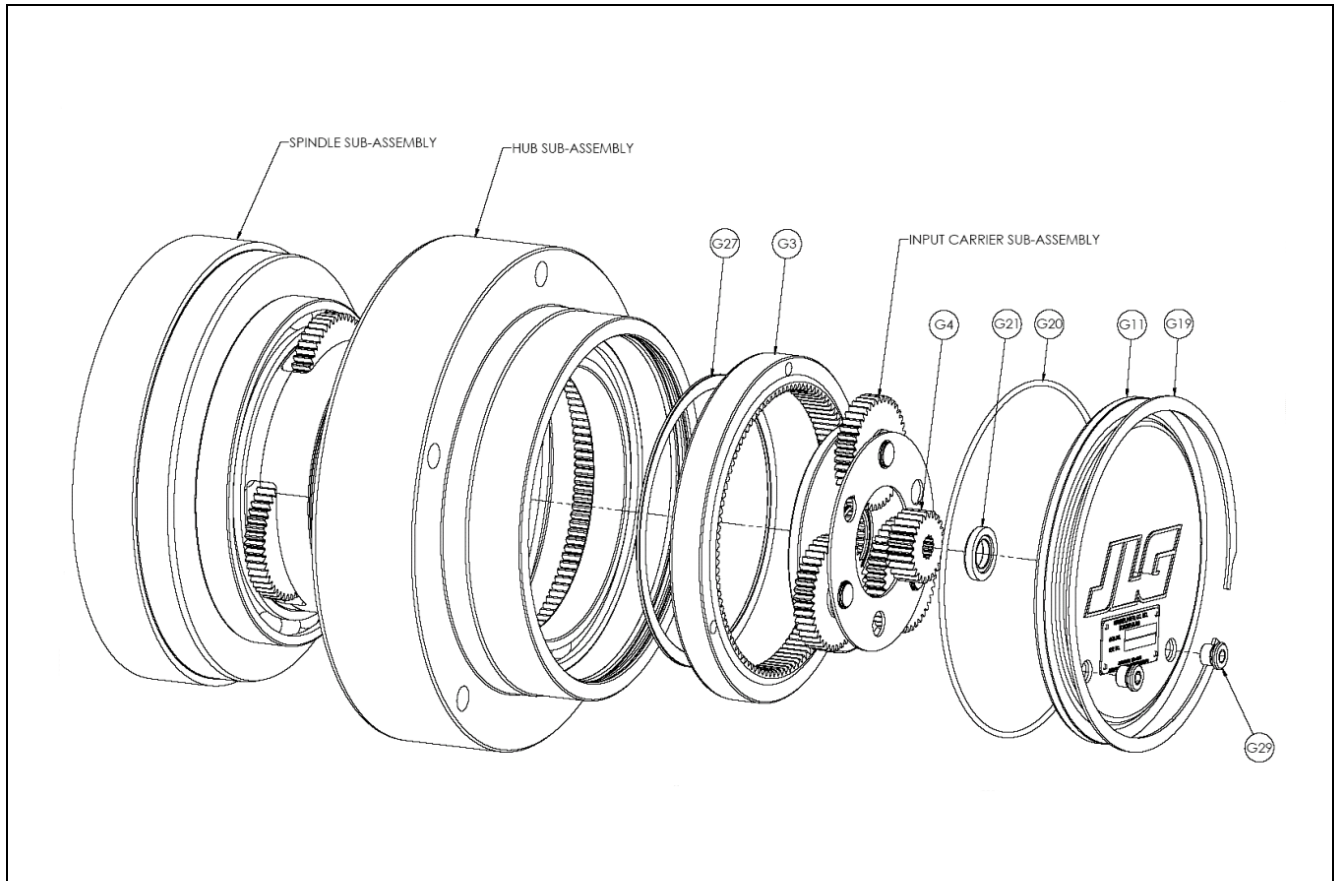

Gear Box Main Disassembly

1. Using a screwdriver, pry the end of the **Retaining Ring (G19)** out of the groove in the **Hub Sub-assembly**, then grasp the loose end of the Retaining Ring and pull the rest of the way out.
 2. Remove **Cover (G11)**, **Thrust Washer (G21)** should remain in the inner counter-bore of the Cover when removed.
- NOTE:** To remove the cover the motor must be removed. Slide a rod through the motor shaft hole and gently tap with a rubber hammer to force the cover out.
3. Remove Input **Sun Gear (G4)**.
 4. Remove Input **Carrier Sub-assembly**.
 5. Remove **Cover (G11)** and **O-ring (G20)**.
 6. Remove Input **Ring Gear (G3)**.
- NOTE:** The Input Ring Gear (G3) is held in with a press fit on its outside diameter. Insert jacking screws (1/4-20UNC, grade 8) with at least 1.5 inches of thread length into each of the three tapped holes to force the ring gear out. Be sure and alternate between the jacking screws to keep the ring gear from becoming misaligned in the bore. The screws will push against the outer race of the main bearing. This bearing will have to be replaced afterwards.
7. Using a screwdriver, remove **Spiral Retaining Ring (G27)**.
 8. Pull **Hub Sub-assembly** off of the **Spindle Sub-assembly**.

Input Carrier Disassembly

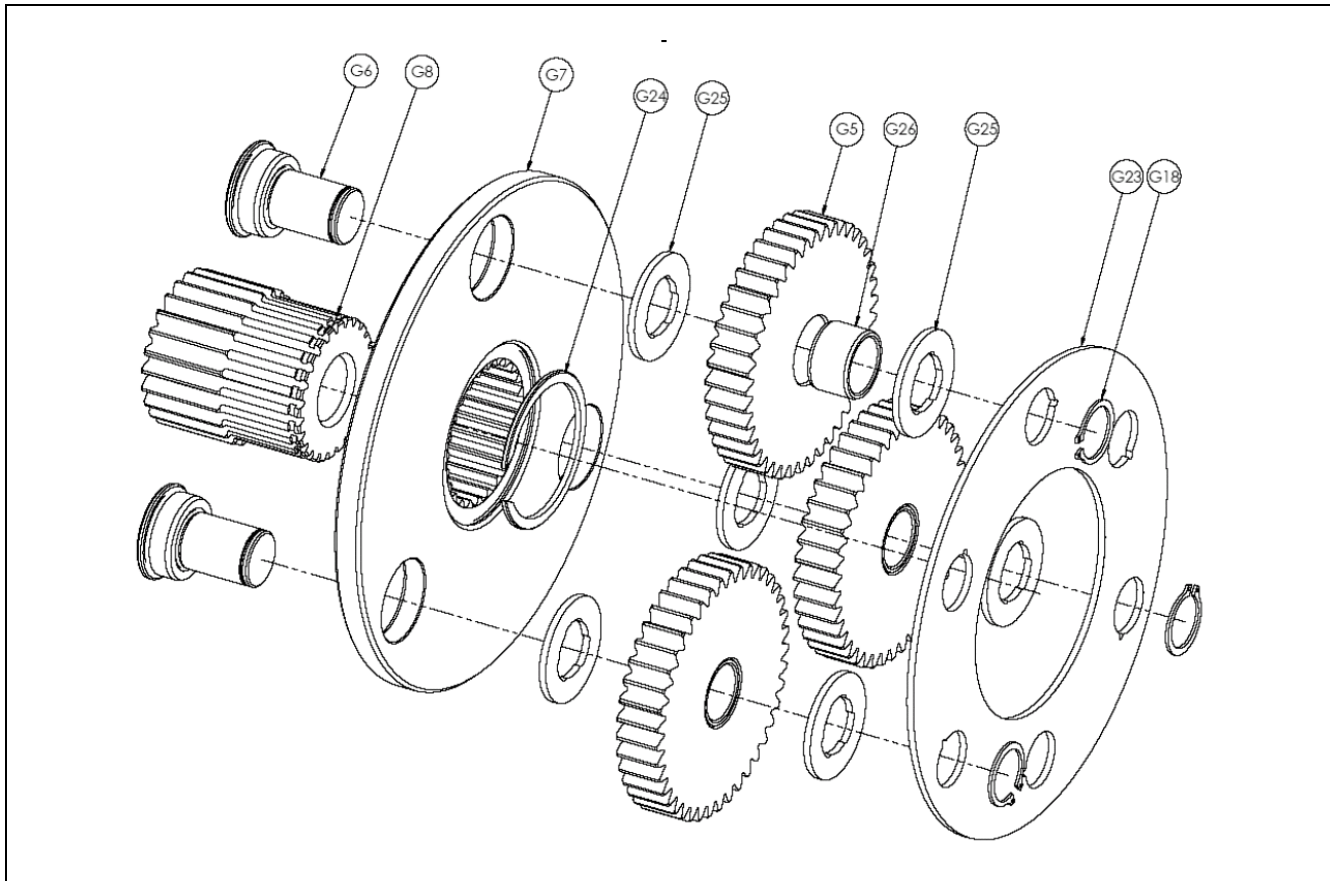

Input Carrier Disassembly

1. Remove **Retaining Rings (G18)** from each of the three **Planet Shafts (G6)**.
9. Remove the three **Planet Shafts (G6)** from the Input Carrier.

NOTE: Do not overstress these Retaining Rings when removing them.

NOTE: The Planet Shafts (G6) are held in with a press fit. To avoid damage to the parts, use an arbor or hydraulic press to remove the Planet Shafts (G6).

2. Remove **Thrust Plate (G23)**.
3. Remove **Thrust Washer (G25)** from each **Planet Shaft (G6)**.
4. Slide each **Input Planet Gear (G5)** off the **Planet Shaft (G6)**.
5. Press out **Bushing (G26)** from the bore of each **Planet Gear (G5)**. Bushings cannot be reused when removed.
6. Remove the other **Thrust Washer (G25)** from each **Planet Shaft (G6)**.
7. Remove **Retaining Ring (G24)** from **Output Sun Gear (G8)**.
8. Slide **Output Sun Gear (G8)** out from the center of the **Input Carrier (G7)**.

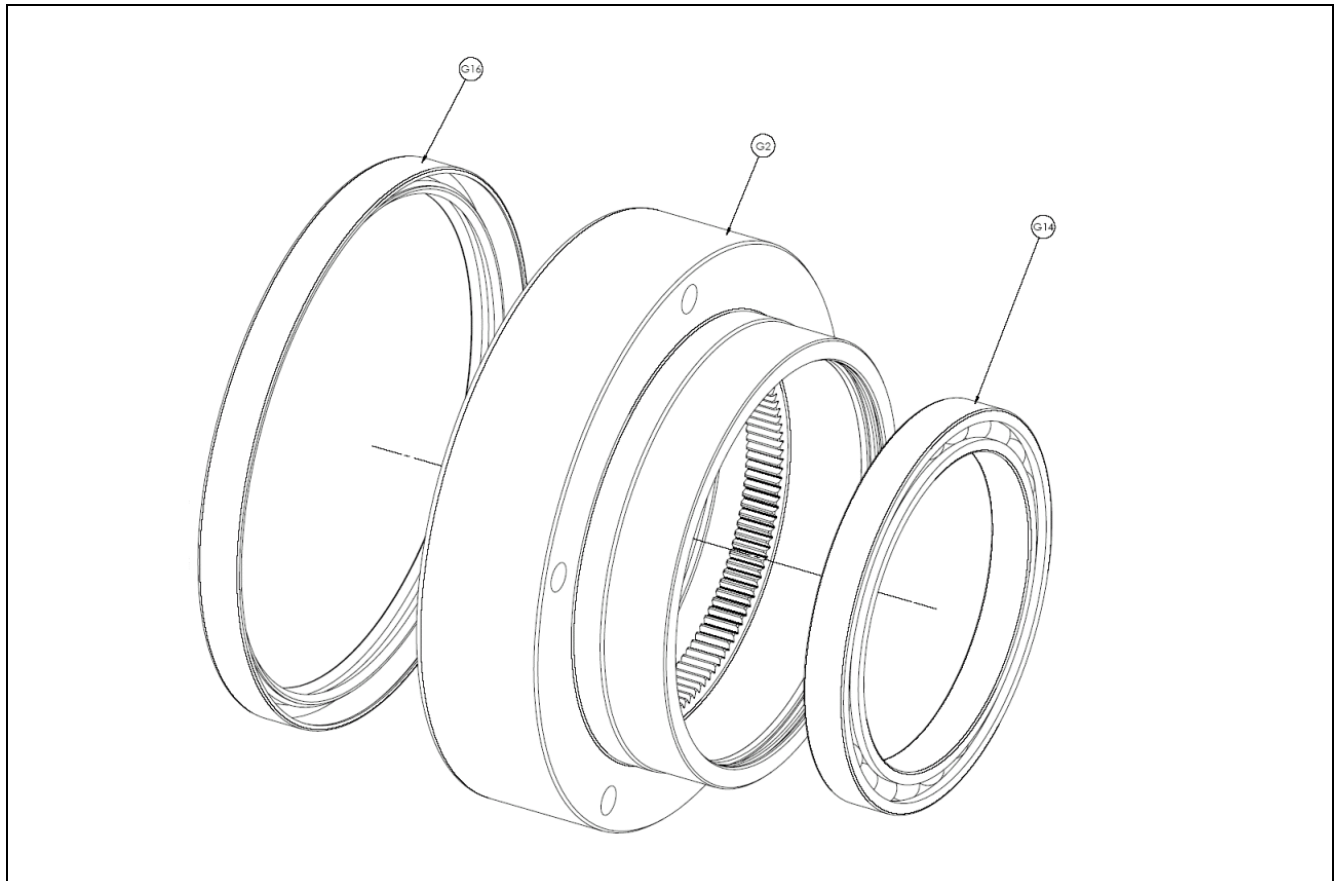
Hub - Disassembly**Hub Disassembly**

1. Remove **Main Wheel Bearing (G14)**.

NOTE: This part is held in the hub with a press fit. To remove have the hub setting seal side up. Use a plate or rod with a large enough diameter push in the inner race of the bearing. Apply force to push the bearing out. This bearing will need to be replaced upon reassembly.

2. Remove main **Lip Seal (G16)**.

NOTE: This Lip Seal (G16) is also held in with a press fit. Remove the Lip Seal only if the hub or seal needs to be replaced. The Lip Seal will most likely become damaged during removal. Try not to damage the hub bore.

Spindle Disassembly

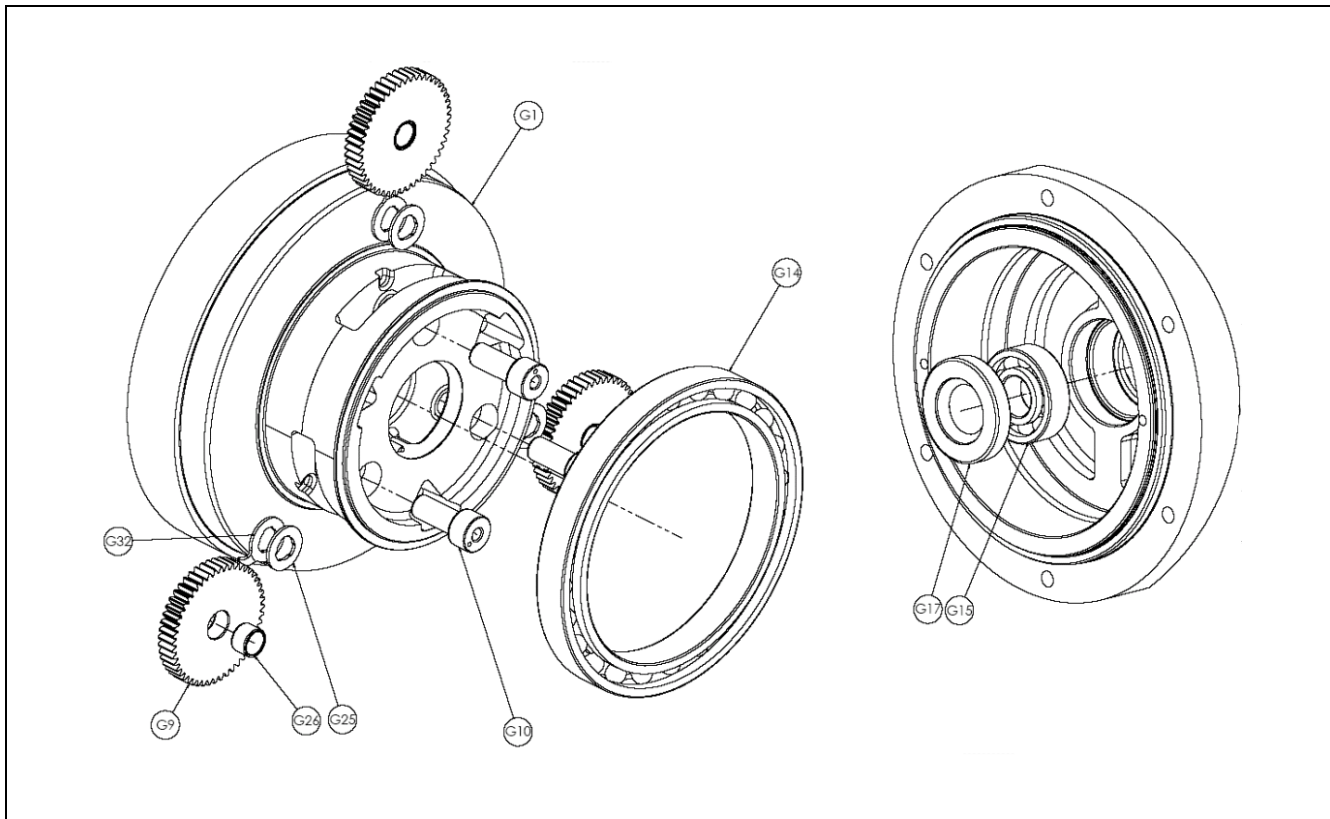

Spindle Disassembly

1. Place Spindle Sub-Assembly on bench with **Planet Gears (G9)** facing up.

NOTE: Do not damage or scratch the seal surface of the **Spindle (G1)** during disassembly.

2. Remove three **Output Planet Shafts (G10)**.

NOTE: These Planet Shafts are held in with a press fit. Use the tapped hole in the end of the pin in conjunction with a slide hammer or similar tool to remove them.

3. Remove the **Output Planet Gear (G9)**, **Thrust Washer (G25)**, and **Tanged Washer (G32)** out each of gear "window" of the **Spindle (G1)**.

NOTE: The Output Planet Gears (G9) are very similar in size to the Input Planet Gears (5), tag or label the Planet Gears to avoid confusion.

4. Press out **Bushing (G26)** from the bore of each **Planet Gear (G9)**. Bushings cannot be reused when removed

5. Remove the **Main Bearing (G14)** from the outside diameter of the **Spindle (G1)**.

NOTE: This bearing is held in with a press fit. You will need to pry against the Spindle (1) to remove it. A new bearing should be used when the unit is reassembled.

6. Flip over the **Spindle (G1)**.

7. Press out the **Motor Shaft Seal (G17)** from the center bore. The seal cannot be reused when removed

8. Remove the shaft **Ball Bearing (G15)** from the center bore.

Spindle Sub-Assembly

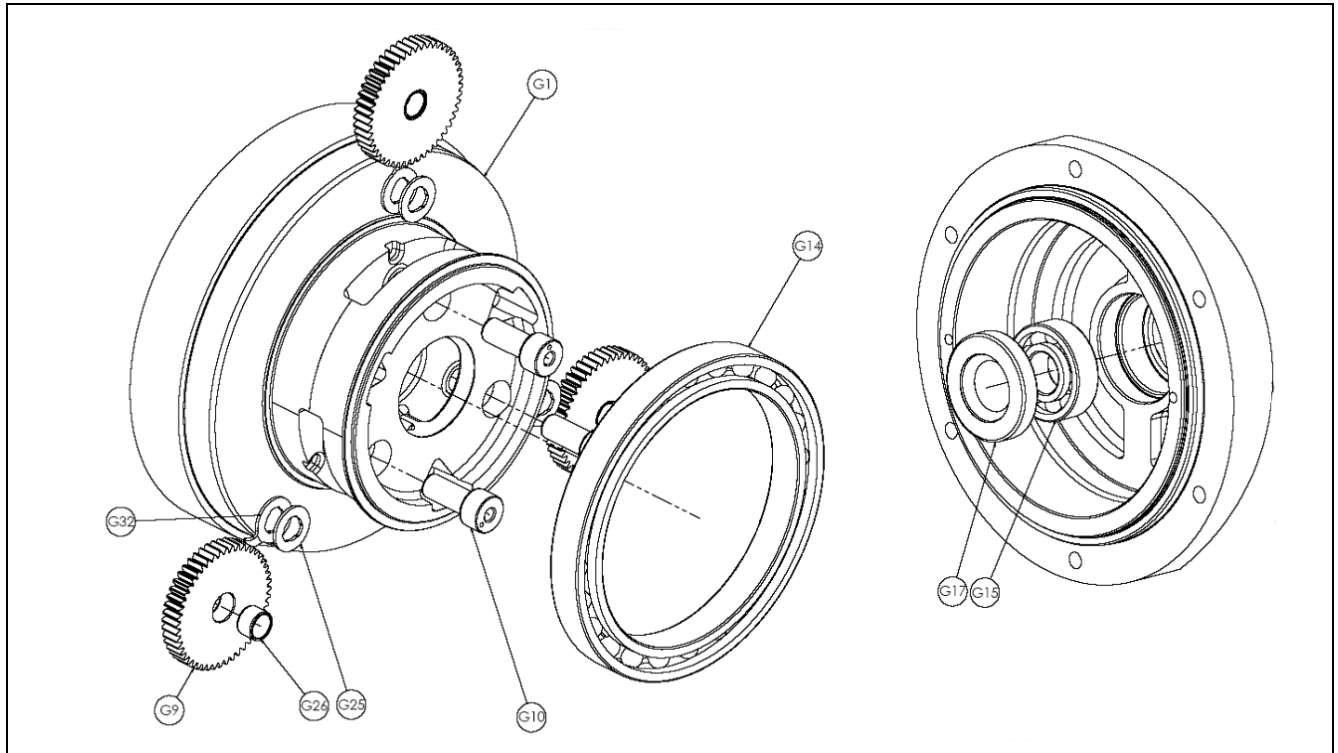

Spindle Sub-Assembly

1. Place the **spindle (G1)** on the bench with the carrier portion facing up.
- NOTE:** Do not damage or scratch the seal surface of the spindle (G1) during assembly.
2. Using the appropriate pressing tool (T-182377), press on **Main Bearing (G14)** until it is fully seated.
 3. Use the **Output Planet Pin (G10)** as a pressing tool to install the **Planet Bushing (G26)** into the bore of each **Planet Gear (G9)**. The shaft will help guide the bushing into the bore as well as prevent damage from the press.
 4. Place **Tanged Thrust Washer (G32)** into each planet "window" of the **Spindle (G1)**. Make sure the tang sits in the cast groove on the inside of the window.
 5. Place a **Thrust Washer (G25)** onto the **Output Planet Gear (G9)**. Line up the bores as best as you can. Use grease to hold the Thrust Washer in place.
 6. Slide the **Output Planet Gear (G9)** into the window with the **Tanged Thrust Washer (G32)** until the bores line up.
 7. Insert **Output Planet Shaft (G10)** into the Planet Shaft hole of the **Spindle (1)** and through the bores of the **Thrust Washers (G25) & (G32)** and the **Planet Gear (G9)**.
 8. Before pressing the **Output Planet Shaft (G10)** into the **Spindle (G1)**, make sure the **Output Planet Gear (G9)** spins freely.
 9. Press the **Output Planet Shaft (G10)** into the **Spindle (G1)** until it bottoms out. Make sure the **Output Planet Gear (G9)** spins freely after the Planet Shaft is pressed in.
 10. Repeat Steps 5-11 for the other two **Output Planet Gears (G9)**.
 11. Turn the **Spindle (G1)** over so that the carrier end is down.
 12. Install **Input Ball Bearing (G15)** into the **Spindle (G1)** bore.
 13. Using a flat plate or rod, press the **Motor Shaft Seal (G17)** into the center bore so that it is flush with the face of the **Spindle (G1)**.

Hub Sub-Assembly

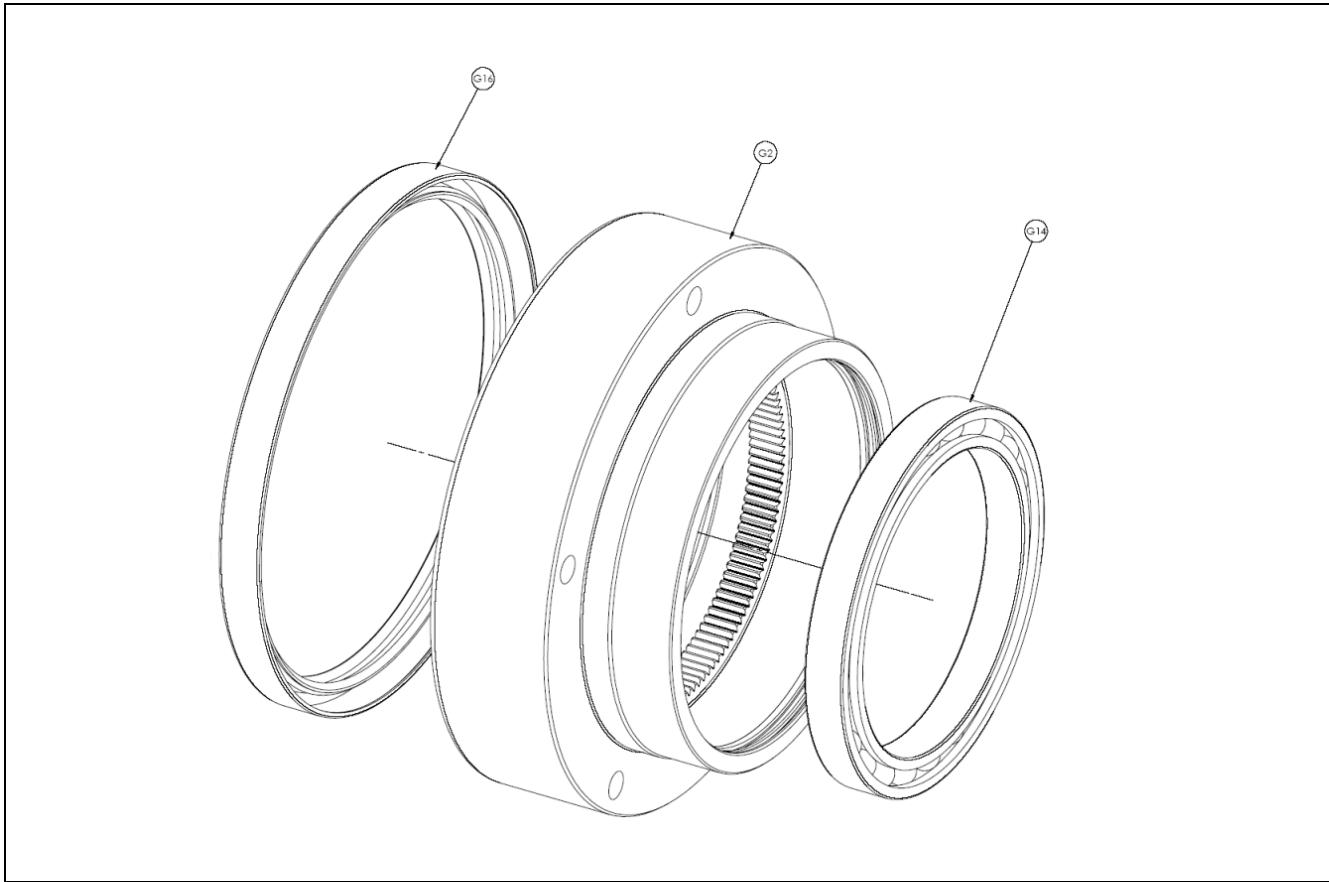

Hub Sub-Assembly

1. Put **Hub (G2)** on a table with the tapped holes facing down.
2. Using a flat plate in conjunction with a pressing tool, press in the **Seal (G16)** so it is flush with the edge of the hub.
3. Flip the **Hub (G2)** over
4. Using the appropriate pressing tool (T-174356), press the **Main Bearing (G14)** into the bore until it bottoms out.

NOTE: *NOTE: The Seal has a thin outer shell that can be easily damaged if not installed with care. It is a good idea to start the Seal into the bore with a rubber mallet before pressing.*

Input Carrier Sub-Assembly

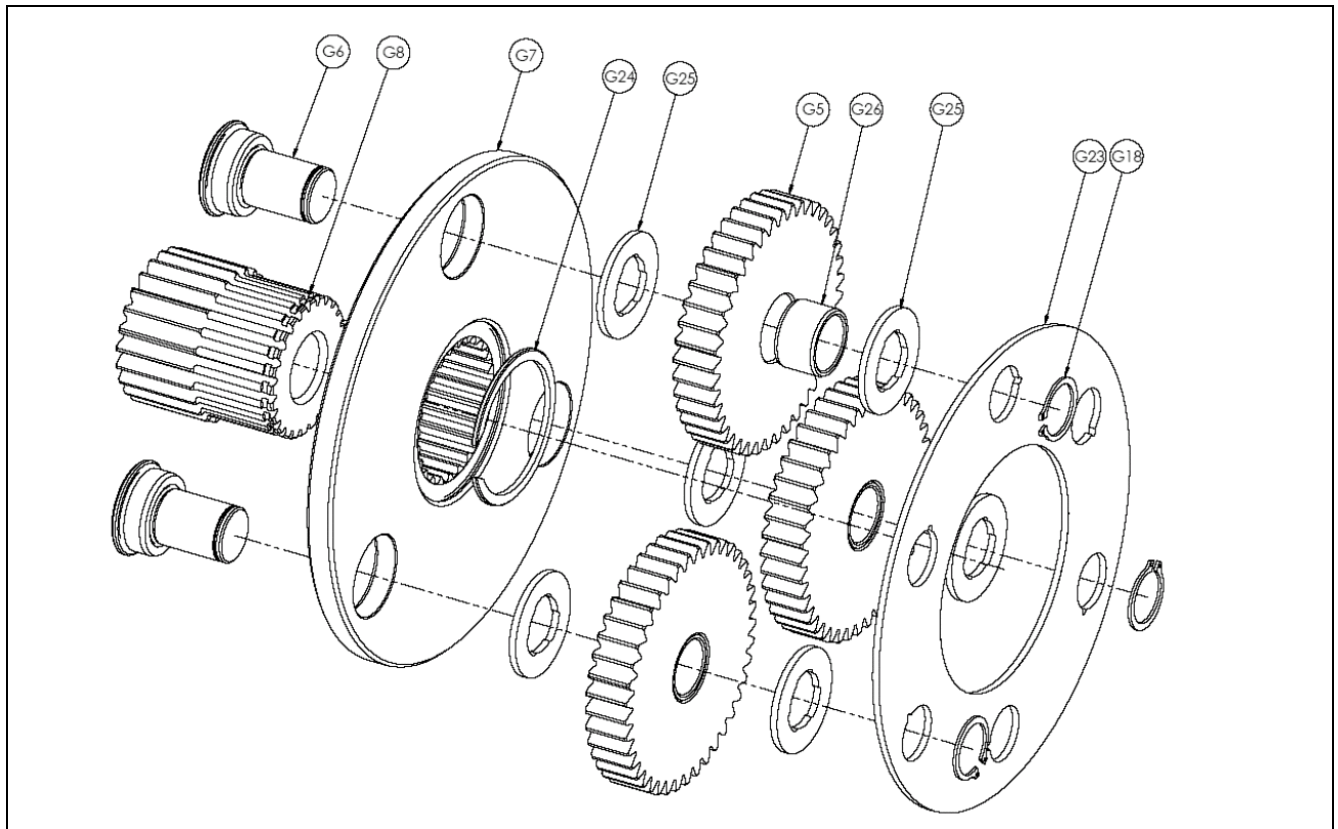

Input Carrier Sub-Assembly

1. Use the **Input Planet Shaft (G6)** as a pressing tool to install the **Planet Bushing (G26)** into the bore of each **Planet Gear (G5)**. The shaft will help guide the bushing into the bore as well as prevent damage from the press.
2. Press three **Input Planet Shafts (G6)** into the three holes of the **Input Carrier (7)**. The head of the **Input Planet Shaft (G6)** needs to sit flush in the counter bore of the **Input Carrier (G7)** holes
3. Insert **Output Sun Gear (G8)** into the splined bore of the **Input Carrier (G7)**. The gear tooth end of the **Output Sun Gear (G8)** should protrude in the opposite direction of the **Input Planet Shafts (G6)**.
4. Using retaining ring pliers, install the **Retaining Ring (G24)** into the groove of the **Output Sun Gear (G8)**. Make sure that the **Retaining Ring (G24)** is correctly seated in the groove and that the **Output Sun Gear (G8)** cannot be pulled out of the **Input Carrier (G7)**.
5. Place a **Thrust Washer (G25)** on each side of the **Input Planet Gear (5)**. Line up the bores as well as you can visually.
6. Place the **Input Planet Gear (G5)** and **Thrust Washers (G25)** onto the **Input Planet Shaft (G6)** sticking out from the **Input Carrier (G7)**.
7. Repeat 5 & 6 for the other 2 **Planet Gears (G5)**.
8. Put the **Thrust Plate (G23)** onto the three **Input Planet Shafts (G6)**. Use the three holes on the outermost bolt circle. The other three holes are for a different gear ratio.
9. Using the appropriate retaining ring pliers put a **Retaining Ring (G18)** into the groove of each **Input Planet Shaft (G6)**.

NOTE: NOTE: Do not overstress the Retaining Rings (G18).

Main Gear Box Sub-Assembly

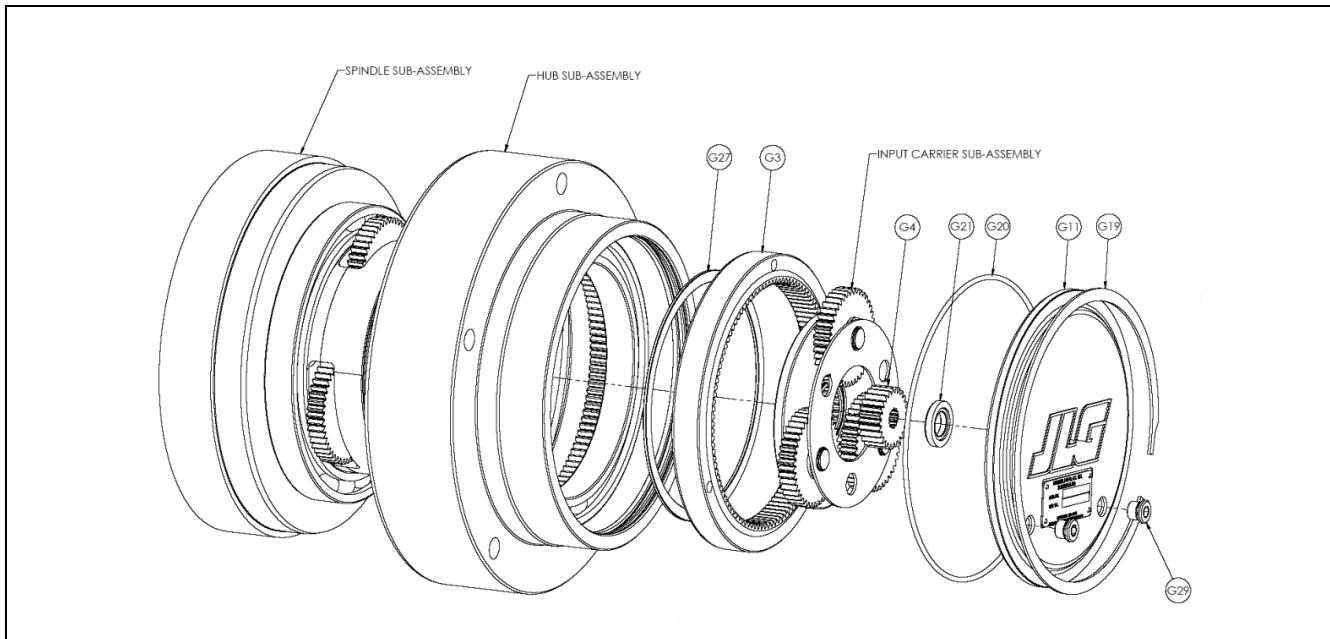

Main Gear Box Sub-Assembly

1. Inspect seal surface of **Spindle Sub-Assembly**. Remove any debris or burrs that may be present.
2. Apply a coating of grease to the Lip Seal (not shown) in the **Hub Sub-Assembly**.
3. Place **Spindle (G1)** Sub-Assembly on table with carrier side up.
4. Carefully install the **Hub Subassembly** (seal side down) onto the **Spindle Sub-Assembly**. This installation should be a slip fit and takes place in 3 stages.

Stage 1: The hub slides together until the gear teeth of the hub hit the gear teeth of the 3 **Output Planet Gears (G9)**.

Stage 2: Find the **Output Planet Gear (G9)** that is tight and turn it until you feel it go into mesh with the hub gear teeth, apply slight downward pressure to the hub and then find the next gear that is tight and do the same.

Stage 3: Once all the **Output Planet Gears (G9)** are in mesh apply pressure to the hub, it should push on the rest of the way.
5. Install **Retaining Ring (G27)** into the groove on the OD of the **Spindle (G1)** carrier. This is a Spiral Retaining Ring so it will not require pliers. You will need to pull the **Retaining Ring (G27)** apart and work it into the groove.
6. Using the appropriate pressing tool (T-174356), press in the **Input Ring Gear (G3)** into the bore of Hub Subassembly.

NOTE: Do not use excessive pressing force because it will be reacted by the main wheel bearings.

7. Install the **Input Carrier Subassembly** into mesh. The **Output Sun Gear (G8)** portion of the **Input Carrier Subassembly** will mesh with the **Output Planet Gears (G9)** and the **Input Planet Gears (G5)** mounted on the **Input Carrier Subassembly** will mesh with the **Input Ring Gear (G3)**.
8. Install the **Input Sun Gear (G4)** into the area between the three **Input Planet Gears (G5)**.
9. Apply a coating of grease to the **Cover O-ring (G20)** and install it into the o-ring groove of the **Hub Subassembly**.

NOTE: It may be helpful to stretch the o-ring (G20) out prior to assembly to avoid pinching or shearing when the Cover (G11) is assembled.

10. Apply Loctite 380 or 480 glue to **Cover Thrust Washer (G21)** and place it in the center counter bore of the Cover (G11) so that the steel face of the washer is out of the bore.

NOTE: Make sure that both the Cover Thrust Washer (G21) and the Cover (G11) have good clean surfaces for the Loctite to properly adhere.

11. Center the **Cover (G11)** in the hub bore so that the "JLG" logo is up. Push it into the bore.
12. Install the **Cover Retaining Ring (G19)** into the groove of the **Hub Sub-assembly**.

Motor, Brake and Gear Box Assembly

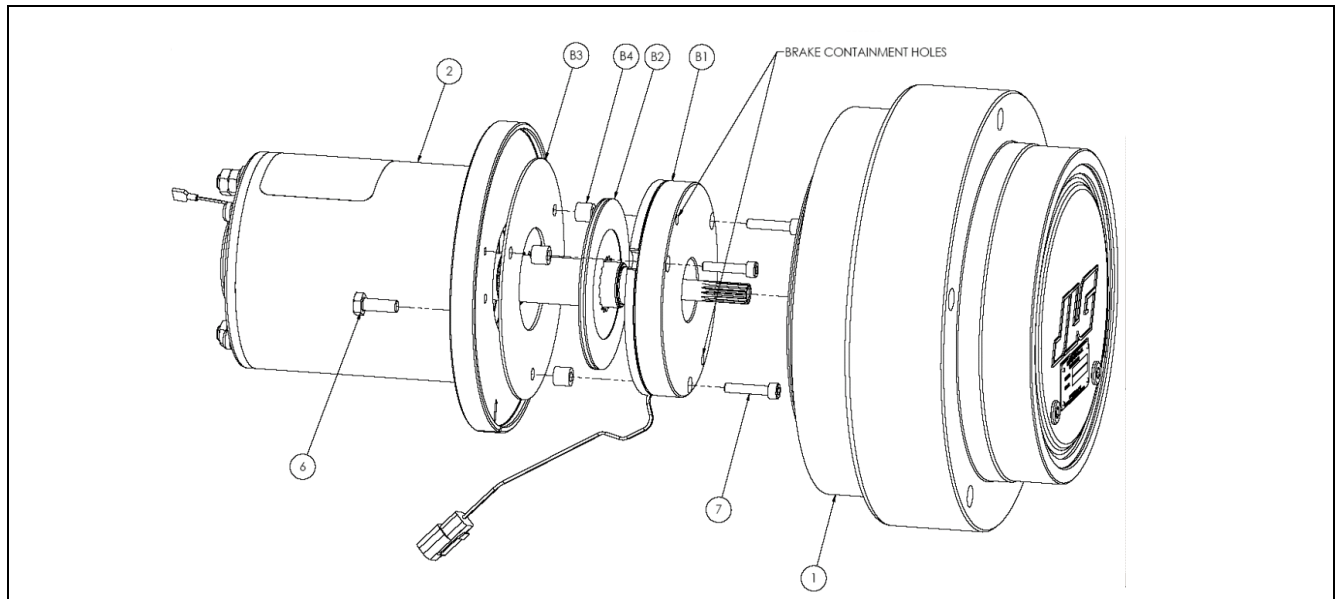

Motor, Brake and Gear Box Assembly

1. Place the **Motor (2)** shaft up on the bench.
2. Place the **Brake Friction Plate (B3)** onto face of the motor flange. Line up the three holes of the **Brake Friction Plate (B3)** with the tapped holes in the motor flange.
3. Place the **Brake Disc (B2)** on the motor shaft. Make sure the splines are properly lined up and the **Brake Disc (B2)** is down against the **Brake Friction Plate (B3)**.
4. Place the three **Spacers (B4)** so that they line up with the three holes in the **Brake Friction Plate (B3)**.
5. Carefully place the **Brake Housing (B1)** onto the **Spacers (B4)** so that the holes in the **Brake Housing (B1)** line up with the holes in the **Spacers (B4)**. Make sure that the wire leads coming out of the **Brake Housing (B1)** are lined up with the slot in the motor flange.
6. Install the three **Brake Bolts (7)** into the three holes in the **Brake Housing (B1)**. Tighten to 4-5 ft-lbs.
7. Remove and discard the 2 bolts in the **Brake Containment Holes**.
8. Pull the Brake Lead through the through the slot in the motor flange. Make sure the leads are all the way in the bottom of the slot.
9. Install a wire tie around the brake leads and the motor housing. Position the wire tie so that it is approximately 2" back from the motor flange.
10. If the **Gearbox (1)** is loose from the machine place it onto the bench with the cover side down. If the **Gearbox (1)** is attached to the machine, perform the next step with extreme caution.

NOTICE

WHEN MOUNTING THE BRAKE FRICTION PLATE TO THE MOTOR FLANGE, CHECK THAT THE MOTOR HOUSING TO FLANGE MOUNTING BOLTS ARE NOT CONTACTING THE BRAKE FRICTION PLATE UNDERNEATH. CONTACT INTERFERENCE COULD CAUSE THE BRAKE FRICTION PLATE TO WARP WHEN TIGHTENED DOWN.

3. Place the **Brake Disc (B2)** on the motor shaft. Make sure the splines are properly lined up and the **Brake Disc (B2)** is down against the **Brake Friction Plate (B3)**.
4. Place the three **Spacers (B4)** so that they line up with the three holes in the **Brake Friction Plate (B3)**.
5. Carefully place the **Brake Housing (B1)** onto the **Spacers (B4)** so that the holes in the **Brake Housing (B1)** line up with the holes in the **Spacers (B4)**. Make sure that the wire leads coming out of the **Brake Housing (B1)** are lined up with the slot in the motor flange.
6. Install the three **Brake Bolts (7)** into the three holes in the **Brake Housing (B1)**. Tighten to 4-5 ft-lbs.
7. Remove and discard the 2 bolts in the **Brake Containment Holes**.

NOTICE

BEFORE MOUNTING THE DRIVE MOTOR/BRAKE ASSEMBLY TO THE GEARBOX SPINDLE HUB BE CERTAIN THE BRAKE CAVITY INSIDE THE GEARBOX IS CLEAN AND FREE OF ANY OIL RESIDUE.

11. Slowly slide the **Motor (2)** into the **Gearbox (1)**. Make sure that the end of the motor shaft does not damage the Gearbox (1) lip seal.

NOTE: *The motor may need to be rotated to line up the sun gear splines with the motor shaft splines.*

12. Install the 2 **Motor Bolts (6)**. Tighten to 8-9 ft-lbs.
13. Apply a bead of silicone sealant to the slot in the motor flange where the brake leads are exiting.
14. Fill the **Gearbox (1)** with oil per instructions (See Page 3-4).
15. The wheel drive is now ready to be installed onto the machine, reverse removal instructions (See Page 3-5).

3.6 POT HOLE PROTECTION SYSTEM

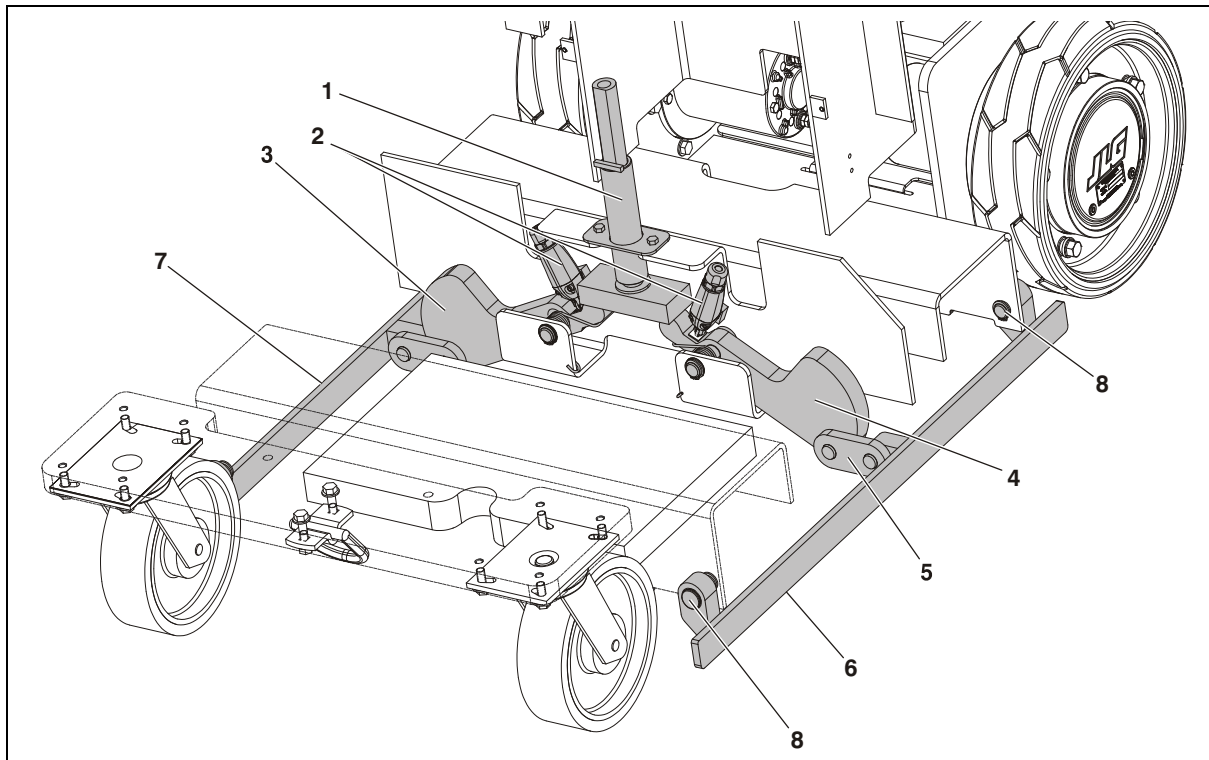

Pot-Hole-Protection System Components

- | | |
|--------------------------------|---|
| 1. PHP Actuator (Platform) | 5. PHP Link (see detail illustration following) |
| 2. Right/Left PHP Limit Switch | 6. Left PHP Bar |
| 3. Right Side Counterbalance | 7. Right PHP Bar |
| 4. Left Side Counterbalance | 8. PHP Bar Pivot Pin and Retaining Ring |

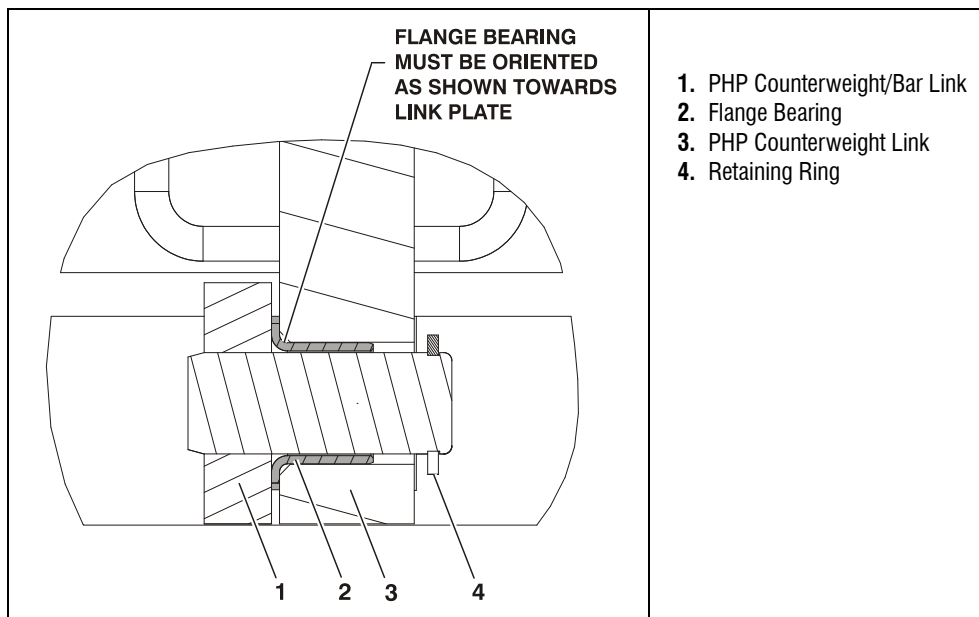

PHP Link Installation (Item 5 in Component Illustration Above)

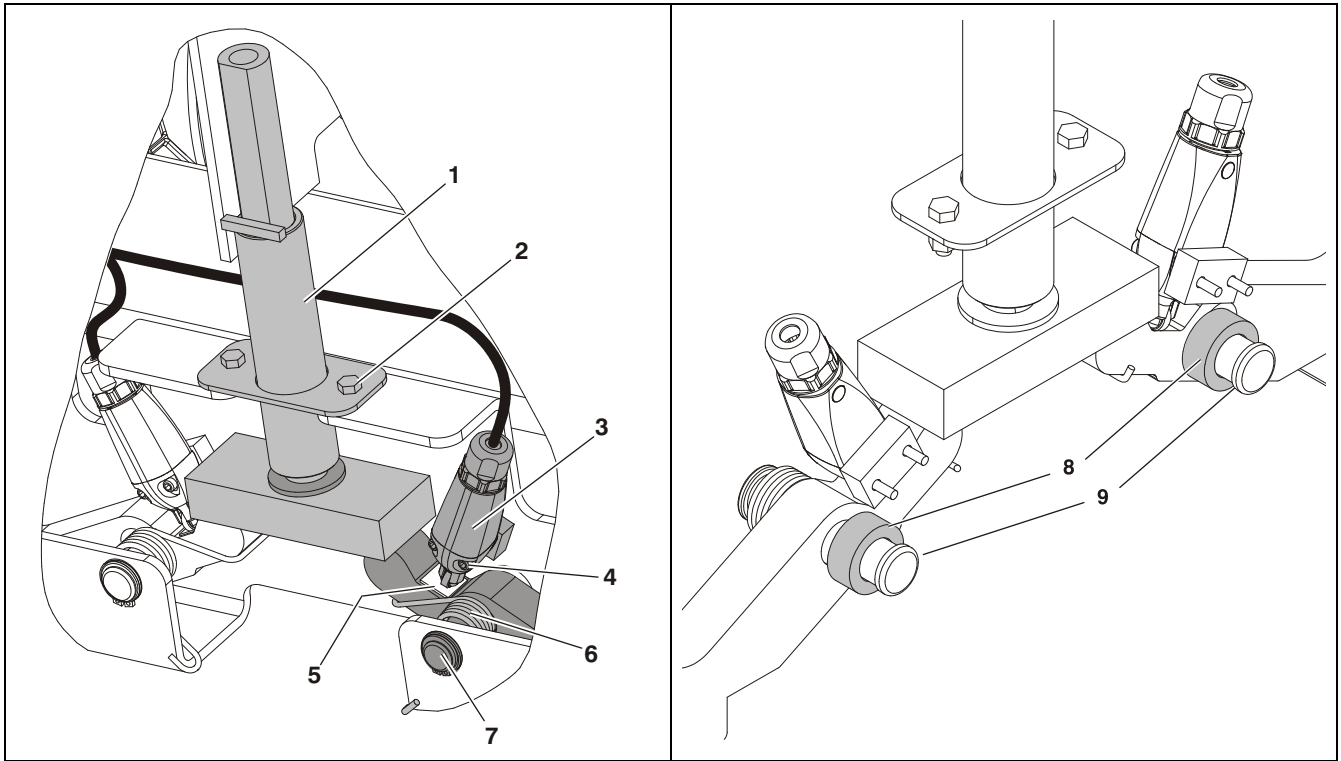

Actuator - Limit Switch - Counterweight Installation - (Machines Prior to S/N-0130013258)
(Same both sides of machine)

- | | |
|--|--------------------------------------|
| 1. PHP Actuator | 6. Left Side Torsion Spring (yellow) |
| 2. Actuator Attach Screw/Nut | 7. Counterweight Attach Pin |
| 3. Limit Switch (a) | 8. Spacer |
| 4. Limit Switch Attach Screws (b) | 9. Pivot Pin and Retaining Ring |
| 5. Shim, Adhesive-Backed (max. 2 per switch) (c) | |

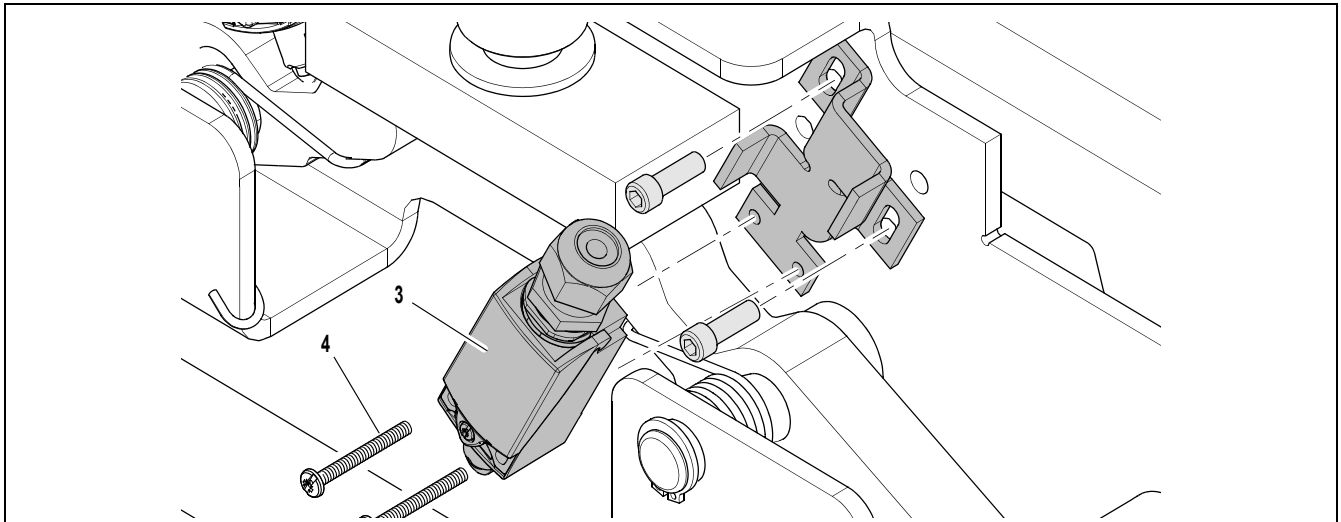

Pot-Hole Switch and Mounting Bracket - (Machines S/N-0130013258 to Present)

- NOTE:** (a) When the pothole is in the deployed position (bars down), adjust plunger just past "click", tighten screws to frame.
 (b) Apply Loctite #222 to screw threads before tightening.
 (c) Add as required if switch is adjusted to maximum and plunger has not clicked to engage switch.

3.7 BATTERY CHARGER - SERVICE PROCEDURES

Battery Charger General Information

NOTICE

DO NOT ATTEMPT TO DISASSEMBLE THE BATTERY CHARGER IF MACHINE IS STILL UNDER WARRANTY. OPENING THE BATTERY CHARGER WHILE THE MACHINE IS UNDER WARRANTY WILL VOID THE CHARGER WARRANTY. IF UNDER WARRANTY REQUEST A REPLACEMENT CHARGER FROM THE FACTORY.

Battery Charger Maintenance Information

1. Make sure charger connections to battery terminals are tight and clean.
2. Do not expose charger to oil or to direct heavy water spraying when cleaning vehicle.

Battery Charge LED Indicator on Platform Control Console

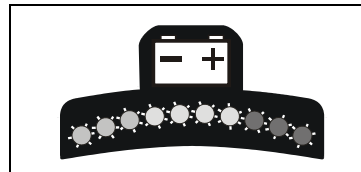

On normal power-up and operation this series of ten (10) LEDs visually indicates the amount of charge remaining in the batteries.

The number of LEDs lit will change depending on the level of charge in the batteries.

- (+) All Three (3) GREEN LEDs lit up indicate maximum battery charge.
- Four (4) YELLOW LEDs indicate a two thirds to one third battery charge remaining.
- (-) Three (3) RED LED's lit indicate minimum battery charge remaining. The machine will continue to operate at this charge level but will begin to indicate battery low voltage warning indicators.

Battery Low Voltage Warning Indicators

The Platform Control Console and Ground Control Station indicate battery low voltage at three (3) Warning Levels. (See Table 3-2. following).

Table 3-2. Battery Low Voltage Warning Indicators.

WARNING LEVEL	INDICATOR LOCATION		RESULT	ACTION REQUIRED TO CLEAR FAULT
	PLATFORM CONTROL LED	GROUND CONTROL LCD		
LEVEL-1			<ul style="list-style-type: none"> • 3 LEDs/BARS Flashing with an audible beep. • Machine will Operate - No Control Functions Locked Out. 	Charge batteries to a level of four (4) LEDs/BARS or more before operating.
LEVEL-2			<ul style="list-style-type: none"> • 2 LEDs/BARS Flashing with an audible beep. • Platform Lift-UP Function is Locked Out. 	Charge batteries for a minimum of four (4) continuous hours or more, or (8) LEDs/BARS lit before operating. (a)
LEVEL-3			<ul style="list-style-type: none"> • 1 LED/BAR Flashing with an audible beep. • Drive and Platform Lift-UP Functions Locked Out. 	Charge batteries for a minimum of four (4) continuous hours or more, or (8) LEDs/BARS lit before operating. (a)

NOTE: (a) To maximize battery life, it is recommended that the factory supplied batteries be charged continuously for a minimum of 4 hours or until 8 bars are lit on the ground station LCD Display before operating the machine. When drained to Warning Level 2, batteries must be charged until 8 bars are lit on the ground station LCD display to clear the fault code.

Battery Charging Status Indicators

The battery charging status indicators are located just above the Charger AC input receptacle on the center cover section at the rear of the machine. This LED indicator set is plugged directly into a connector on the back of the battery charger and indicates current charging status.

When first plugged in, the charger will automatically turn on and go through a short LED indicator self-test (all LED's will flash in an up-down sequence for two seconds), then charging will begin.

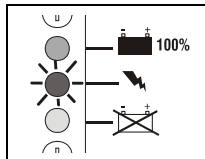

CHARGING

YELLOW(MIDDLE) LED ON
Charge Incomplete

1. The YELLOW 'CHARGING' LED will turn on and a trickle current will be applied until a minimum voltage is reached.

Once a minimum battery voltage of 2 volts per cell is detected, the charger will enter the bulk charging constant-current stage and the YELLOW 'CHARGING' LED will remain on. The length of charge time will vary by how large and how depleted the battery pack is, the input voltage (the higher, the better), and ambient temperatures (the lower, the better). If the input AC voltage is low (below 104VAC), then the charging power will be reduced to avoid high input currents. If the ambient temperature is too high, then the charging power will also be reduced to maintain a maximum internal temperature.

2. When the GREEN 'CHARGED' LED turns on, the batteries are completely charged.

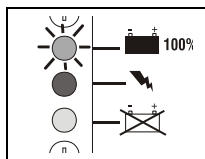

CHARGE COMPLETE

GREEN (TOP) LED ON
100% Complete

The charger may now be unplugged from AC power (always pull on plug and not cord to reduce risk of damage to the cord). If left plugged in, the charger will automatically restart a complete charge cycle if the battery pack voltage drops below a minimum voltage or 30 days has elapsed.

3. If a fault occurred anytime during charging, a fault indication is given by flashing the RED 'FAULT' LED with a code corresponding to the error.

There are several possible conditions that generate errors. Some errors are serious and require human

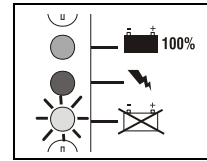

CHARGING PROBLEM

RED (BOTTOM) LED ON
See Flash Codes following

intervention to first resolve the problem and then to reset the charger by interrupting AC power for at least 10 seconds. Others may be simply transient and will automatically recover when the fault condition is eliminated. To indicate which error occurred, the RED 'FAULT' LED will flash a number of times, pause, and then repeat.

[1 FLASH] Battery Voltage High: auto-recover. Indicates a high battery pack voltage.

[2 FLASH] Battery Voltage Low: auto-recover. Indicates either a battery pack failure, battery pack is not connected to charger, or battery volts per cell is less than 0.5 VDC. Check the battery pack and battery pack connections.

[3 FLASH] Charge Time-out: Indicates the battery did not charge within the allowed time. This could occur if the battery is of a larger capacity than the algorithm is intended for. It can also occur if the battery pack is damaged, old, or in poor condition. In unusual cases it could mean charger output is reduced due to high ambient temperature.

[4 FLASH] Check Battery: Indicates the battery pack could not be trickle charged up to the minimum 2 volts per cell level required for the charge to be started. This may also indicate that one or more cells in the battery pack are shorted or damaged.

[5 FLASH] Over-Temperature: auto-recover. Indicates charger has shutdown due to high internal temperature which typically indicates there is not sufficient airflow for cooling – see step 1 of Installation Instructions. Charger will restart and charge to completion if temperature is within accepted limits.

[6 FLASH] Qui-Q Fault: Indicates that the batteries will not accept charge current, or an internal fault has been detected in the charger. This fault will nearly always be set within the first 30 seconds of operation. Once it has been determined that the batteries and connections are not faulty and Fault 6 is again displayed after interrupting AC power for at least 10 seconds, the charger must be brought to a qualified service depot.

Battery Charger Check/Change Charging Algorithm

The charger comes pre-loaded with nine algorithms for batteries as detailed in Table 3-3. If your specific battery model is not listed, please contact JLG.

Each time AC power is applied with the battery pack NOT CONNECTED, the charger enters an algorithm select/display mode for approximately 11 seconds.

During this time, the current Algorithm # is indicated on the YELLOW 'CHARGING' LED. A single digit Algorithm # is indicated by the number of blinks separated by a pause. A two digit Algorithm # is indicated by the number of blinks for the first digit followed by a short pause, then the number of blinks for the second digit followed by a longer pause.

To Check/Change The Charging Algorithm:

1. Disconnect the charger positive connector from battery pack. Apply AC power and after the LED test, the Algorithm # will display for 11 seconds.
2. To change algorithm, touch connector during the 11 second display period to the battery pack's positive terminal for 3 seconds and then remove – the Algorithm # will advance after 3 seconds. Repeat until desired Algorithm # is displayed. A 30 second timeout is extended for every increment. Incrementing beyond last Algorithm moves back to first Algorithm. After desired Algorithm # is displayed, touch the charger connector to the battery positive until the output relay is heard to click (~10 seconds) – algorithm is now in permanent memory.
3. Remove AC power from the charger and reconnect the charger positive connector to the battery pack. It is highly recommended to check a newly changed algorithm by repeating the above steps 1) and 3).

Table 3-3. Battery Charger Algorithm Settings.

ALGORITHM SETTING	BATTERY TYPE
1	Trojan T105
2	Trojan T105 Tapped
3	T105 DV/DT CP
4	US Battery USB2200
5	Trojan 30/31XHS
6	DEKA 8G31 Gel
7	J305 DV/DT CP
8	Concorde 10xAH AGM, Douglas DG12-100M, US BATT 12V100AH AGM, Full River HGL100-12X, Universal Battery UB121000
23	Douglas Flooded (Default)
25	JLG - P/N-0400242
43	Harris Batt. Discover EVGGC6A-A

Battery Charger Removal/Installation

1. Remove the charger cover from the machine located under the platform, see Section 3.2 on page 3-2.
2. Disconnect the positive (+) battery cable at the left side battery under the left rear upper cover.
3. Disconnect the AC input, LED Status Indicator, Drive Cut-Out Interlock, and DC Voltage Output to battery wiring connectors from the top and bottom of the charger assembly.
4. Remove the two (2) screws and washers from the top bracket securing the charger to the frame mount. Only loosen the two (2) screws on the bottom of the bracket of the charger enough to slide the charger out. Move the charger to a suitable work surface.

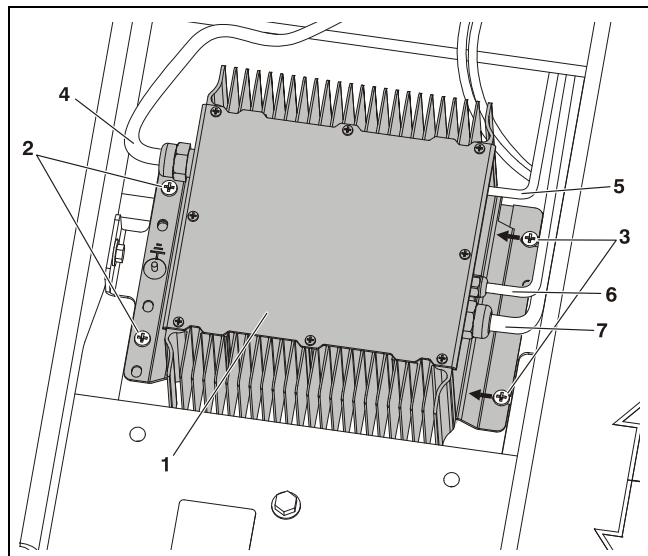

MVL/MSP Battery Charger Removal

1. Battery Charger Assembly
2. Attach Screws (Top)
3. Attach Screws (Bottom) (a)
4. 120/220 AC Voltage Input Cable
5. Charger LED Status Indicator harness
6. Drive Cut-Out Interlock Harness (P2)
7. DC Voltage Output to Battery +/- Posts

NOTE: (a) The mounting bracket is slotted under these screws, loosen only.

SECTION 4. CONTROL COMPONENTS

4.1 CONTROL COMPONENTS OVERVIEW

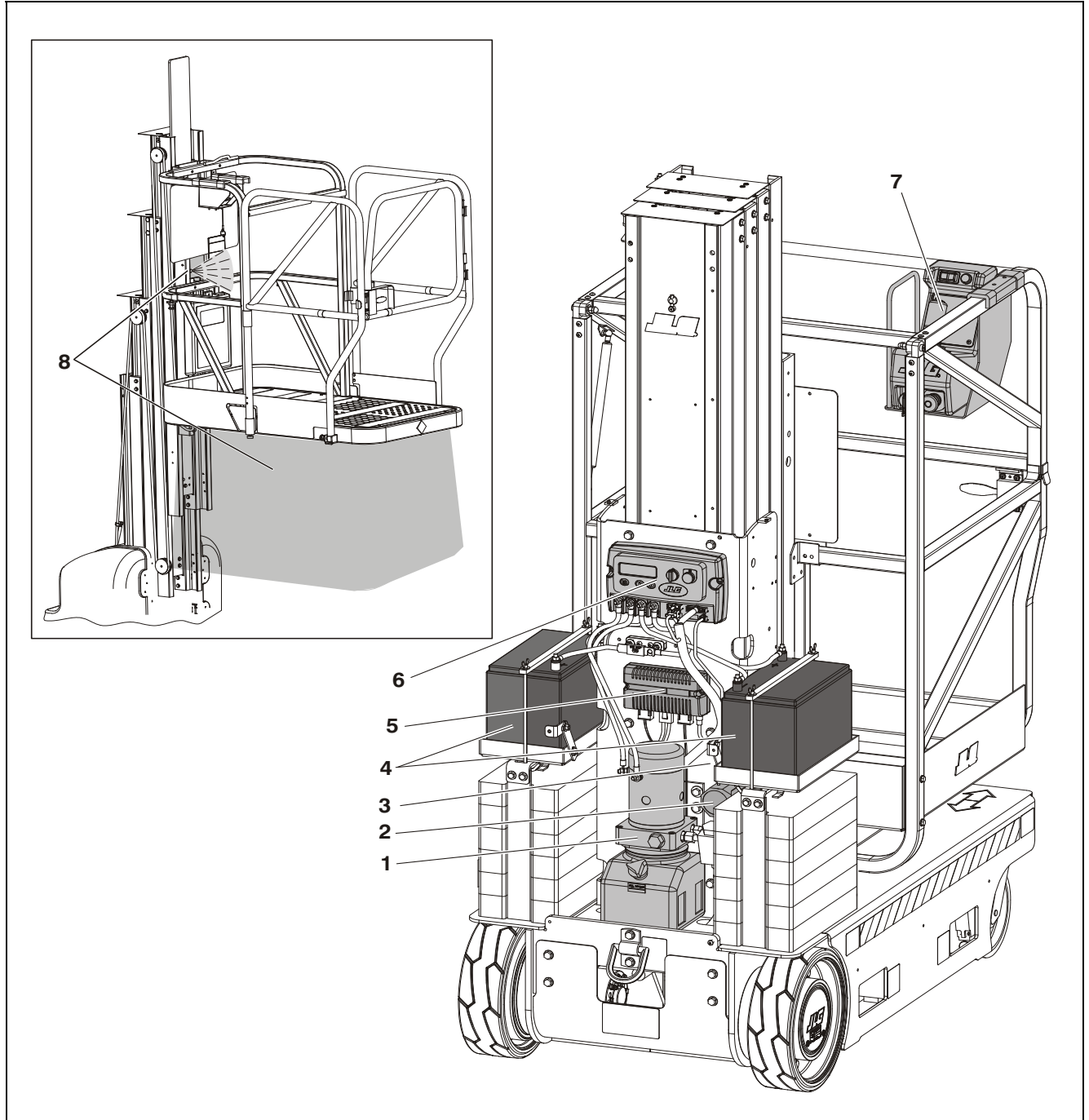

Figure 4-1. Control Components Location - MVL/MSP.

1. Pump/Motor/Tank Assembly
 2. Alarm
 3. Horn

4. Batteries (2-12V - standard)
 5. Traction Control Module
 6. Ground Control Module

7. Platform Control Console
 8. Obstruction Sensor System (MSP - Option)

4.2 CONTROLS COVER INSTALLATION

Battery Cover Doors (Optional Hinged)

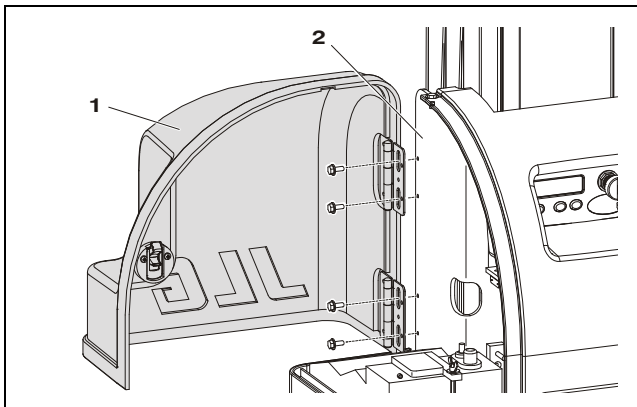

1. Left Side Cover 2. Mast Support Column

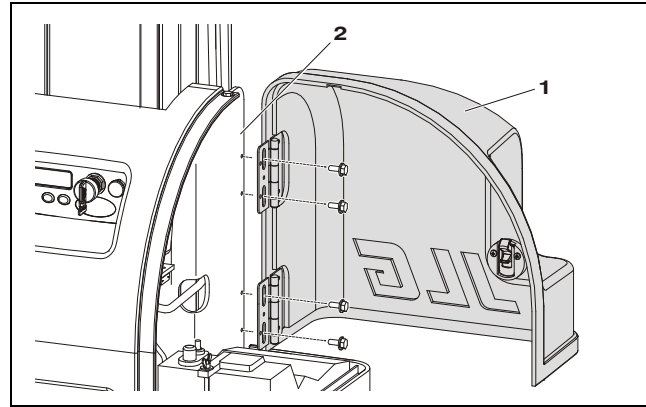

1. Right Side Cover 2. Mast Support Column

Center, Left and Right Lower Covers

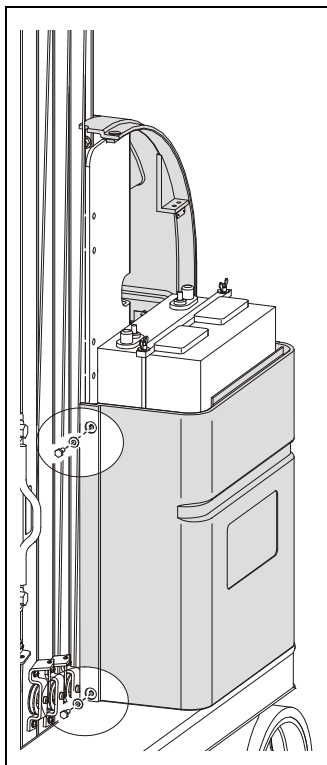

Lower Left Cover (Front View)

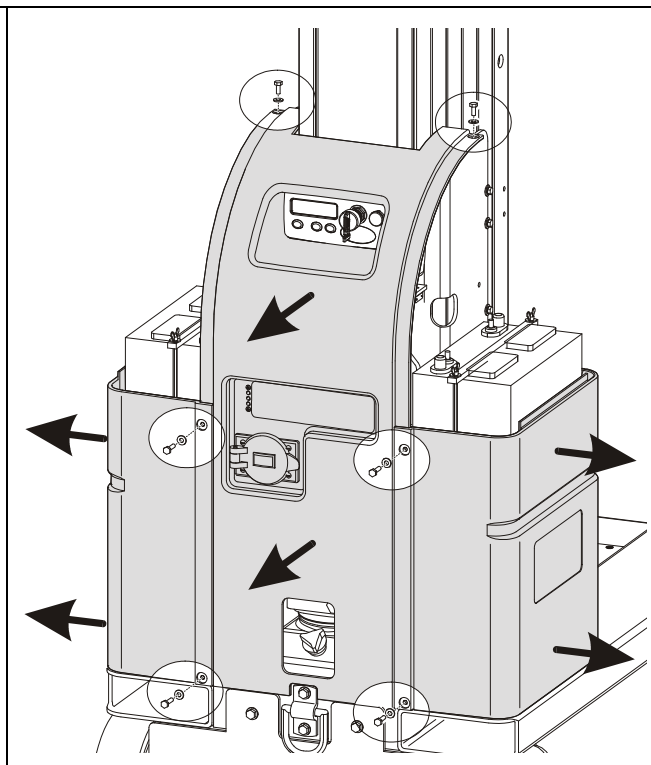

Center Cover, Lower Left and Right Covers (Rear View)

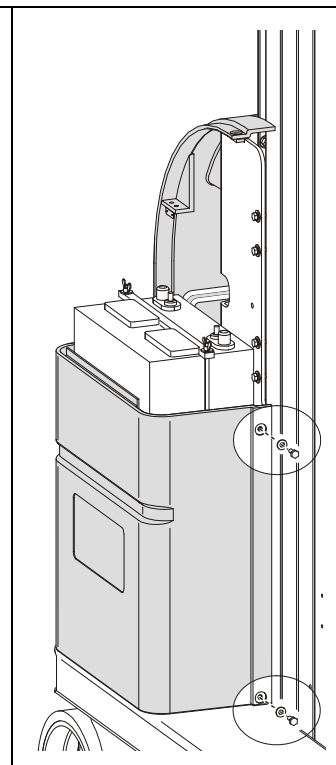

Lower Right Cover (Front View)

Note: Center Cover requires unplugging the Charger AC Receptacle and LED Indicator wires when removing.

4.3 CONTROL COMPONENTS - INSTALLATION

NOTICE

BEFORE REMOVING ANY COMPONENT FROM THE ELECTRICAL SYSTEM, DISCONNECT THE POSITIVE TERMINAL FROM THE LEFT SIDE BATTERY.

Ground Control Module

The Ground Control Module is located under the center cover at the rear of the machine and is mounted on the mast support column. All electrical components on the machine operate directly or indirectly through the Ground Control Module. The module is currently programmed at the factory with the machines operating profile. If replacing a Ground Control Module the new module may require some programming to enable any optional equipment. See Section 4.6, Ground Control Module - Programming.

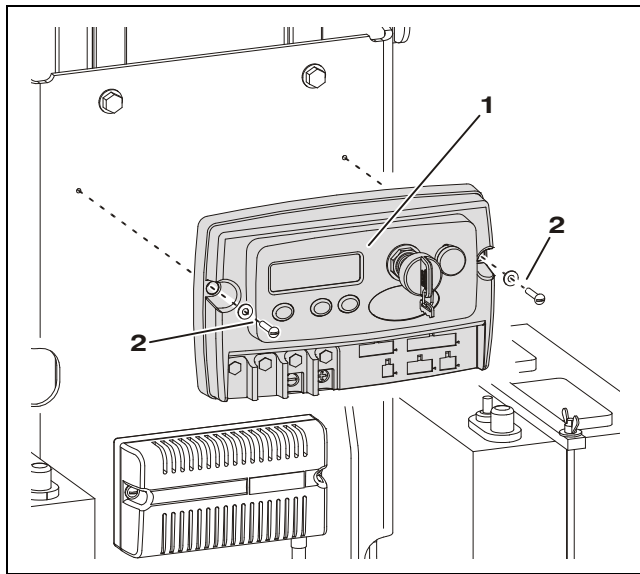

Ground Control Module Installation

- 1. Ground Control Module
- 2. Attach Screws/Washers

Note: See Figure 4-2. for wiring connection instructions.

Traction Control Module

The Traction Control Module is mounted below the Ground Control Module on the mast support column.

The traction module controls the voltage to the drive motors as regulated by the ground control module, from signals received via the joystick controller located on the platform control module.

There are no internal parts serviced on this module.

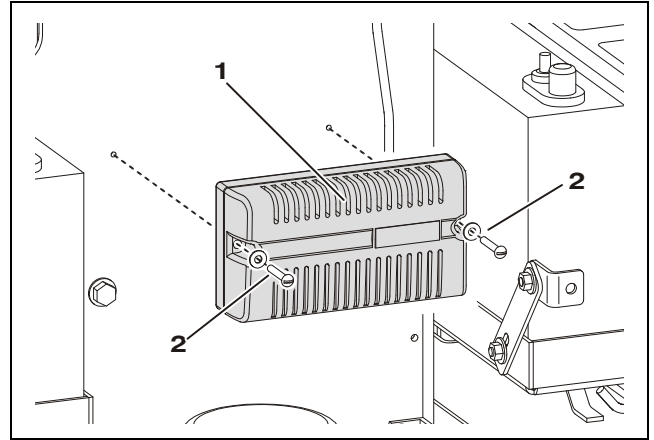

Traction Control Module Installation

- 1. Traction Control Module
- 2. Attach Screws/Washers

Note: See Figure 4-2. for wiring connection instructions.

SECTION 4 - CONTROL COMPONENTS

Platform Control Console Installation

The platform control console is located in the platform and mounted on the right side platform rail.

For removal see below, for servicing information see Section 4.7, Platform Control Console - Service Procedures.

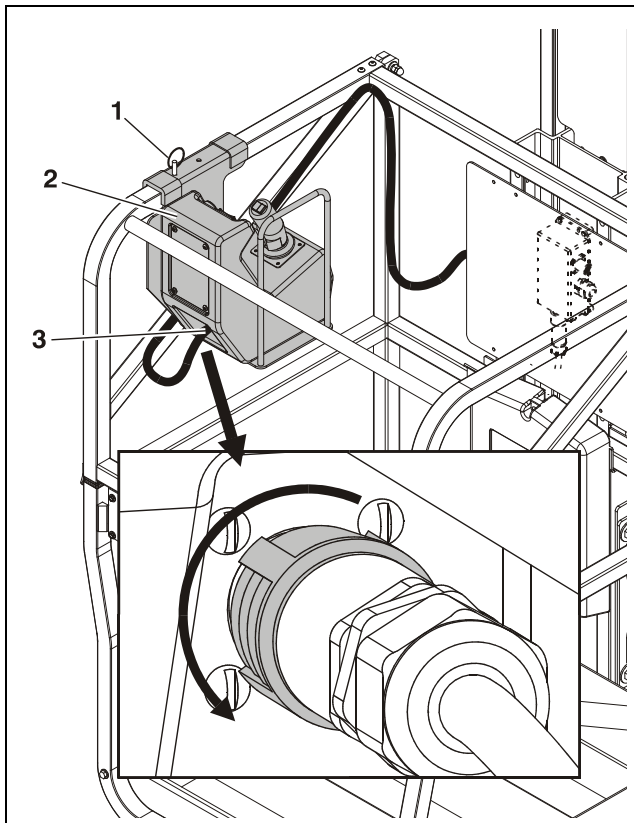

Platform Control Console - Installation

1. Console Mounting Bracket and Attach Pin
2. Platform Control Console
3. Platform Console to Junction Box Harness (a)

Note: (a) The other end of this harness is plugged into the platform junction box mounted to the mast behind the platform decal board. From the console the harness is tie strapped to the platform rail, and run inside the mast through a large hole in the mast to the platform junction box.

Horn Installation

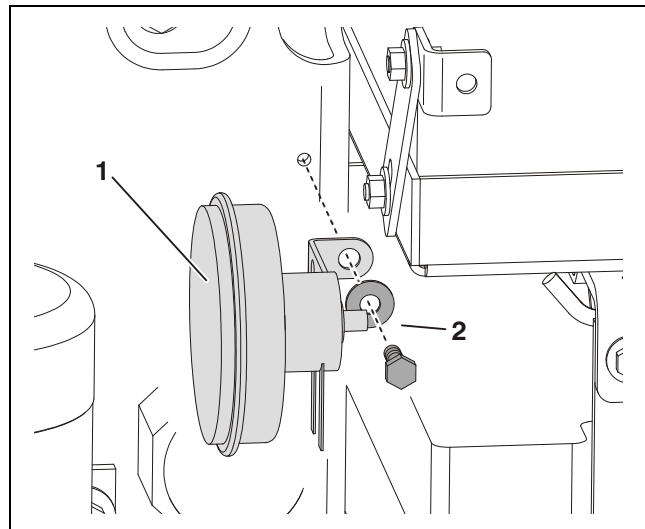

Horn Installation

1. Horn Assembly
2. Attach Screws/Washers

Note: See Figure 4-2. for wiring connection instructions.

Alarm Installation

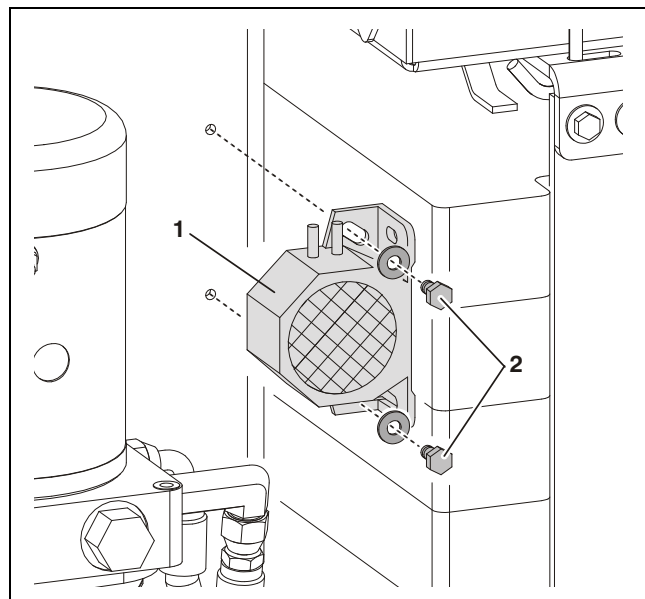

Alarm Installation

1. Alarm Assembly
2. Attach Screws/Washers

Note: See Figure 4-2. for wiring connection instructions.

4.4 BATTERIES - SERVICE PROCEDURES

Battery Replacement

NOTICE

JLG MACHINES EQUIPPED WITH DELTA-Q BATTERY CHARGERS ARE DESIGNED FOR THE BEST PERFORMANCE WITH OEM FACTORY APPROVED BATTERIES.

APPROVED JLG REPLACEMENT BATTERIES ARE AVAILABLE THROUGH JLG'S AFTERMARKET PARTS DISTRIBUTION CENTERS OR JLG'S AFTERMARKET PROGRAMS. FOR ASSISTANCE WITH PROPER BATTERY REPLACEMENT, PLEASE CONTACT YOUR LOCAL JLG SUPPORT OFFICE.

BATTERIES APPROVED BY JLG HAVE BEEN TESTED FOR COMPATIBILITY WITH THE ALGORITHM PROGRAMMING OF THE DELTA Q BATTERY CHARGER TO OPTIMIZE BATTERY LIFE AND MACHINE CYCLE TIMES. THE USE OF NON APPROVED BATTERIES IN YOUR JLG EQUIPMENT MAY RESULT IN PERFORMANCE ISSUES OR BATTERY CHARGER FAULT CODES. JLG ASSUMES NO RESPONSIBILITY FOR SERVICE OR PERFORMANCE ISSUES ARISING FROM THE USE OF NON APPROVED BATTERIES.

Replacement battery(s) must be of equivalent voltage and amperage output as the OEM battery(s) in order for the machine to operate to as manufactured specifications. Battery replacement part weight must also be equivalent to OEM per battery, in order to maintain machine stability as manufactured. (See Section-1 of this manual for battery specifications).

WARNING

DO NOT REPLACE ITEMS CRITICAL TO STABILITY, SUCH AS BATTERIES, WITH ITEMS OF DIFFERENT WEIGHT OR SPECIFICATION. DO NOT MODIFY UNIT IN ANY WAY TO AFFECT STABILITY.

Battery Condition Testing

NOTE: Batteries in storage should be kept at 12.5V or higher.

Before testing for battery condition, the open circuit voltage should be taken from each battery. If the voltage of the batteries differs by 0.3 volts or more, the lower voltage battery should be replaced.

Battery Testing Can Be Performed In Two Ways:

1. The batteries can be tested using a battery tester capable of testing 12V 100Ah AGM VRLA (Valve Regulated Lead Acid) batteries, using the instructions of the battery tester manufacturer.
2. If an appropriate battery tester is unavailable, the batteries can be tested by fully charging them with the charger that is installed on the machine. Then check the battery voltage of each battery - 4 hours - after charging is complete. Batteries less than 12.72 volts should be replaced.

NOTE: If a faulty charger is suspected, the batteries can be charged using a charger that supplies 2.45 volts/cell. Charging should be terminated when the charge current drops below 1 amp.

Battery Disconnect (Option)

If equipped, the optional battery disconnect loop is located on the left side of the mast assembly, just above the rear cover assembly. Battery electrical power to the machine is disconnected when the upper half of the connector is separated from the fixed lower half connector. Use the wire handle provided on the front of the upper half connector to disconnect it from the lower half. A lanyard keeps the upper half attached to the machine when disconnected.

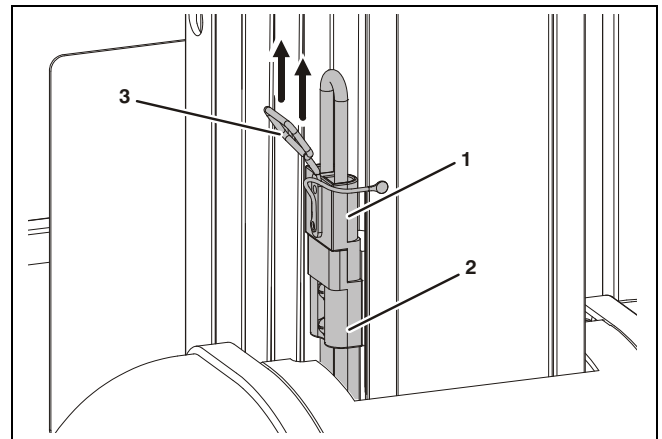

Battery Disconnect (Option)

1. Upper Half of Disconnect
2. Lower Half of Disconnect
3. Upper Half Pull Handle

Battery - Installation - (2-12V Batteries)

To gain access to the batteries, requires opening or removal of the upper half of the rear covers, see Section 4.2, Controls Cover Installation.

Procedure for removal is same for both batteries.

On installation, batteries set in machine with the posts to the inside. Left side battery (-) NEG post at front (shown below), Right side battery (+) POS post towards machine front.

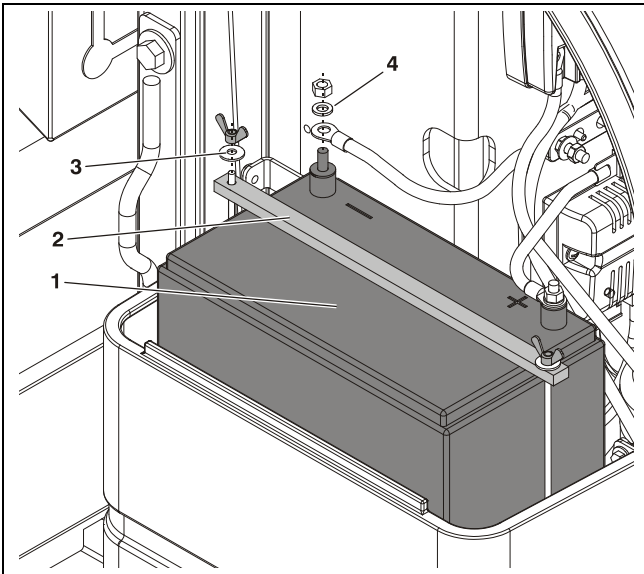

Battery Installation (Left Side Battery Shown)

- | | |
|------------------|---|
| 1. Battery (a) | 3. Battery Terminal Attach Nut/Washer (b) |
| 2. Hold-Down Bar | 4. Hold-Down Bar Wing-nut and Washer |

NOTE: (a) Mount with terminal posts inboard.
(b) Apply battery terminal grease to prevent corrosion.

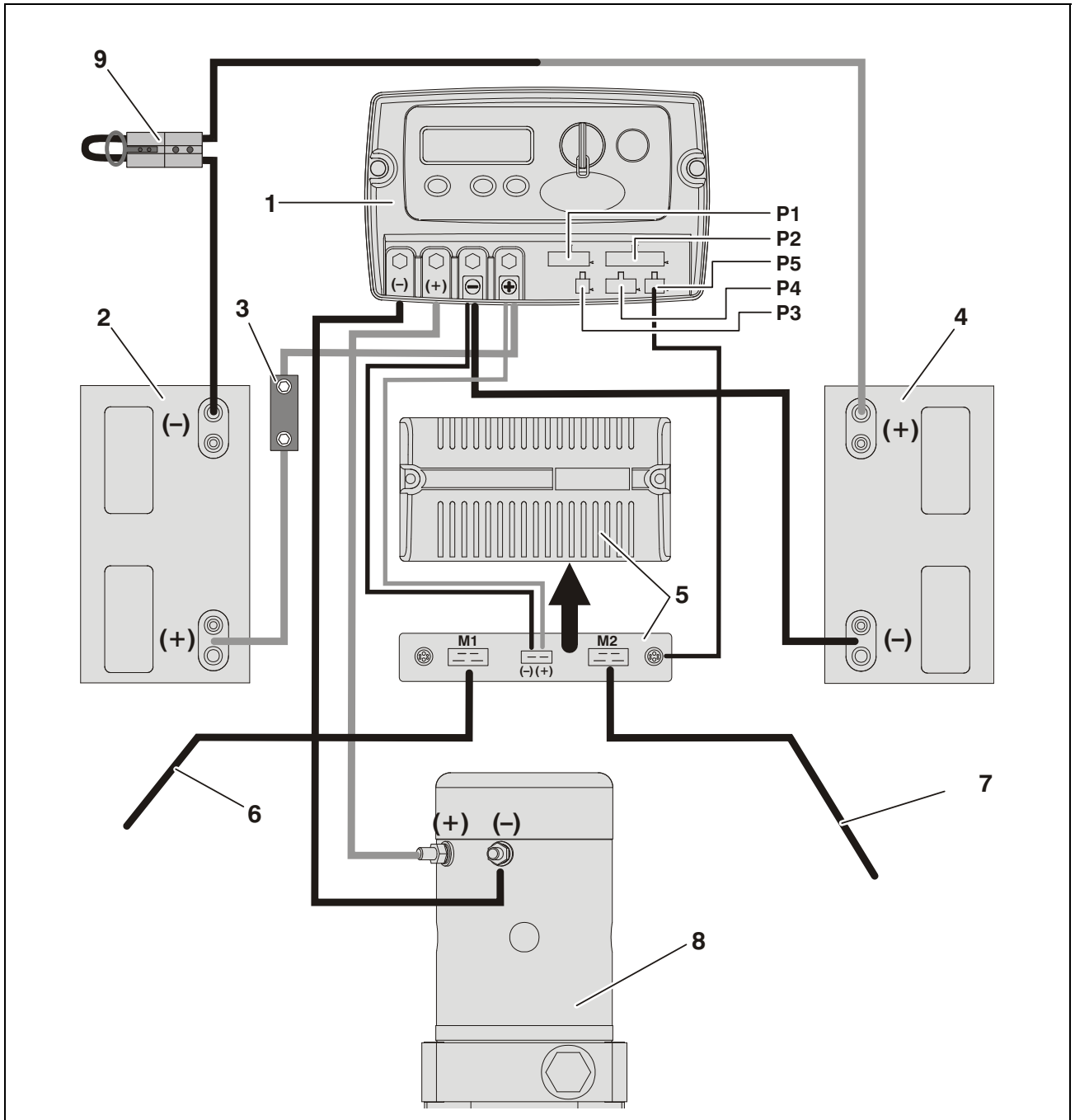

- | | | |
|------------------------------|--|---|
| 1. Ground Control Module (a) | 4. Right Side Battery (b) | 7. Power Cable To Right Drive Motor/Brake (a) |
| 2. Left Side Battery (b) | 5. Traction Control Module (a) | 8. Pump/Motor/Tank Assembly (b) |
| 3. 175 Amp Inline Fuse | 6. Power Cable To Left Drive Motor/Brake (a) | 9. Battery Disconnect (Option) |

Ground Control Module Plugs: P1 - Horn, Alarm, Beacons, Lift Down Valve Harness (a) P4 - Platform Junction Box Harness (a)
 P2 - PHP, Elevation/Speed, Charger Limit Switch Harness (a) P5 - Joystick Protocol Harness (a)
 P3 - Programmable Security Lock Harness (Option) (a)

Notes: (a) Apply di-electric grease JLG Part Number 3020038 to wiring harness terminals, to prevent moisture from entering module.
 (b) Seal NEG (-) and POS (+) posts with battery grease to prevent corrosion.

Figure 4-2. Component Electrical Connections. (2-12V Batteries shown)

Battery Installation - (4-6V Batteries) (OPTION)

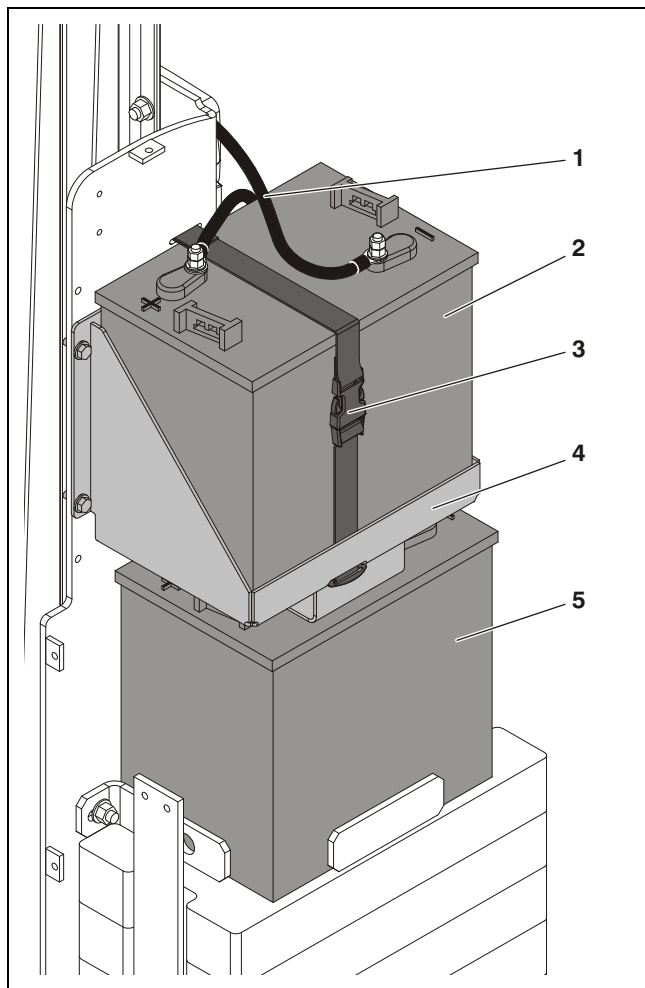

**Battery Installation - 4-6V
(Left Side Batteries Shown with Machine Covers Removed)**

- | | |
|----------------------------------|----------------------------|
| 1. Battery Cables (a)(b) | 4. Upper Left Side Battery |
| 2. Upper Battery | Tray (c) |
| 3. Upper Battery Hold-down Strap | 5. Lower Battery |

NOTE: (a) See battery cable to battery terminal connection illustration - Figure 4-3.
 (b) Apply battery terminal grease to prevent corrosion.
 (c) Three bolts hold the battery tray to the mast support, two shown and one on the back of the support. There is a left side and a right side tray.

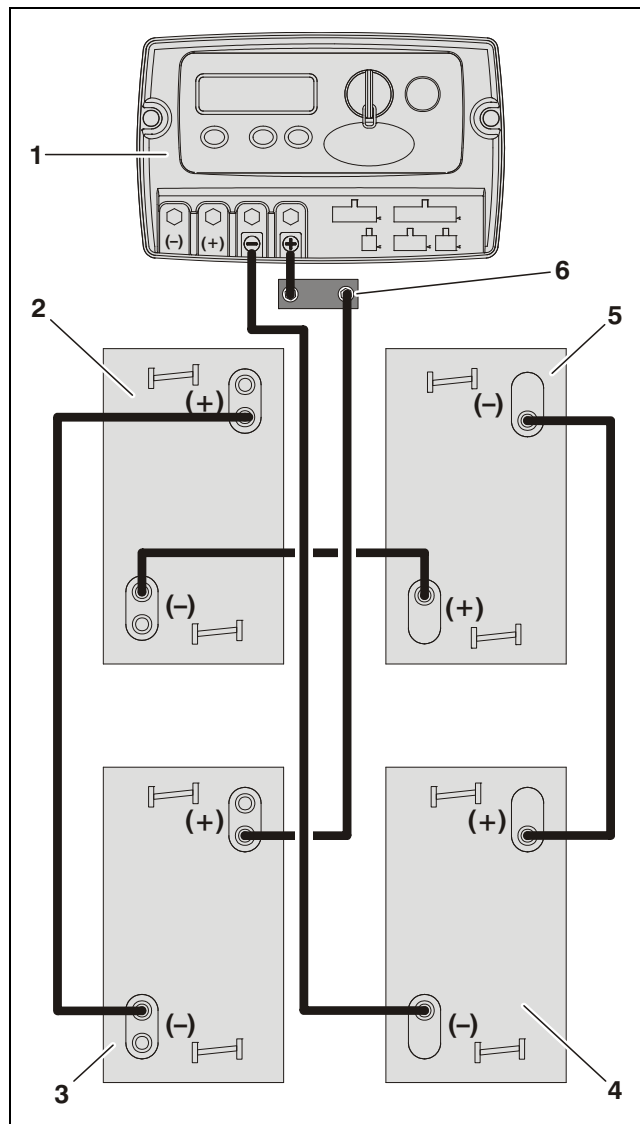

- | | |
|----------------------------|-----------------------------|
| 1. Ground Control Module | 4. Lower Right Side Battery |
| 2. Upper Left Side Battery | 5. Upper Right Side Battery |
| 3. Lower Left Side Battery | 6. 175 Amp Inline Fuse |

NOTE: (a) Label battery cables before removing to ensure proper installation. The battery cables connecting the batteries are identical, only the cable connections to the GCM are different.
 (b) All other connections to Ground Control Module same as in Figure 4-2.

Figure 4-3. Battery Cable to Battery Terminal Connections (4-6V)

4.5 GROUND CONTROL MODULE - SERVICE PROCEDURE

NOTICE

DO NOT ATTEMPT TO DISASSEMBLE THE GROUND CONTROL MODULE IF MACHINE IS STILL UNDER WARRANTY. OPENING THE GROUND CONTROL MODULE WHILE THE MACHINE IS UNDER WARRANTY WILL VOID THE WARRANTY. IF UNDER WARRANTY REQUEST A REPLACEMENT MODULE FROM THE FACTORY.

The MVL Series and MSP Ground Control Module allows for field replacement of two (2) components internal to the module.

- Emergency Stop Switch
- Power Selector Switch (Key)

NOTICE

ELECTROSTATIC DISCHARGE CAN DAMAGE COMPONENTS ON THE INTEGRATED CIRCUIT BOARD. PLACE THE GROUND CONTROL MODULE ON A NON-CONDUCTIVE SURFACE WHEN OPENING.

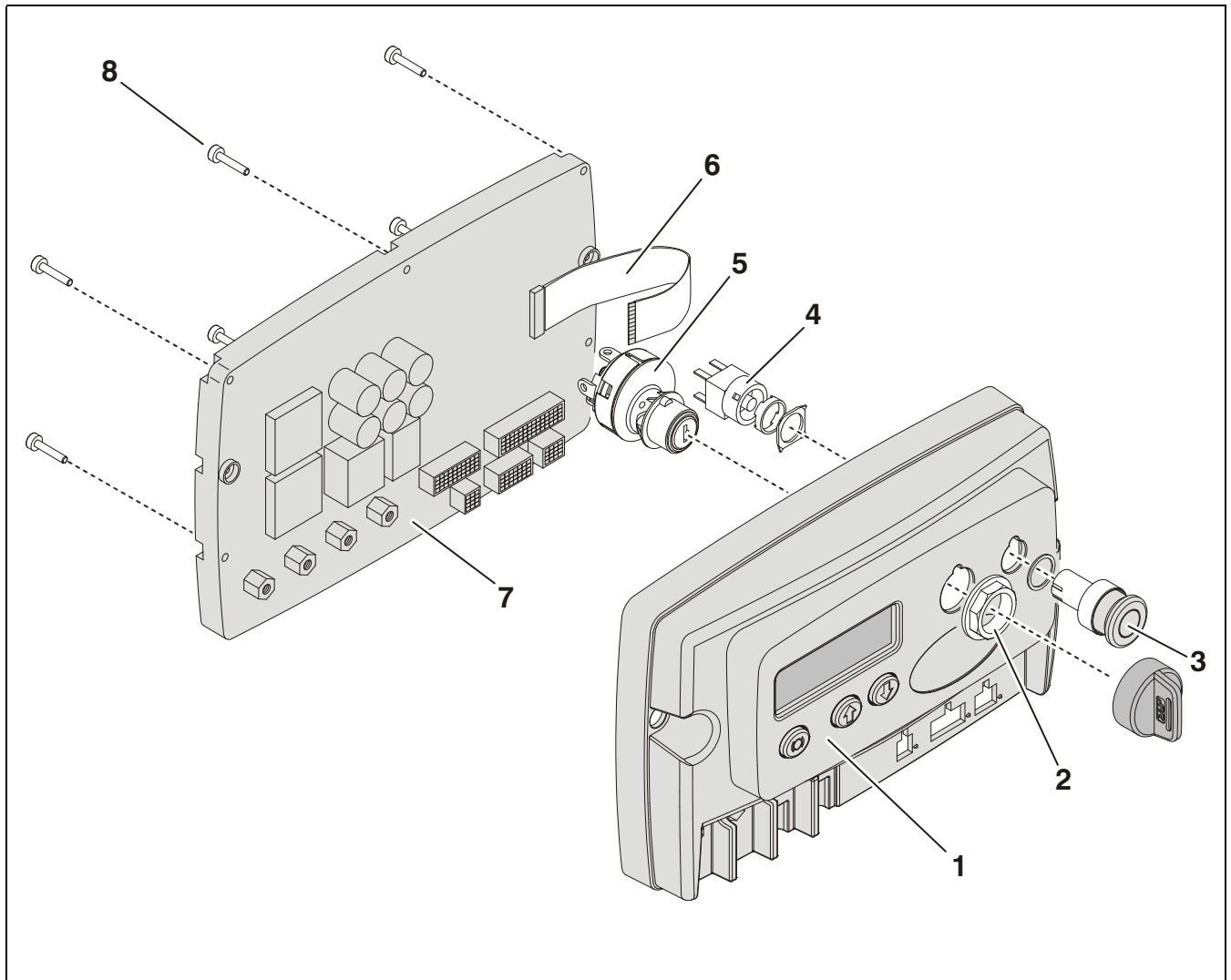

- | | | |
|------------------------------|---|---------------------------------------|
| 1. Cover/LCD Assembly | 4. Emergency Stop Switch | 7. Heat Sink Base/Main Board Assembly |
| 2. Power Selector Switch Nut | 5. Power Selector Switch | 8. Cover Attach Screws |
| 3. Emergency Stop Button | 6. Main Board to LCD Ribbon Cable Connector | |

Figure 4-4. Ground Control Module Components.

Cover Removal/Installation

NOTICE

THE MAIN CIRCUIT BOARD AND THE SMALLER LCD CIRCUIT BOARD MOUNTED TO THE COVER ASSEMBLY, COMMUNICATE THROUGH A RIBBON CABLE. REMOVE THE COVER CAREFULLY ONCE THE COVER SCREWS ARE REMOVED FROM THE BACK OF THE MODULE.

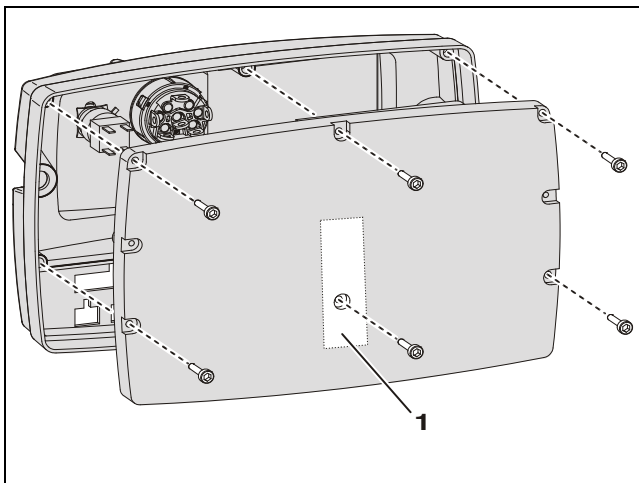

Cover Installation

1. Remove the (6) Hex Socket Screws from the Heat Sink/ Base. One screw is under the Warranty/Tamper Label.

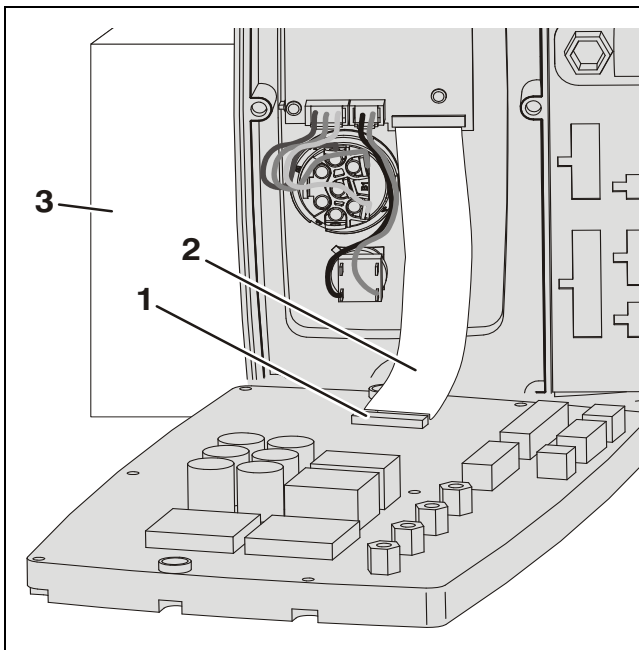

Disconnect the Ribbon Cable

- | | |
|---------------------------|----------------------|
| 1. Ribbon Cable Connector | 3. Support for Cover |
| 2. Ribbon Cable | |

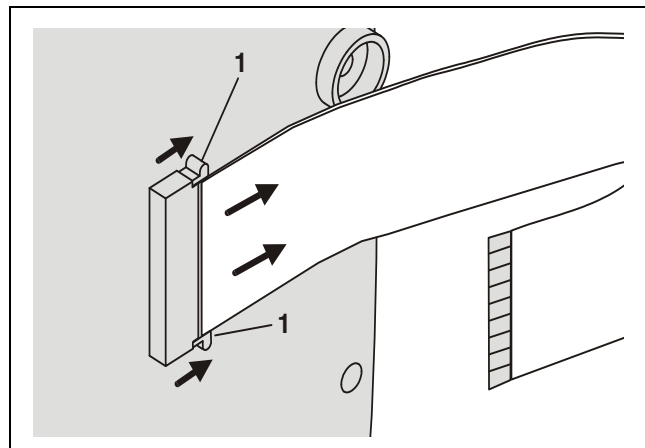

Release Ribbon Cable

1. Ribbon Cable Connector Tabs
(Push tabs away from connector to release cable then slide cable out of connector)

Note: Connector works same at both ends of the ribbon cable.

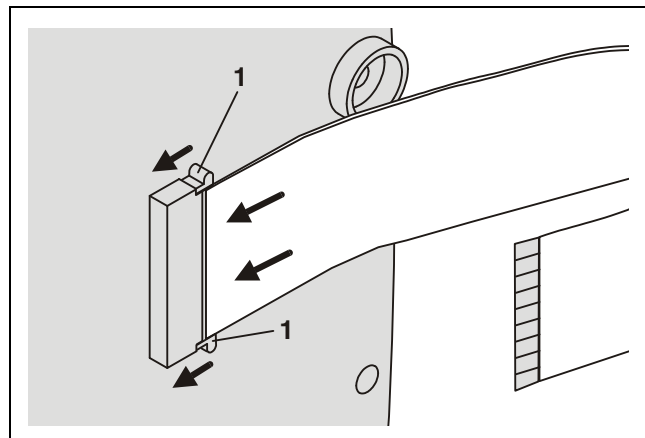

Reconnecting Ribbon Cable

1. Ribbon Cable Connector Release Tabs
(Slide cable into connector then push tabs back into connector)

Note: Connector same at both ends of the ribbon cable.

Power Selector/EStop Switch Installation

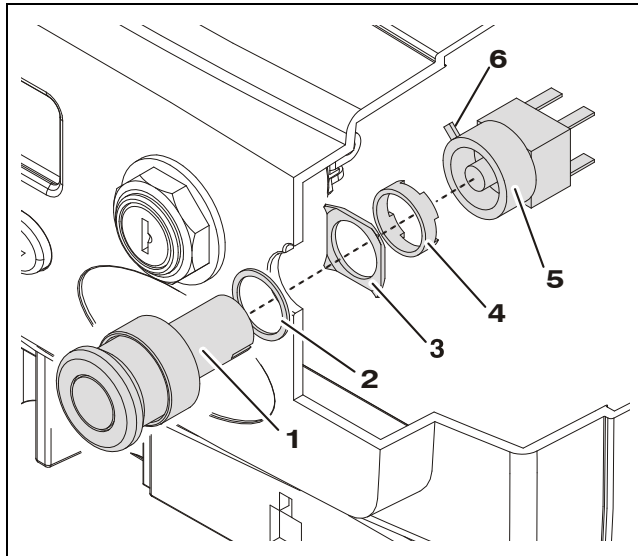

Emergency Stop Switch Installation

- 1. Emergency Stop Button
- 2. Button Seal
- 3. Square Lock Washer
- 4. Nut
- 5. Emergency Stop Switch
- 6. Switch Lock/Release Lever

*Note: Tighten nut enough to keep button from turning.
Reattach wires to same terminals on new switch.*

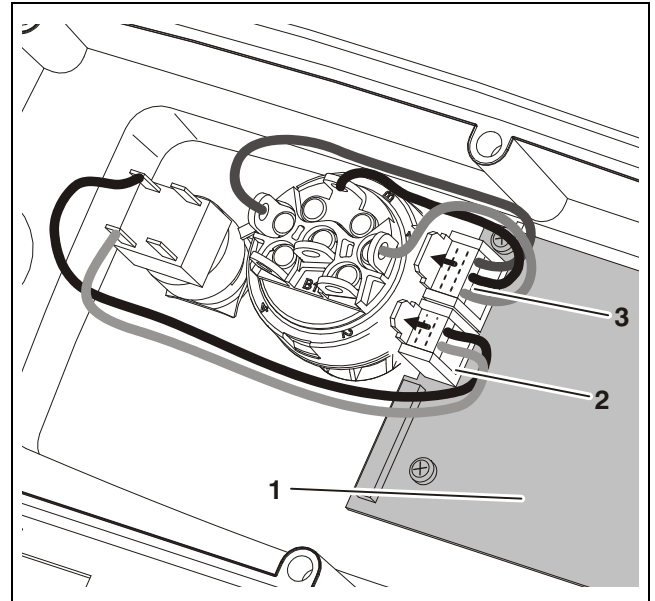

Power Selector/EStop Switch - Connectors Location

- 1. LCD and Button Circuit Board
- 2. Emergency Stop Switch Connector
- 3. Main Power Selector Switch Connector

Note: To release switch connectors, push tab on top of connector.

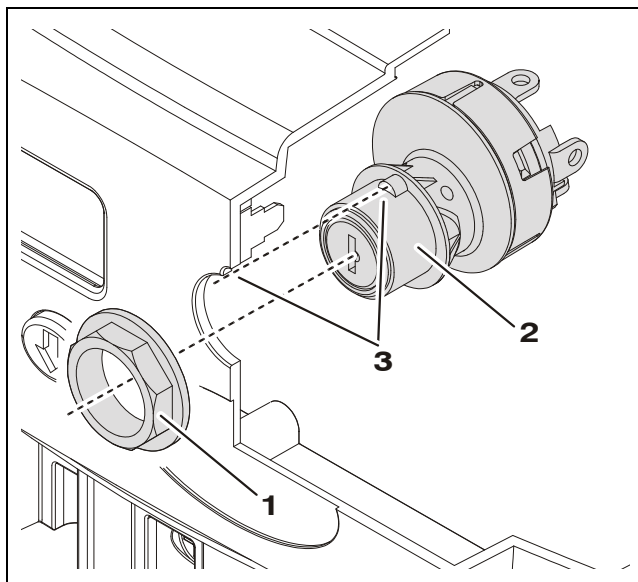

Power Selector Switch Installation

- 1. Nut
- 2. Power Selector Switch
- 3. Align and insert tab on switch into slot on cover.

Note: Re-attach wires to the same terminals on new switch.

4.6 GROUND CONTROL MODULE - PROGRAMMING

General

The MVL/MSP machine Ground Control Module allows on-board programming of various component and control function personality settings.

Programming may be required under circumstances such as:

- Replacement of the Ground Control or Traction Control Module some components or optional equipment may not be enabled under the standard default settings of the replacement unit.
- Optional equipment has been added to the machine in the field and that function must be enabled before operation.
- Customizing the machine to fit a specific application, such as changing the LCD display language, programming operating speeds such as braking, turning or lifting speeds.

Programming Levels

There are three (3) **password protected** programming levels, from highest to lowest, the levels are:

- **Level-1:** JLG Engineering Settings
- **Level-2:** Service and Maintenance Settings -
Level-2 Password: 91101
- **Level-3:** Operator Settings -
Level-3 Password: 33271

NOTICE

THE LEVEL 1 JLG ENGINEERING SETTINGS ARE NOT DISPLAYED IN THE PROGRAMMABLE SETTINGS UNDER PASSWORD LEVEL-2 OR LEVEL-3. LEVEL-1 SETTINGS MUST NOT BE MODIFIED UNLESS DIRECTED BY JLG ENGINEERING DEPARTMENT PERSONNEL.

Level-1: JLG Engineering Settings include voltage, amperage, and ohm output settings that are within the operating parameters of various machine components. This Level can adjust all programmable settings.

Level-2: Service and Maintenance Settings allow modification to machine personality settings such as lift speeds, drive speeds, as well as various switch polarity settings, also enable various optional equipment if installed. This level can also adjust Level-3 settings.

Level-3: Operator Settings allow the direct user to modify a few settings such as the language setting of text output to the Ground Control Module LCD screen, setting machine sleep time, and enabling the detection of the horn and beacon components.

Activating Programming Mode

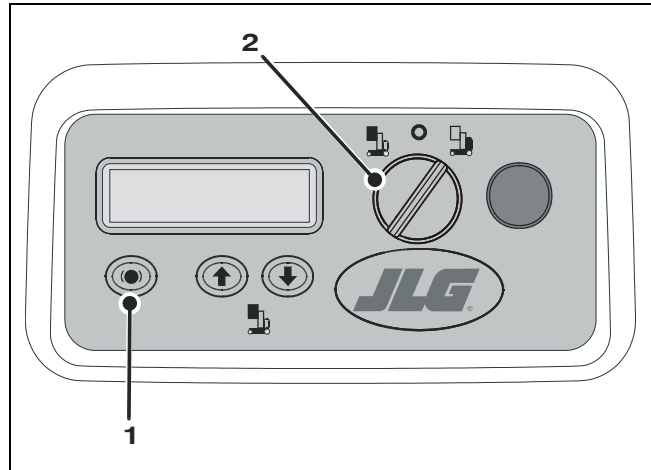

Activating Programming Mode

1. With machine power off, press and hold the Brake Release Button (1) on the Ground Control Module.
2. While holding the Brake Release Button in, power machine up by turning the Main Power Selector Switch (2), to either the Ground Control or Platform Control Mode.
3. Release the Brake Release Button (1) after machine is powered up. The LCD display should now display five zeros, one with a box around. Continue to next step Entering Password.

NOTE: If machine did not power up, check that both the Ground Control Module - Emergency Stop Button, and the Platform Control Console - Emergency Stop Button, are in the RESET position.

Also, if machine is equipped with the (PSL) Programmable Security Lock option, see Section 3 - Programmable Security Lock in your Operators Manual for additional machine power-up steps.

Entering Password

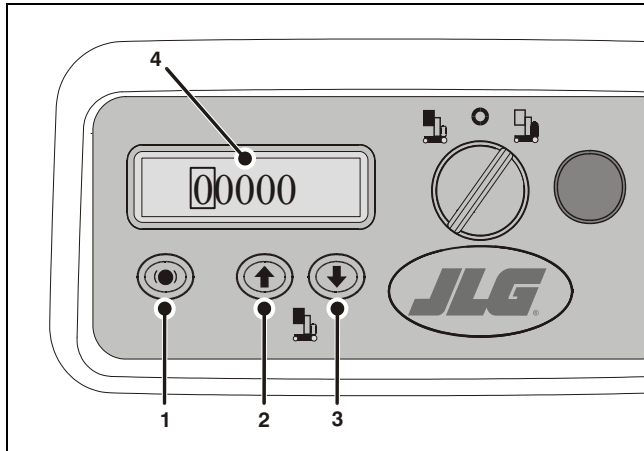

Entering Password

1. The Brake Release button (1) moves the box (around digit) from left to right to select which digit to change.
2. Platform UP button (2) increases the numerical digit.
3. Platform DOWN button (3) decreases the numerical digit.
4. Change all five digits (4) to match password level, then press the Brake Release button (1) again.

Programming Mode Selection

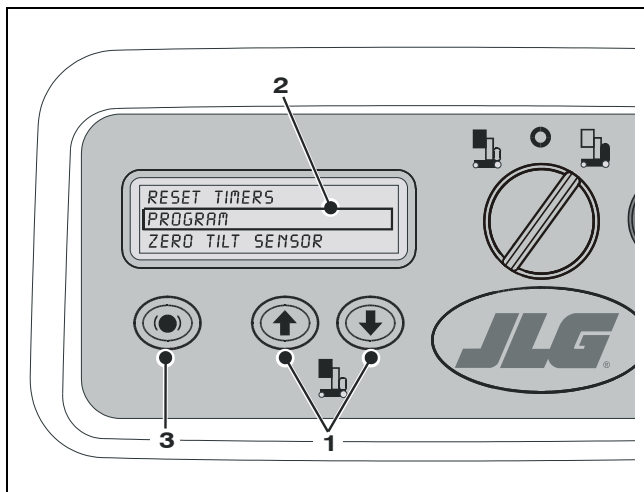

Programming Mode Selection

1. Use Platform UP/DOWN buttons (1) to move the selection box (2) up or down to select item to program.
2. Press the Brake Release button (3) to enter selected mode then move on to Selecting Programmable Item to Adjust.

Selecting Programmable Item to Adjust

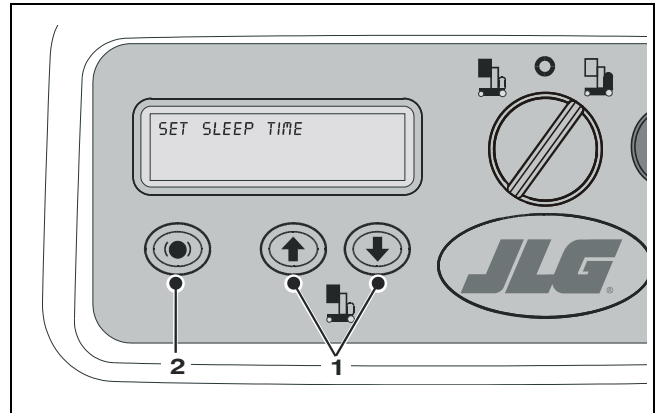

Selecting Programmable Item to Adjust

1. Use the Platform UP/DOWN buttons (1) to scroll through the list of programmable items available to your programming level.
2. Once a programmable item to be adjusted is selected, press the Brake Release button (2) to enter that settings' adjustment mode.

Adjusting Programmable Setting

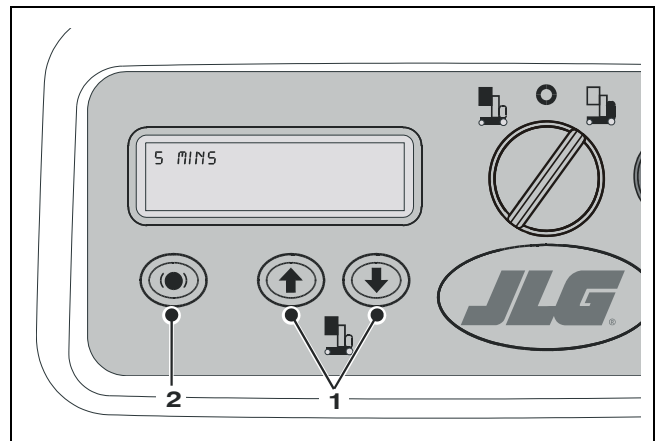

Adjusting Programmable Setting

1. Adjust the programmable setting using the Platform UP/DOWN buttons (1), see Table 4-1 for range of settings for the item selected.
2. Once parameter is set for the programmable item, press the Brake Release button (2), this will enter the parameter and return you to the Programmable Settings Menu.

TO EXIT Programming Mode after entering programmable settings, power machine off with either the Main Power Selector Switch or Emergency Stop Button.

Service Programming Mode - (Level-2)

In the Service Programming Mode the following items are shown on the main menu:

- Reset Timers
- EEPROM Defaults
- Program
- OSS Sensor
- Tilt Sensor

NOTE: There are two production modules available at this time, one for North/South American and European languages, and one for Asian languages. All programmable items between these modules are identical with the exception of language selection.

Reset Timers

This setting displays five (5) timers as described following:

- **Trip Time:** This timer displays total accumulated hours since last trip timer reset. This is the hour meter reading displayed on the Ground Control Module LCD Display during normal machine operation.
- **Traction Time:** Displays the amount of accumulated DRIVE hours on the machine's current drive components.
- **Lift UP Time:** Displays the amount of accumulated time the machine has operated the Lift UP function.
- **Lift DOWN Time:** Displays the amount of accumulated time machine has operated the Lift DOWN function.
- **Total Time:** Displays the total amount of time accumulated by the Traction, Lift UP and Lift DOWN Timers.

Of these five (5) timers, only the Trip Timer can be RESET back to zero (00000.0).

- **Brush Wear Sensor Timer:** This timer must be reset after the drive motor brushes are replaced and the brush wear sensors are repositioned. When reset the display will go from WORN to a blank display. Also the 25 hr./10 second countdown will stop and normal machine operation will resume.

Program

Allows service personnel to program the Level-2 and Level-3 items shown in Table 4-1.

Tilt Sensor

Allows service personnel to reset the Ground Control Module's internal digital Tilt Sensor to zero (0.0) degrees in both the X and Y axis.

⚠ DANGER

ZEROING THE TILT SENSOR REQUIRES THE MACHINE TO BE RESTING ON A SURFACE CHECKED WITH A DIGITAL LEVEL MEASURING WITHIN 0.0 DEGREES LEVEL IN BOTH THE X AND Y AXIS DIRECTIONS.

NOTE: When entering this mode the LCD will display in real time the current X and Y degree readings of the tilt sensor. The reading being displayed is based on the previous zero setting and may not reflect level of the machines current resting surface.

1. Position the machine on a level surface verified level in both the X and Y axis with a digital level.
2. Select "Zero Tilt Sensor" from the menu and press the Brake Release button.
3. The current tilt sensor readings are displayed. To zero both the X and Y direction sensor setting to the machines' present resting surface, press the Brake Release button.
4. Select "Back to Main Menu" and press the Brake Release Button.
5. Power machine off and begin operation.

EEPROM Defaults

Resets programmable settings to factory default settings for 10MSP and 15/20MVL/MSP models.

NOTE: New replacement Ground Control Modules are shipped with the EEPROM Defaults set up for 15/20/MSP/MVL model machines. If a the new replacement module is installed on a 10MSP model, the EEPROM Defaults must be reset to the 10MSP model EEPROM Defaults.

Select "EEPROM Defaults" from the menu and press the Brake Release button. Select the CORRECT machine model, then push Brake Release button to accept. Power machine off and begin operation.

OSS Sensor

Displays current Obstruction Sensor System status (Detection - YES/NO). Also if an object is detected, the sensor(s) detecting the object and distance the object is from the sensor is displayed.

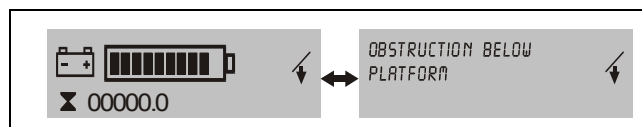

OSS Sensor LCD Display Mode

1. Detection Indicator - Yes/No
2. Sensor numbers
3. Object distance from sensor
4. Signal strength

Note: This screen can be viewed while another person performs the transducer sensor check, see Section 4.9.

Operator Programming Mode - (Level-3)

In the Operator Programming Mode the following items are shown on the main menu (also see Table 4-1):

- Tilt Sensor
- Program

NOTE: There are two production modules available at this time, one for North/South American and European languages, and one for Asian languages. All programmable items between these modules are identical with the exception of language selection.

Tilt Sensor

Allows viewing current tilt sensor individual X and Y direction degree reading.

Program

Allows the Operator to program Level-3 items shown in Table 4-1 following.

Table 4-1. MVL/MSP Ground Control Module - Field Programmable Settings and Factory Preset.

LEVEL	PROGRAMMABLE ITEM	FACTORY PRESET	SETTING RANGE
Level-2: Service Level Settings Level-3: Operator Level Settings		On LCD Display:	YES = ✓ HIGH = ↑ NO = ✗ LOW = ↓
2	Back to Main	15/20MVL/MSP	Return to Programming Menu
3	Set Language <i>NOTE: There are two production modules available, one for North/South American and European Languages, and one for Asian Languages.</i>	1	1 - English 6 - Italian 2 - German 7 - Swedish 3 - Dutch 8 - Brazilian Portuguese 4 - French 9 - Finnish 5 - Spanish
		2	1 - English 3 - Japanese 2 - Chinese
2	Set Maximum Lift Up Speed	100%	0 - 100%
2	Set Maximum Lift Down Speed	100%	0 - 100%
2,3	Set Sleep Time	5 MINS	0 - 60 MINS
2	Set Polarity Of Left Pot Hole Input 1	2	0 - Disabled / 1 - LOW / 2 - HIGH
2	Set Polarity Of Right Pot Hole Input 2	2	0 - Disabled / 1 - LOW / 2 - HIGH
2	Set Polarity Of Up Limit/Elevation Input	HIGH	HIGH/LOW
2	Set Polarity Of Charger Inhibit	LOW	HIGH/LOW
2,3	Set Polarity Of The Keypad Code	LOW	HIGH/LOW
2	Set Polarity Of Ancillary Input 1	LOW (a)	HIGH/LOW
2	Set Polarity Of Ancillary Input 2	LOW (b)	HIGH/LOW
2	Load Sensing (LSS)	OFF	ON/OFF
2,3	Enable Detection Of Horn Open Circuit	NO	YES/NO
2,3	Enable Detection Of Beacon Open Circuit	NO	YES/NO
2	Enable Obstruction Sensor System (OSS)	NO	YES/NO
2	Enable Detection Of Aux. #1 Open Circuit	NO	YES/NO
2	Enable Detection Of Aux #2 Open Circuit	NO	YES/NO
3	Forward Alarm Disable	NO	YES/NO
3	OSS Diagnostic	NO	YES/NO
2	Zero the On-Board Tilt Sensor	NO	YES/NO
3	View Tilt Sensor Readings	—	—
2	Brush Wear Sensor Timer Reset	—	BLANK/WORN
2	Ancillary 1 Input Inhibit	0	0 - 4
2	Ancillary 2 Input Inhibit	0	0 - 4

SECTION 4 - CONTROL COMPONENTS

Table 4-1. MVL/MSP Ground Control Module - Field Programmable Settings and Factory Preset.

Level-2: Service Level Settings		On LCD Display: YES = ✓		HIGH = ↑	
Level-3: Operator Level Settings		NO = ✗		LOW = ↓	
LEVEL	PROGRAMMABLE ITEM	FACTORY PRESET	SETTING RANGE		
2	Ancillary 1 Anti-Tie-down	0	0-1		
2	Ancillary 2 Anti-Tie-down	0	0-1		
2	Mode Select Delay (<i>active before time-out</i>)	5 Sec.	0 - 60 Seconds		
2	Invert Lift Direction	NO	YES/NO		
2	Lift Lock Delay	5 Sec.	0 - 60 Seconds		
2	Acceleration (<i>platform lowered</i>)	80	1 - 100		
2	Deceleration (<i>platform lowered</i>)	80	1 - 100		
2	Turn Acceleration (<i>platform lowered</i>)	50	1 - 100		
2	Turn Deceleration (<i>platform lowered</i>)	50	1 - 100		
2	Maximum Forward Speed (<i>platform lowered</i>)	100	1 - 100		
2	Minimum Forward Speed (<i>platform lowered</i>)	40	1 - 100		
2	Maximum Reverse Speed (<i>platform lowered</i>)	50	1 - 100		
2	Minimum Reverse Speed (<i>platform lowered</i>)	20	1 - 100		
2	Maximum Turn Speed (<i>platform lowered</i>)	20	1 - 100		
2	Minimum Turn Speed (<i>platform lowered</i>)	15	1 - 100		
2	Minimum Forward Speed (<i>platform elevated</i>)	13	1 - 100		
2	Minimum Reverse Speed (<i>platform elevated</i>)	13	1 - 100		
2	Minimum Turn Speed (<i>platform elevated</i>)	5	1 - 100		
2	Motor Compensation	50 mOhms	0 - 500 mOhms		
2	EPPROM Reset	—	Resets GCM to default factory settings		

Notes: (a) MSP Models equipped with stock-picker platform and mid-gate interlock (drive inhibit) switch are factory preset to HIGH.
 (b) MSP Models equipped with 12 ft. or 14 ft. lift-limit-switch option are factory preset to HIGH.

4.7 PLATFORM CONTROL CONSOLE - SERVICE PROCEDURES

General

NOTICE

DO NOT ATTEMPT TO DISASSEMBLE THE PLATFORM CONTROL BOX IF MACHINE IS STILL UNDER WARRANTY. OPENING THE PLATFORM CONTROL BOX WHILE THE MACHINE IS UNDER WARRANTY WILL VOID THE WARRANTY. IF UNDER WARRANTY REQUEST A REPLACEMENT BOX FROM THE FACTORY.

The platform control console allows for replacement of nine (9) components.

- Emergency Stop Switch
- Key Switch
- Joystick Assembly
- Display/Controller Module
- Drive/Lift Mode Selector Switch
- Horn Button Switch
- Rear Cover
- Wiring Harness Connector Socket
- Mounting Bracket

Remove Platform Control Console

First remove the platform control console completely from the platform assembly. See Section 4.3, Control Components - Installation.

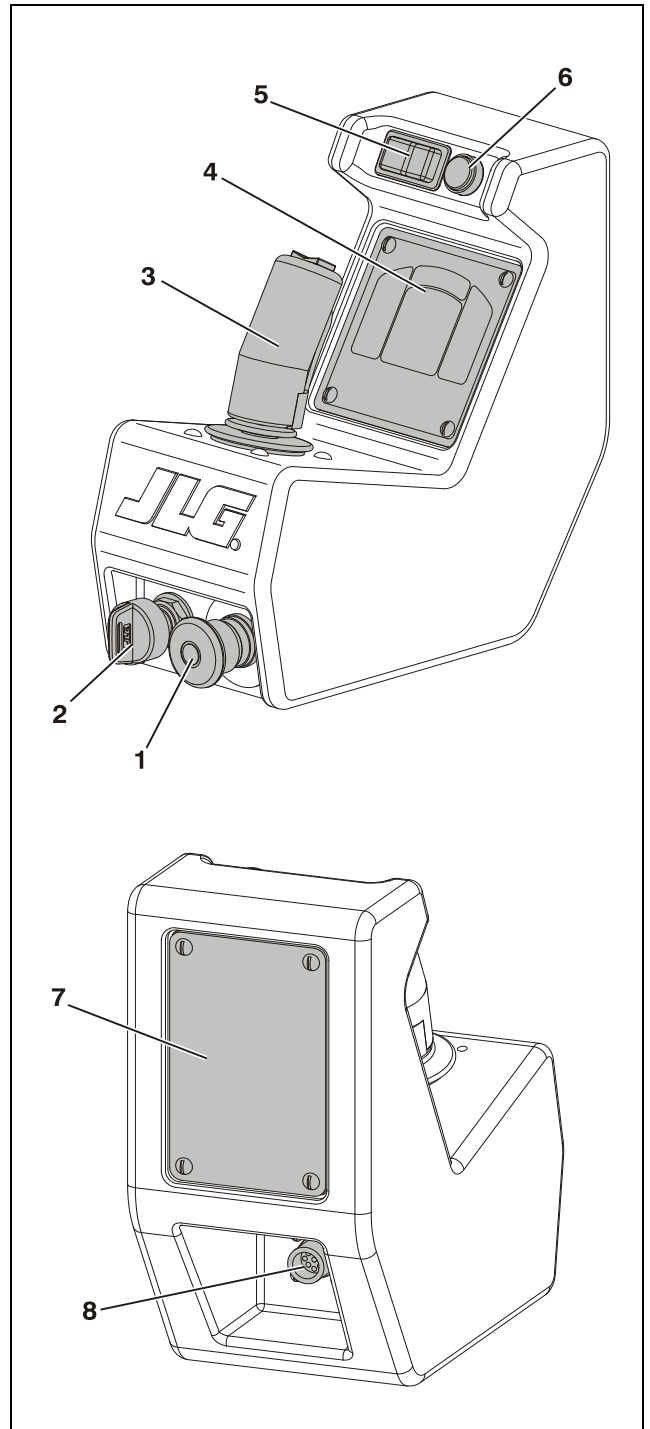

Figure 4-5. Platform Control Console Components.

- | | |
|------------------------------|------------------------------------|
| 1. E-Stop/Shutdown Switch | 5. Drive/Lift Mode Selector Switch |
| 2. ON/OFF Key Switch (a) | 6. Horn Button Switch |
| 3. Joystick Assembly | 7. Rear Cover |
| 4. Display/Controller Module | 8. Wiring Harness Connector |

NOTE: (a) No key switch on Australian spec. machines.

Display/Controller Module Electrical Connections

The internal switches and joystick controller of the platform console plug directly into the Display/Controller Module. This module then relays the signals from these switches to the Ground Control Box through the communications cable running to the platform junction box mounted to the mast under the platform.

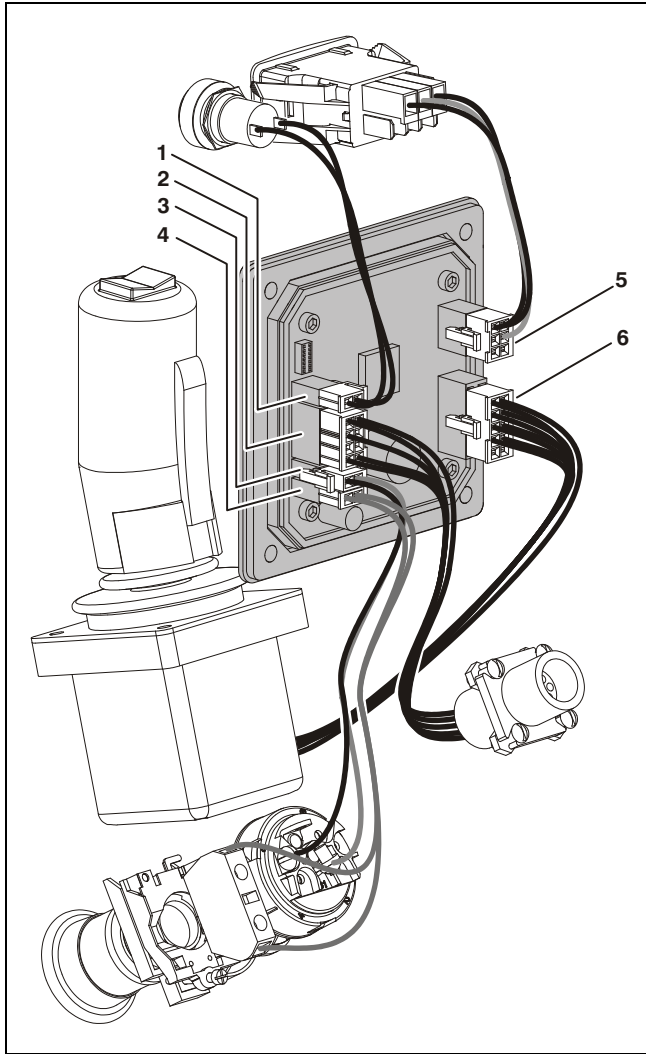

Platform Console - Circuit Board Connections

- | | |
|---|---|
| 1. Horn Switch - (C5) | 4. E-Stop/Shut-Down Switch - (C4) |
| 2. Communications Cable to Platform Junction Box - (C6) | 5. Drive/Lift Mode Select Switch - (C7) |
| 3. ON/OFF Key Switch (C3) | 6. Joystick - (C8) |

Note: The (C) numbers shown after the description above represent the corresponding identification of the plug on the module's circuit board.

Mounting Bracket - Install/Remove

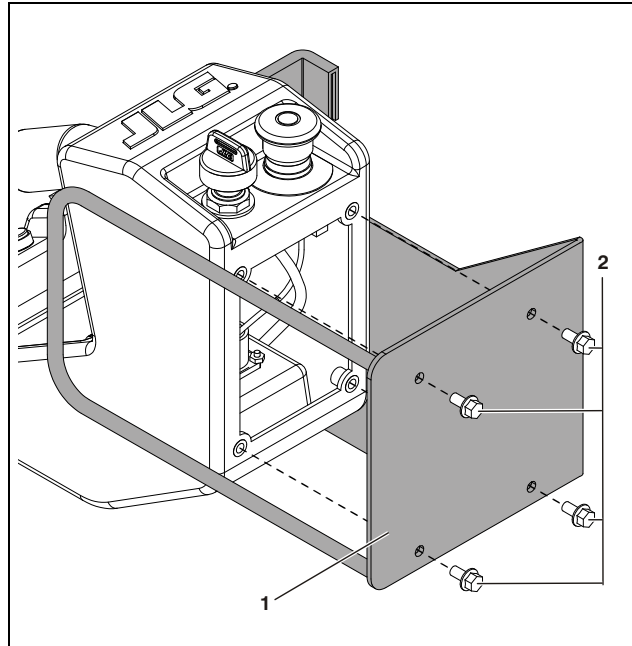

Platform Console - Mounting Bracket

- | | |
|---------------------|-----------------------|
| 1. Mounting Bracket | 2. Bracket Screws (a) |
|---------------------|-----------------------|

Note: (a) Apply Loctite #242 to screw threads on final assembly.

Rear Cover - Install/Remove

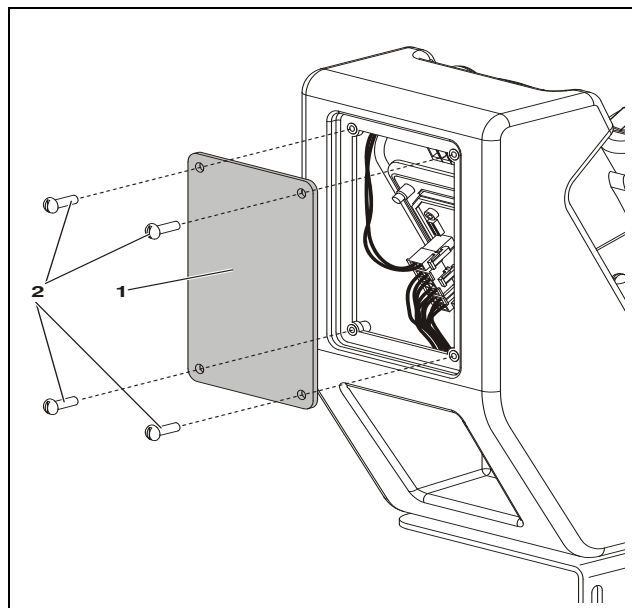

Platform Console - Rear Cover Installation

- | | |
|---------------|--------------------------|
| 1. Rear Cover | 2. Cover Mounting Screws |
|---------------|--------------------------|

Display/Controller Module - Install/Remove

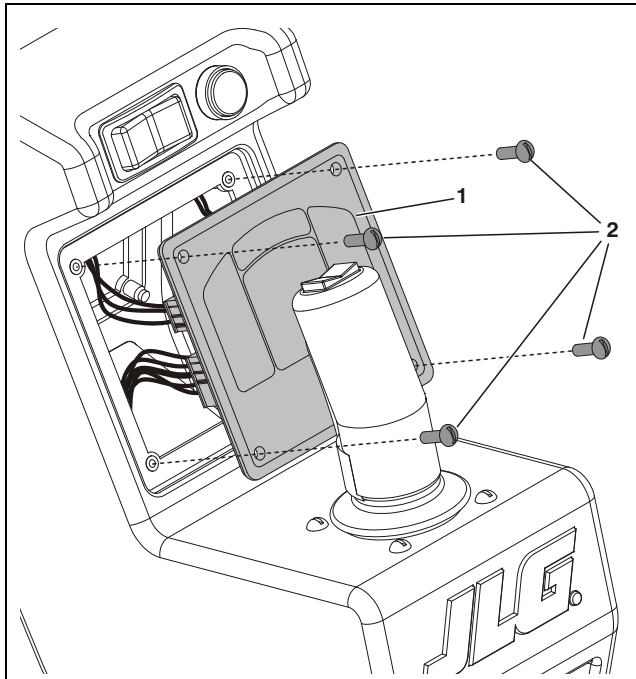

Platform Console - Display Module

1. Display/Controller Module (a) 2. Mounting Screws

Note: (a) Unplug all connections on the back of the module before removing from console.

Horn Button Switch - Install/Remove

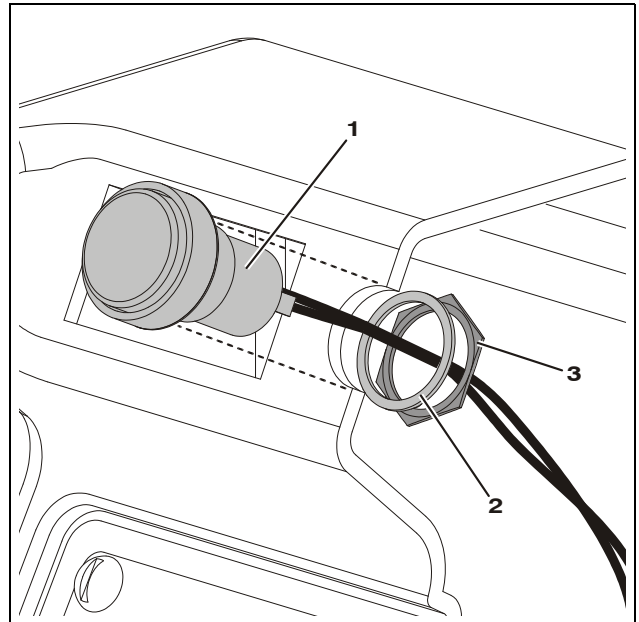

Platform Console - Horn Switch Installation

1. Horn Button Switch (a) 3. Nut
2. Lock Washer

Note: (a) Remove rear cover, unplug wire, remove nut and lock washer then slide switch out of console.

Drive/Lift Mode Switch - Install/Remove

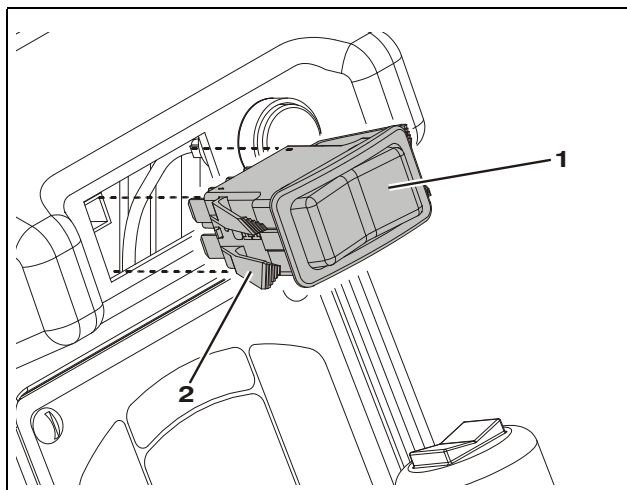

Platform Console - Drive/Lift Mode Select Switch

1. Switch Assembly (a) 2. Locking Tabs

Note: (a) Remove rear cover, unplug switch wire, press tabs to remove.

Key Switch - Install/Remove

(No key switch on Australian specification machines.)

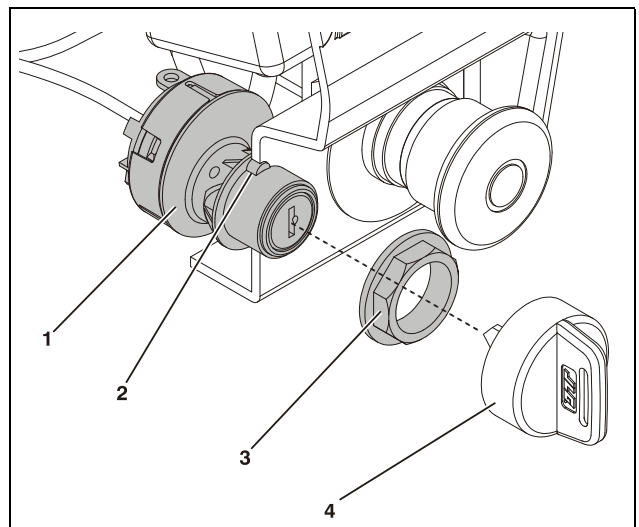

Platform Console - Key Switch Installation

1. Key Switch (a) 3. Attach Nut
2. Notch 4. Key

Note: (a) Remove mounting bracket on bottom of console to gain access to the key switch assembly.

SECTION 4 - CONTROL COMPONENTS

E-Stop/ShutDown Switch - Install/Remove

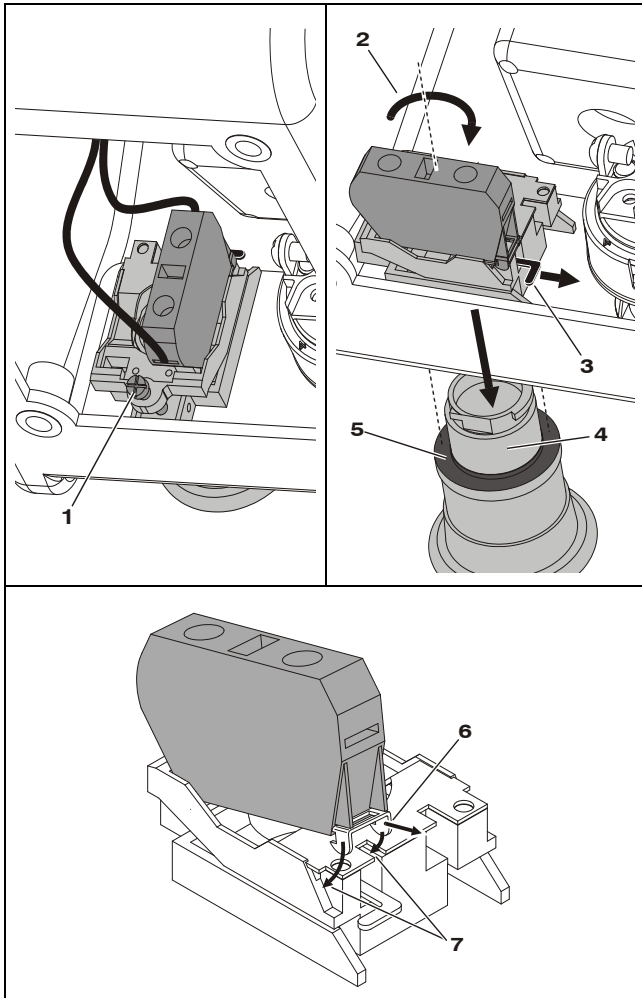

Platform Console - E-Stop Switch Installation

1. Loosen Switch Set Screw
2. Turn Switch 90°
3. Pull Spring-Loaded Release Lever Out
4. Remove Barrel Assembly
5. Barrel Seal
6. Switch to Body Retainer Hooks (a)
7. Switch Retainer Slots

Note: (a) Use a small straight blade screwdriver to extend the spring-loaded retainer hooks (6) out and release the switch from the body.

Joystick Assembly - Install/Remove

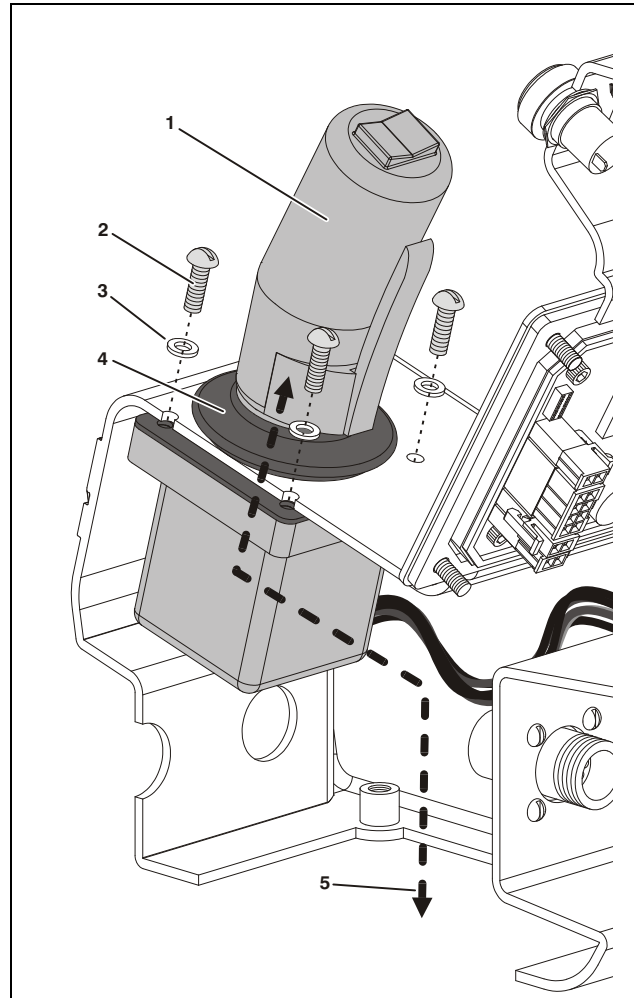

Platform Console - Joystick Installation

1. Joystick Assembly
2. Attach Screws (Qty.-4)
3. Nylon Washers (Qty.-4)
4. Rubber Boot/Gasket
5. Install/Remove through the Access Hole in Bottom of Housing. (a) (b)

Note: (a) Remove the console mounting bracket.
(b) Remove the key switch and e-stop switch to remove joystick assembly through access hole in bottom of console.

4.8 PUMP-MOTOR ASSEMBLY - SERVICE PROCEDURE

Hydraulic Pressure settings and Adjustment

Adjust system pressure so that platform will raise with maximum rated capacity in platform.

The following pressure setting are factory recommended (initial) settings;

MODEL	PRESSURE SETTING
15MVL/15MSP	2600 PSI
20MVL	1800 PSI
20MSP	2800 PSI

Turning adjustment screw **clockwise increases system pressure**, turning screw **counterclockwise decreases system pressure**. (See Figure 4-6., Hydraulic Pressure Adjustment Screw. (Machine Rear Covers Removed))

Perform pressure adjustment with oil at normal operating temperature. If pressure is set when oil is cold, platform may not raise rated load after soil has warmed.

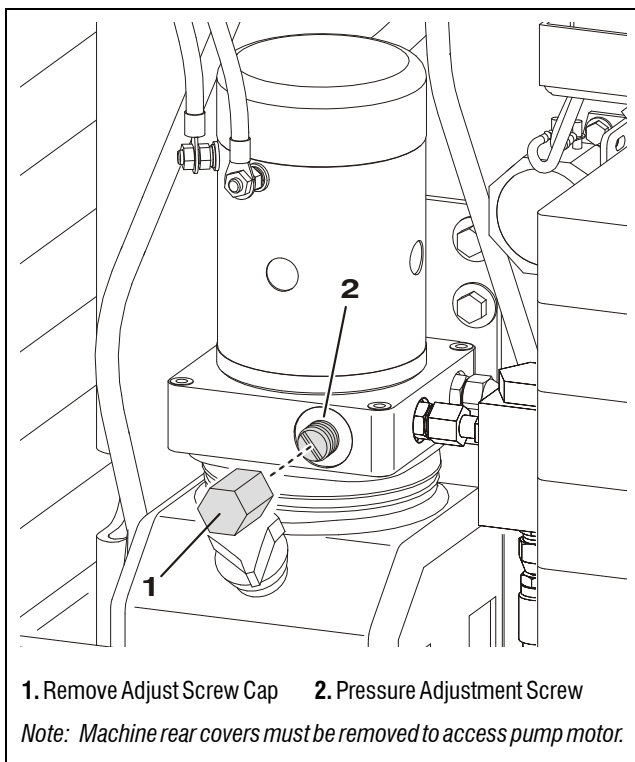

Figure 4-6. Hydraulic Pressure Adjustment Screw. (Machine Rear Covers Removed)

Hydraulic Pressure Gauge Connection

⚠ CAUTION

ONLY OPEN HYDRAULIC SYSTEM LINES WITH THE MAST FULLY LOWERED TO RELIEVE PRESSURE IN THE SYSTEM. CAREFULLY LOOSEN REQUIRED FITTINGS, WEAR SAFETY PROTECTION EQUIPMENT WHEN WORKING WITH HYDRAULIC SYSTEMS.

Remove the hydraulic oil filter and install a t-fitting between the pump and the extend line to connect a hydraulic pressure gauge as shown in Figure 4-7., Typical Hydraulic Pressure Gauge Installation (Hydraulic Filter Removed).

CHECK, and if necessary, ADJUST the hydraulic pressure to initial settings shown in table at the beginning of this section. Cycle the hydraulic system several times with the maximum load capacity in the platform, then recheck pressure setting. When pressure has stabilized continue to "After Filter Pressure Check" following.

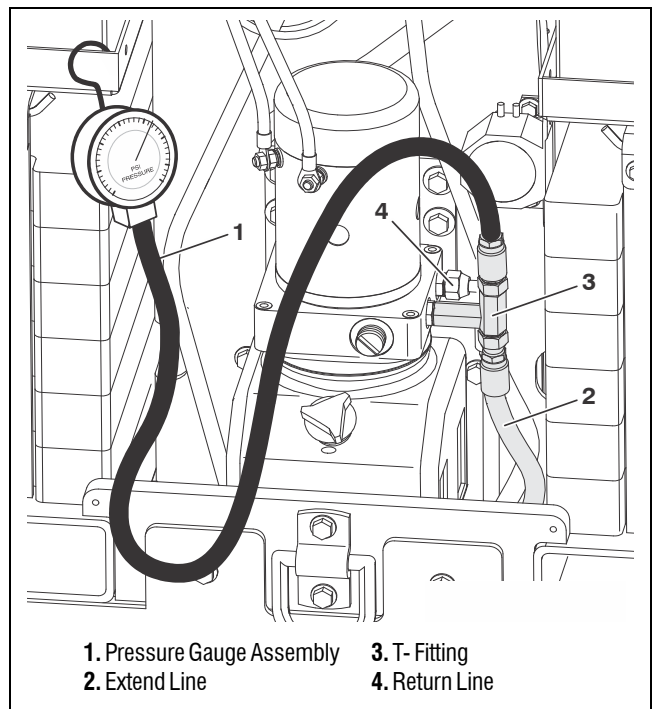

Figure 4-7. Typical Hydraulic Pressure Gauge Installation (Hydraulic Filter Removed).

After Filter Pressure Check

Reinstall the hydraulic oil filter and install the t-fitting between the hydraulic filter and the extend line to the cylinder. Recheck the hydraulic pressure and compare with the previous readings when filter was removed. If a significant drop in pressure reading has occurred, replace the hydraulic filter and recheck the "after filter" pressure reading.

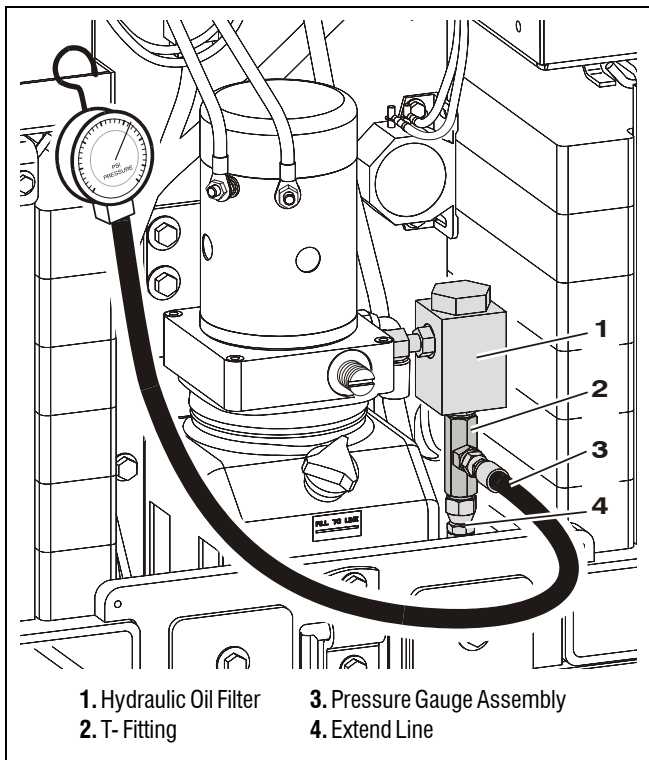
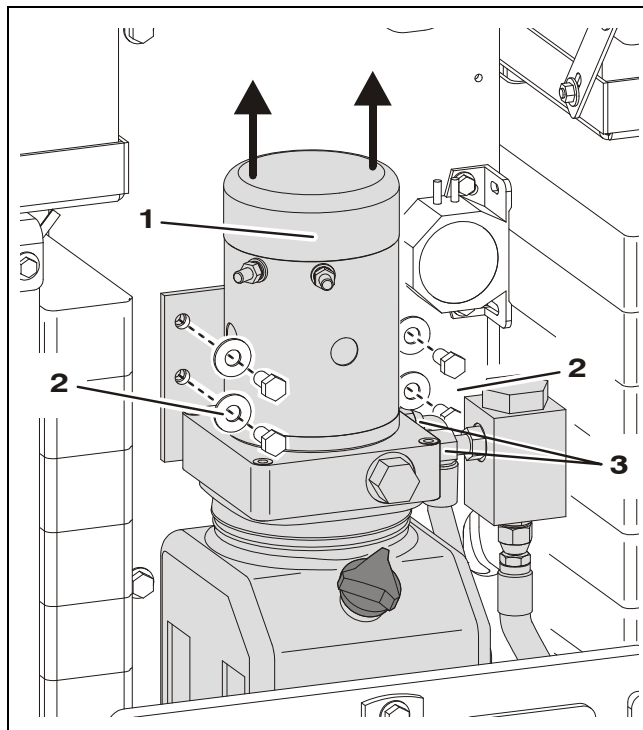

Figure 4-8. Typical Hydraulic Pressure Gauge Installation (After Hydraulic Filter).

Pump/Motor/Tank Installation

NOTICE

BE CERTAIN THE MAST IS FULLY LOWERED BEFORE REMOVING ANY HYDRAULIC LINES FROM THE PUMP UNIT. WEAR PROTECTIVE GEAR WHEN WORKING AROUND PRESSURIZED HYDRAULIC LINES. REMOVE CONNECTIONS CAREFULLY AND CAP ALL LINES.



Pump/Motor/Tank Assembly Installation

- 1. Pump/Motor/Tank Assembly
- 2. Attach Screws/Washers
- 3. Detach and Cap Extend and Return Lines

Note: See Figure 4-2. for wiring connection instructions.

General Installation and Disassembly

The following is a complete disassembly/assembly of the MVL/MSP machines pump/motor assembly. No internal parts to the hydraulic pump are serviced by JLG except for a pump installation seal kit. Also the only parts serviceable internal to the pump electric motor is the motor brush kit.

NOTE: During reassembly of the pump/motor assembly, apply a liberal coat of JLG recommended hydraulic fluid to all seals and o-rings. Also keep all internal metal parts clean and coated with hydraulic fluid to prevent surface corrosion. JLG recommends replacing all seals and o-rings when disassembling and reassembling the pump/motor unit.

The motor and motor brushes can be serviced without removing the complete pump/motor unit. However components on the bottom end of the unit will require removal of the complete pump/motor unit. See Pump/Motor/Tank Installation instructions following.

Inline Hydraulic Filter Installation

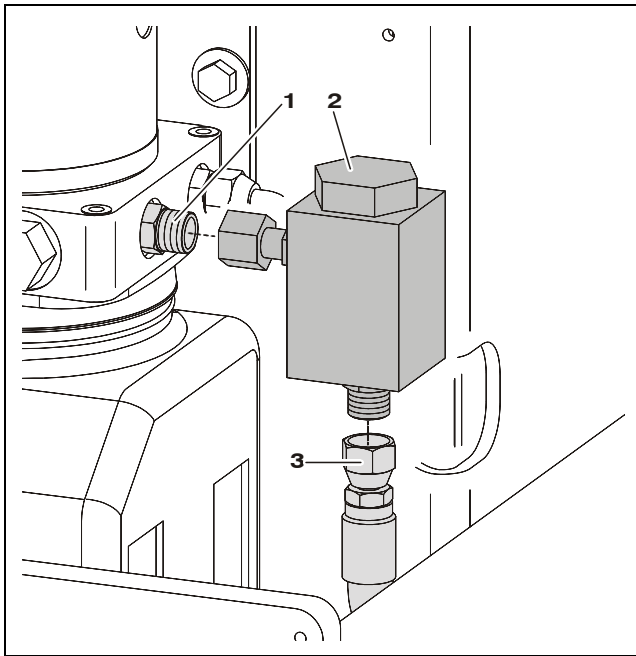

Pump/Motor/Tank Assembly Installation

- 1. Valve Body Extend Line Fitting
- 2. Inline Hydraulic Filter
- 3. Extend Line to Lift Cylinder

FENNER BRAND PUMP - Brush Replacement

Motor Cap/Motor Installation

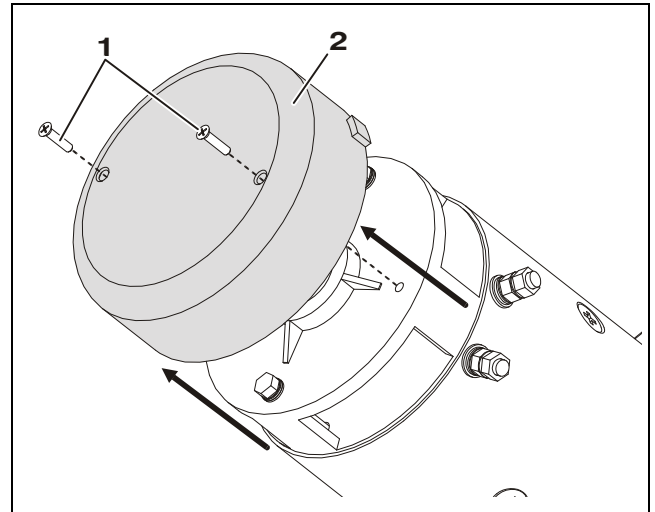

Motor Cap Installation

- 1. Cap Assembly Screws
- 2. Cap Assembly

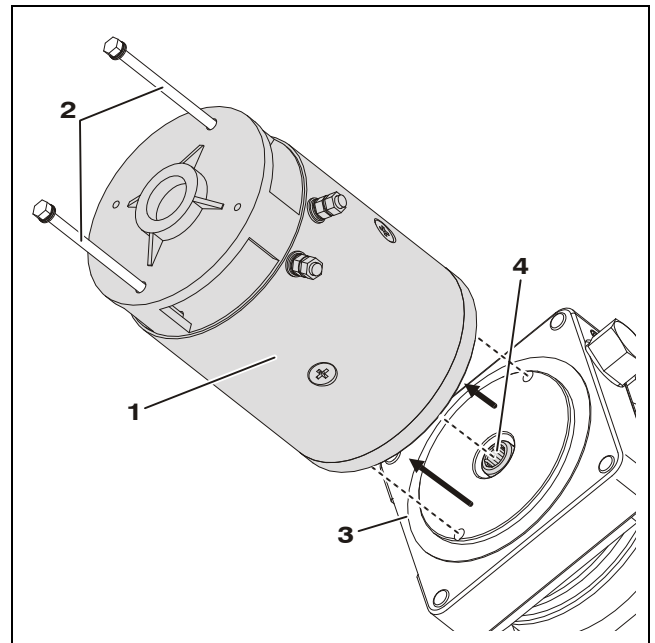

Motor Installation

- 1. Motor Assembly
- 2. Motor Assembly Screws
- 3. Pump End Head
- 4. Motor to Pump Coupler

SECTION 4 - CONTROL COMPONENTS

Motor Brush Installation

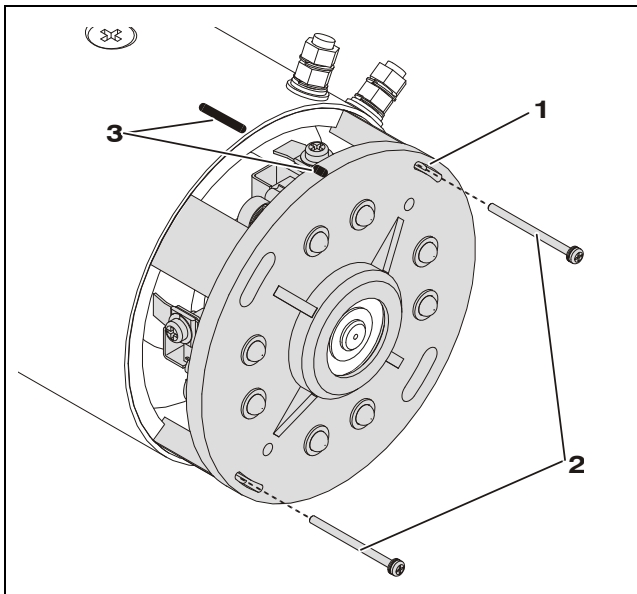

Brush Housing Installation

1. Brush Housing
2. Brush Housing Screws
3. Mark Front of Motor and Brush Housing for reference when reassembling.

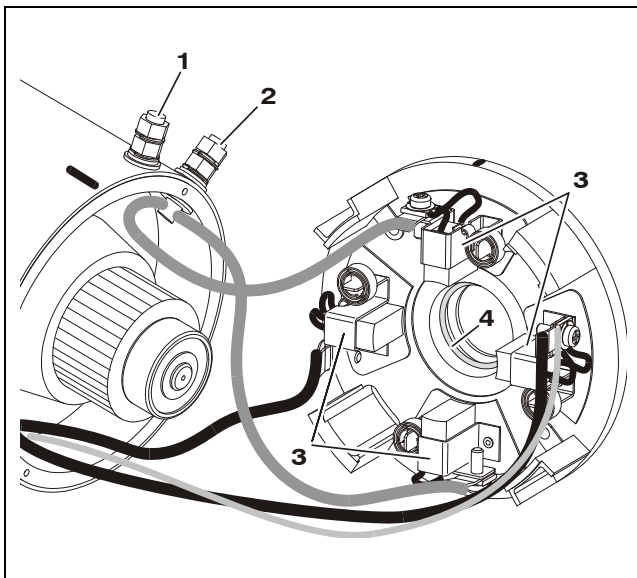

Brush Assembly Connections

1. Negative (-) Post
2. Positive (+) Post
3. Brush Assemblies
4. Spring Washer

Note: Length of wires to brush assemblies shown exaggerated for illustrative purposes.

Once brush housing has been removed, inspect the rotor commutator for excessive wear before installing a new brush set.

The rotor commutator surface when new, is approximately 1/8 in. (3mm) in thickness.

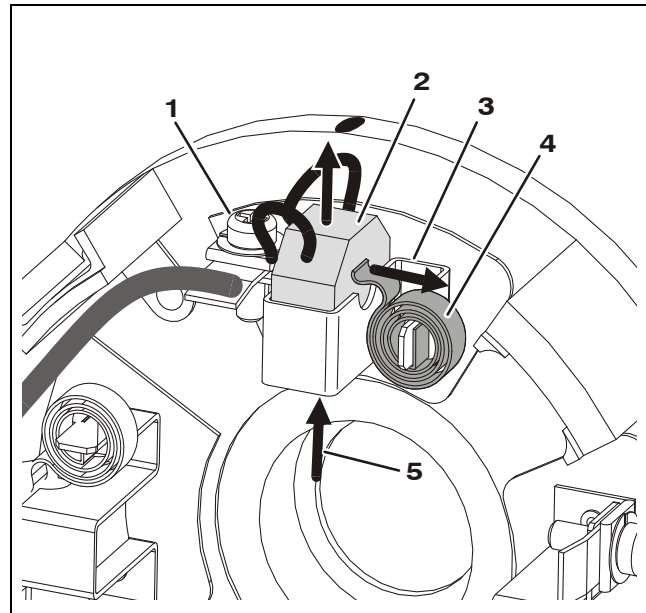

New Brush Installation

1. Brush Terminal Screw
2. Brush
3. Brush Holder
4. Brush Spring
5. (See Installation Note Below)

Installation the same for all four (4) brush assemblies.

Note: Using a clean towel, push each brush (2) up into it's holder (3), slide the spring (4) over the side of the brush. This will hold each brush in place and allow them to clear the rotor commutator during reassembly.

Clean the rotor commutator with a non-conductive electrical cleaner before assembling the brush housing to the motor housing.

Brush Housing Final Assembly Tips

It is easier to install the brush housing assembly by sliding the rotor assembly completely out of the other end of the motor housing, then attach the brush housing first. After the brush housing is installed look into the motor housing from the opposite end to check that the positive (+) post wires and static winding wires are positioned, not to block the holes for the motor mounting bolts, inside the motor housing.

After final assembly of the brush housing check that all brush terminal screws are tight and the brush springs are positioned properly before mounting the motor to the pump/motor end head.

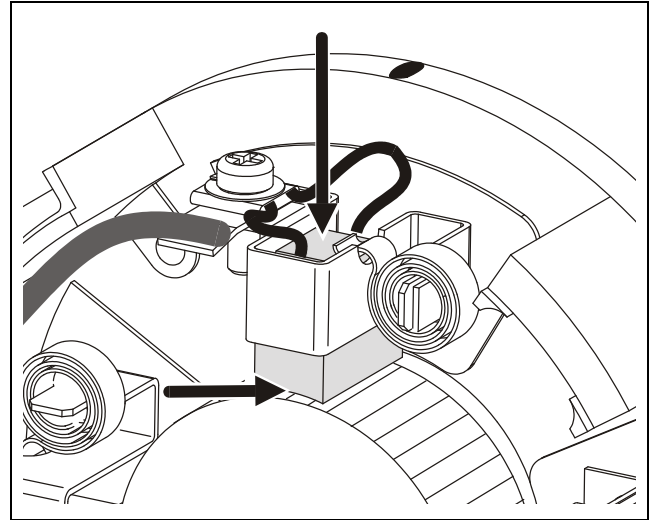

Brush Final Positioning

NOTICE

ONCE THE ROTOR ASSEMBLY IS IN PLACE, REMEMBER TO PUSH EACH BRUSH DOWN UNTIL THE BRUSH FACE IS IN CONTACT WITH THE COMMUTATOR ON THE ROTOR SHAFT AND THE BRUSH SPRING IS PUSHING DOWN ON TOP OF THE BRUSH.

MONARCH BRAND PUMP - Brush Replacement

Motor Assembly - Remove/Install - Reference Marks

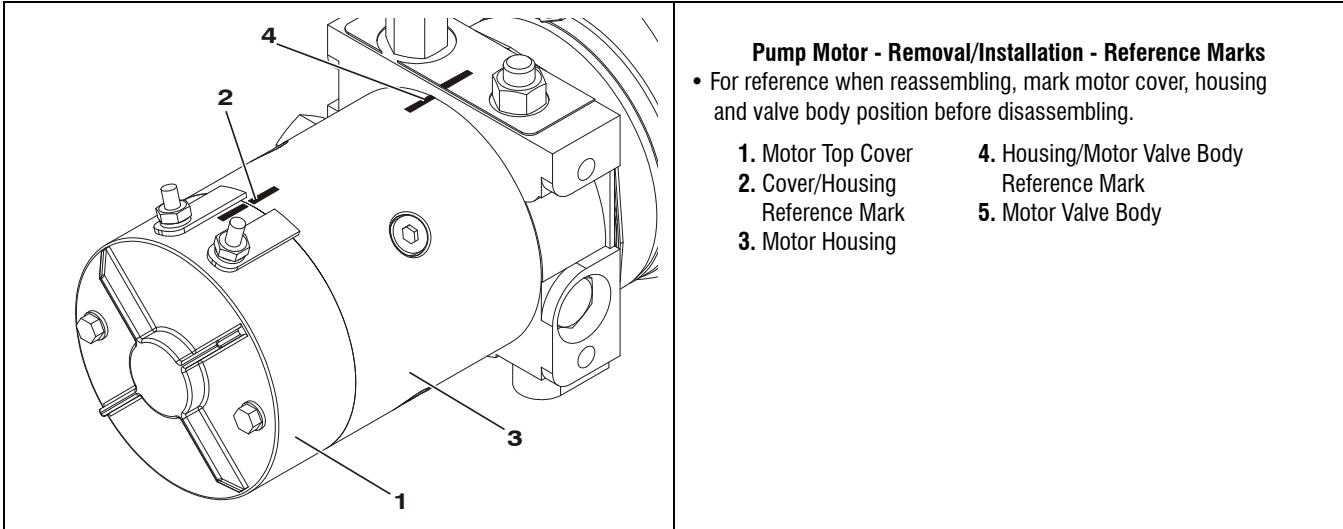

Pump Motor - Removal/Installation - Reference Marks
 • For reference when reassembling, mark motor cover, housing and valve body position before disassembling.

- | | |
|---------------------------------|--|
| 1. Motor Top Cover | 4. Housing/Motor Valve Body Reference Mark |
| 2. Cover/Housing Reference Mark | 5. Motor Valve Body |
| 3. Motor Housing | |

Motor/Brush Cover - Remove/Install

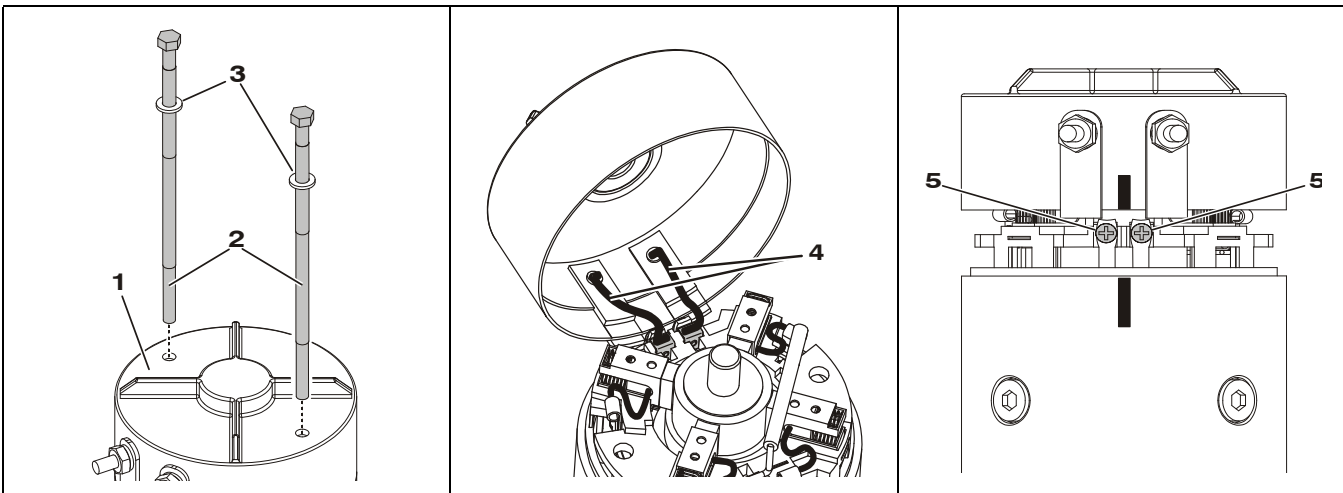

Motor/Brush Cover - Removal/Installation

- | | | |
|--------------------------|---|----------------------------------|
| 1. Motor/Brush Cover (a) | 3. Washers | 5. Power Lead Clip Attach Screws |
| 2. Cover Screws (b) | 4. Power Leads to Lead Clips (Soldered) | |

NOTICE

REMOVE THE MOTOR COVER CAREFULLY, THE (SHORT) POWER LEADS INSIDE THE COVER FROM THE (+/-) POSTS ARE SOLDERED TO ATTACH CLIPS WHICH ARE FASTENED TO THE BRUSH CARRIER ASSEMBLY WITH SCREWS (ITEM-5). RAISE THE COVER STRAIGHT UP - REMOVE THE SCREWS - THEN HINGE THE COVER UP (SEE CENTER ILLUSTRATION) AND PRY THE CLIPS OFF OF THE BRUSH CARRIER ASSEMBLY TO COMPLETELY REMOVE THE MOTOR COVER.

NOTE: (a) Once cover screws are removed, you may need to tap lightly around the edge of the top cover to separate it from the motor housing. Read the important note above before attempting to remove the cover.
 (b) These steel screws are threaded into the aluminum valve body, do not overtighten.

Brush Carrier Assembly - Remove/Install

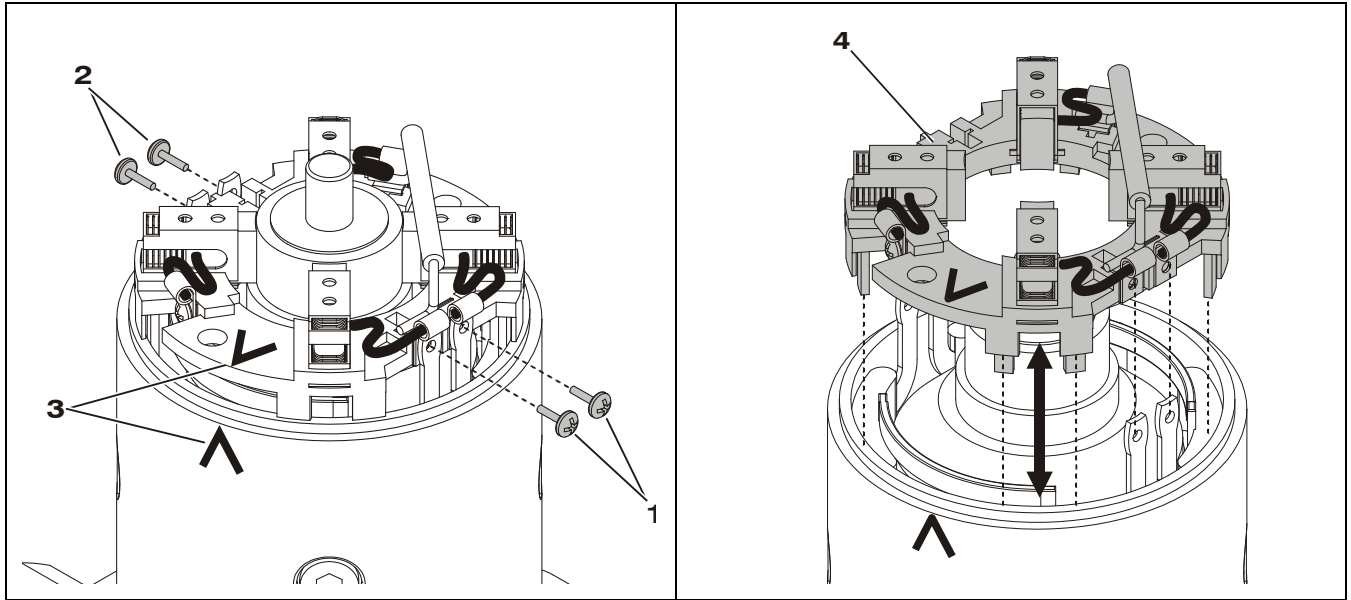

Brush Carrier Assembly - Remove/Install

- | | |
|---|---|
| 1. Stator/Brush Carrier Screws (Pump Rear) | 3. Mark Brush Carrier Position on Motor Housing |
| 2. Stator/Brush Carrier Screws (Pump Front) (a) | 4. Brush Carrier Assembly |

NOTE: (a) Removed previously with motor cover disassembly (shown for reference only).

Brush Assembly - Remove/Install

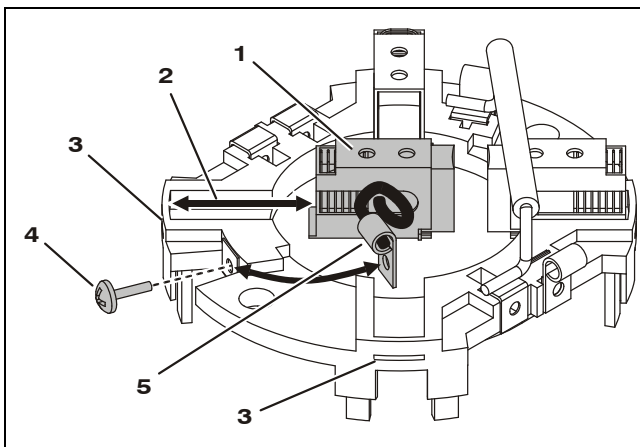

Brush Assembly - Remove/Install

- | | |
|-------------------------|--------------------------|
| 1. Brush Assembly (a) | 4. Brush Terminal Screw |
| 2. Brush Carrier Socket | 5. Brush Attach Terminal |
| 3. Brush Tab Slot | |

NOTE: (a) Slide brush assembly into socket until tab is in slot at rear of socket.

Tank Installation

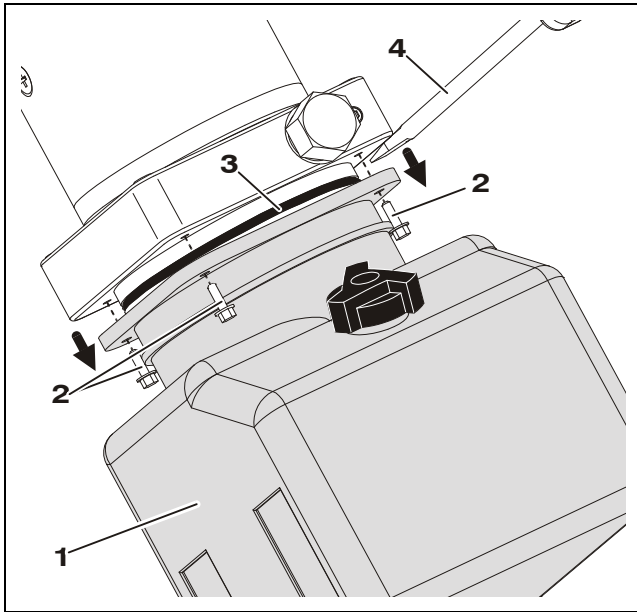

Tank Installation

- 1. Tank Assembly
- 2. Tank Screws (4)
- 3. O-Ring Seal
- 4. Use Screwdriver to pry tank away from pump head.

Pump Installation

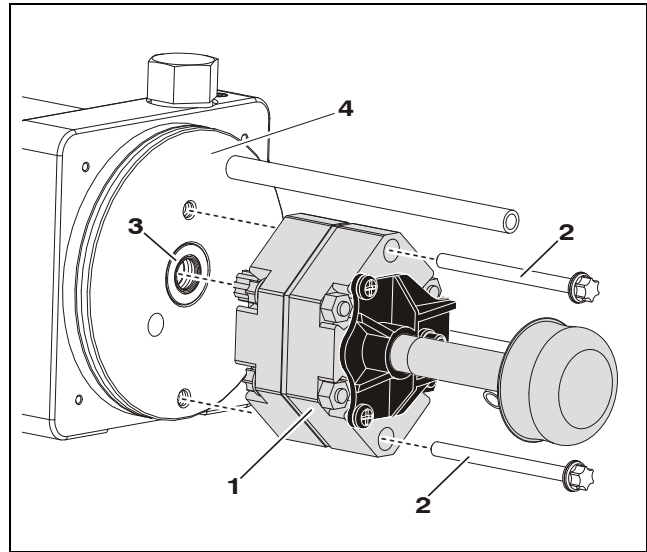

Pump Installation

- 1. Pump Assembly
- 2. Pump Assembly Screws
- 3. Pump Shaft Seal
- 4. Pump End Head

Filter Screen Installation

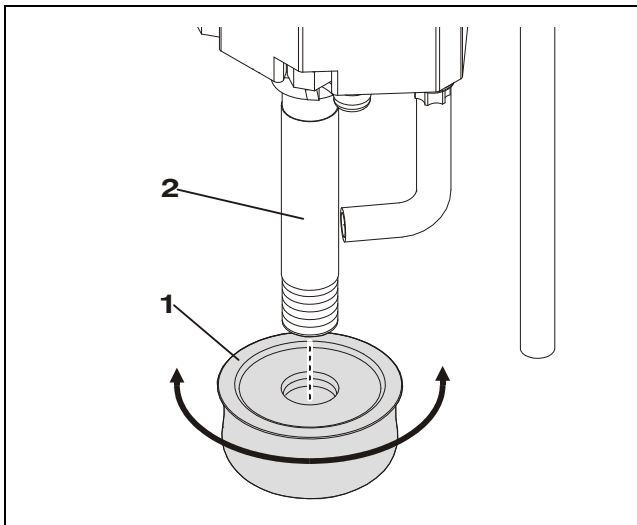

Filter Screen Installation

- 1. Filter Screen
- 2. Pump Pick-Up Tube

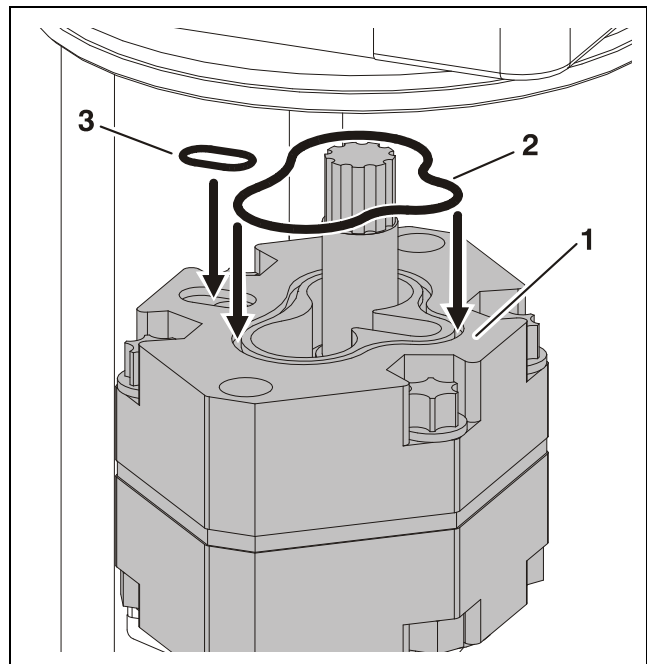

Pump O-Ring Installation

- 1. Pump Assembly
- 2. O-Ring Seal
- 3. O-Ring Seal

Pressure Adjust Valve Installation

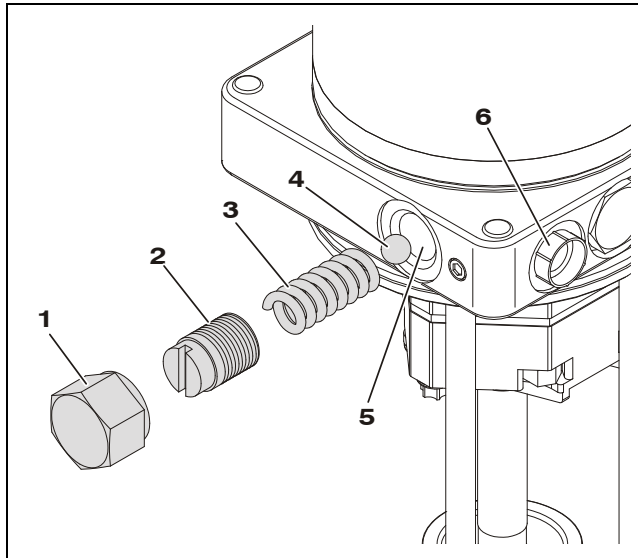

Pressure Adjust Valve Installation

- | | |
|---------------------|--|
| 1. Adjust Valve Cap | 4. Valve Ball |
| 2. Adjustment Screw | 5. Adjust Valve Port |
| 3. Valve Spring | 6. Extend (Pressure) Port
(Shown Plugged) |

Note: Adjust pressure per specification shown in Section-1 of this Service Manual.

Pressure Check Valve Installation

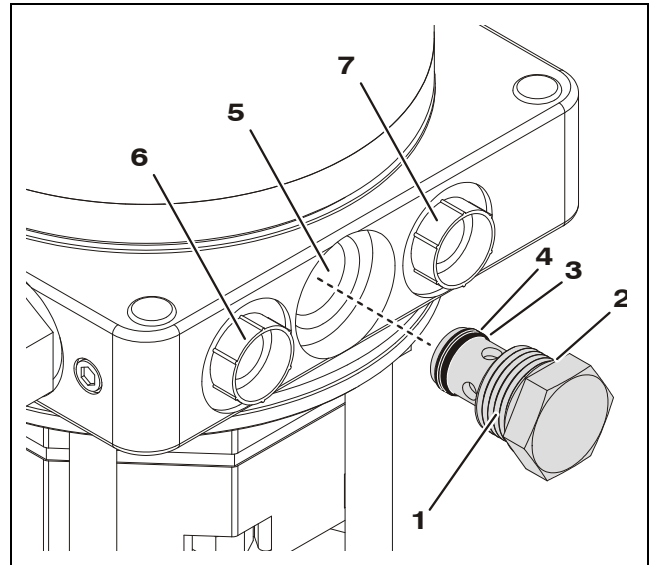

Pressure Check Valve Installation

- | | |
|-------------------------|---------------------------|
| 1. Check Valve Assembly | 5. Check Valve Port |
| 2. O-Ring Seal | 6. Extend (Pressure) Port |
| 3. O-Ring Seal | 7. Return Port |
| 4. Backing Ring | |

Note: Extend (Pressure) and Return Ports Shown Plugged

4.9 OBSTRUCTION SENSOR SYSTEM - SERVICE PROCEDURE (MSP - OPTION)

General

The Obstruction Sensor System (OSS) Control Module is mounted between the rails of the mast platform header section under the platform decal billboard at the rear of the MSP model platform, see illustration below.

The OSS Control Module communicates with the Ground Control Module through the platform electrical junction box also mounted on the mast behind the platform decal billboard.

The OSS Control Module circuit board monitors six (6) channels each channel is wired to an individual transducer sensor mounted under the MSP model platform. The sensors are mounted in a manner to provide a detec-

tion zone beneath the platform and detect if an object has entered that zone when the platform is being lowered.

NOTE: The OSS only operates normally when the Ground Control Module - Power Selector Switch (Key) is set to PLATFORM CONTROL MODE.

When the Power Selector Switch (Key) is set to GROUND CONTROL MODE the OSS will detect an obstruction but will not stop platform downward movement or sound the horn. However, the OSS Control Module LED will flash if a sensor detects the presence of an object.

An OSS Sensor replacement kit is available from the JLG Parts Department for individual sensors. The kit provides instructions and everything necessary to connect the new sensor to the existing soldered wire ends.

If the OSS Control Module has failed it is recommended to replace the complete OSS system. See Section 6 of this manual for further OSS Troubleshooting instructions.

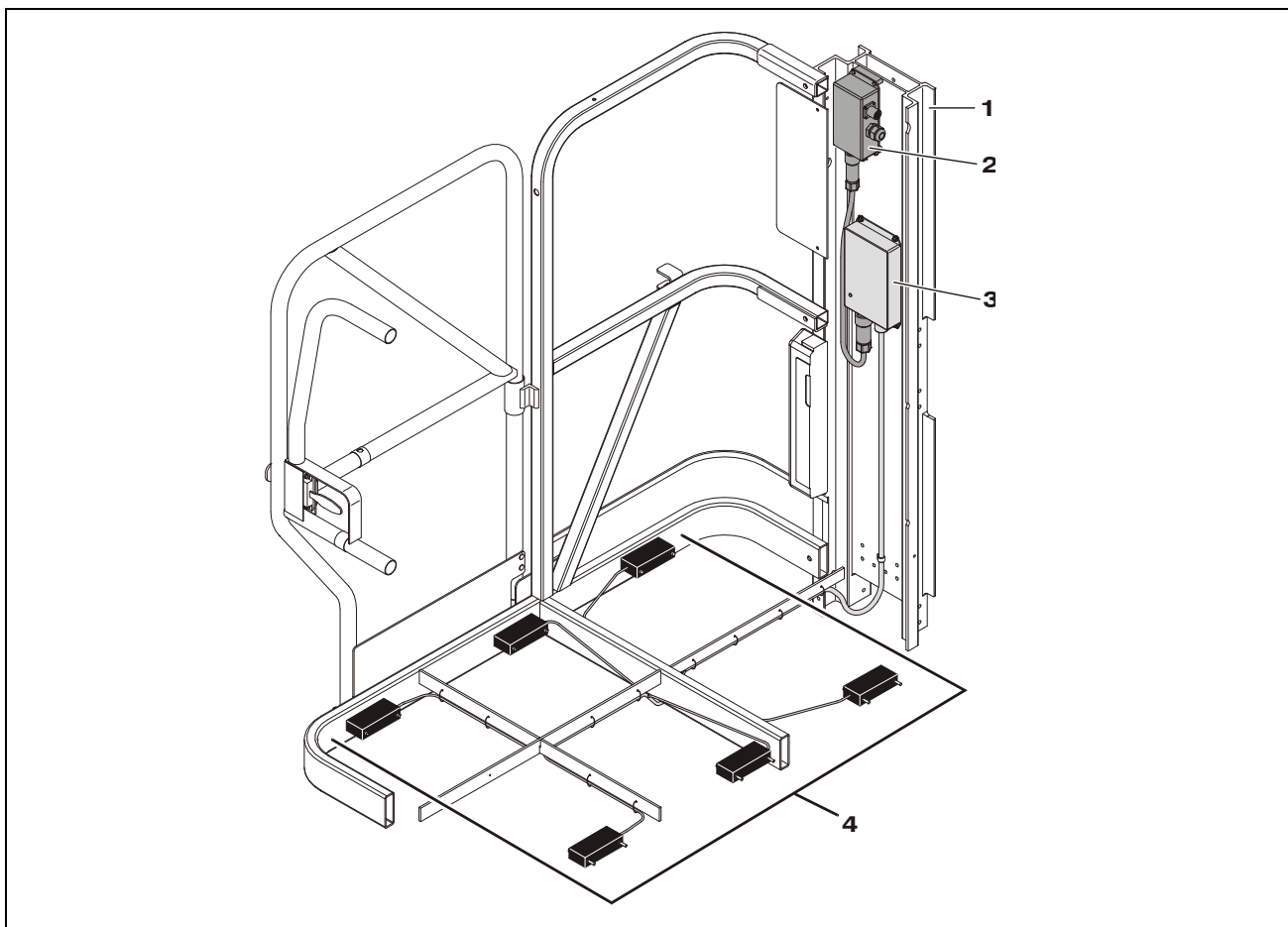

- | | |
|-------------------------------------|--------------------------------------|
| 1. Mast Platform Header Section | 3. Obstruction Sensor Control Module |
| 2. Platform Electrical Junction Box | 4. Transducer Sensor Arrangement |

Figure 4-9. Obstruction Sensor System Components (Platform Cutaway)

Transducer Sensor Check

Perform the following daily Pre-Start Inspection to check if each transducer sensor is working properly.

1. Power up machine by setting the Power Selector (Key) Switch to Ground Control Mode.
2. Raise the platform approximately four (4) to five (5) feet.
3. Hold an object about the size of 8-1/2 x 11 inches directly under one of the sensors. The OSS Control Module (RED) LED will flash if the sensor is working properly.
4. Remove object, allow the LED to stop flashing and check the next sensor, repeat this for all six (6) sensors.

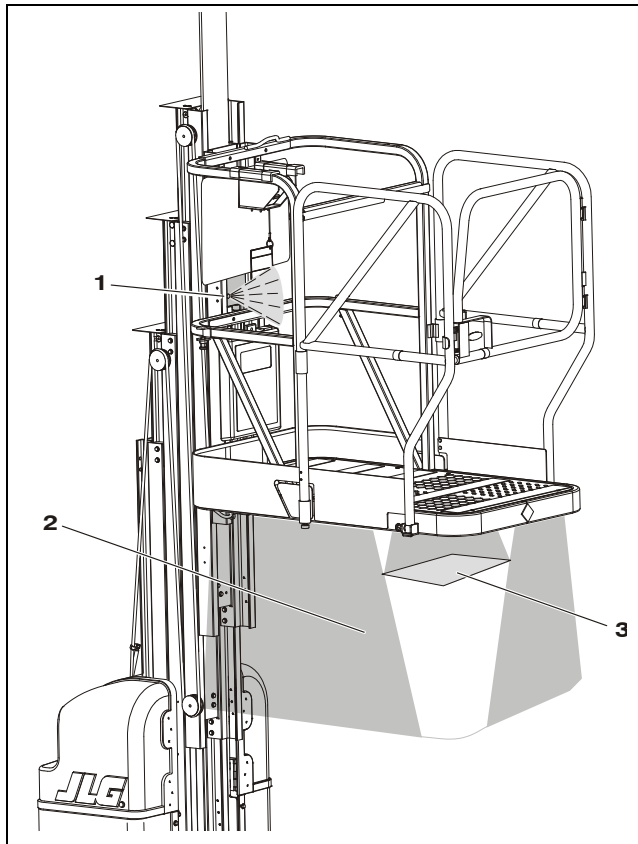

Transducer Sensor Check

1. Electronic Module LED Indicator (a)
2. Detection Zone
3. Place a pad of paper or similar size object, 6 to 12 in. (15 to 30cm) individually beneath each transducer to check detection.

Note: (a)The LED Indicator will flash when an object is detected at each sensor. Remove object and allow the LED to stop flashing before testing next sensor.

The Ground Control Module can also display the following sensor detection information when in Level 2 password Service and Maintenance Settings mode.

OSS Sensor

Displays current Obstruction Sensor System status (Detection - YES/NO). Also if an object is detected, the sensor(s) detecting the object and distance the object is from the sensor is displayed.

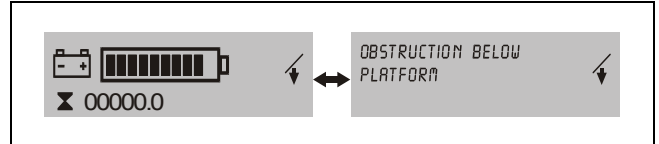

OSS Sensor LCD Display Mode

- | | |
|---------------------------------|--------------------------------|
| 1. Detection Indicator - Yes/No | 3. Object distance from sensor |
| 2. Sensor numbers | 4. Signal strength |

Note: This screen can be viewed while another person performs the transducer sensor check, see Section 4.9.

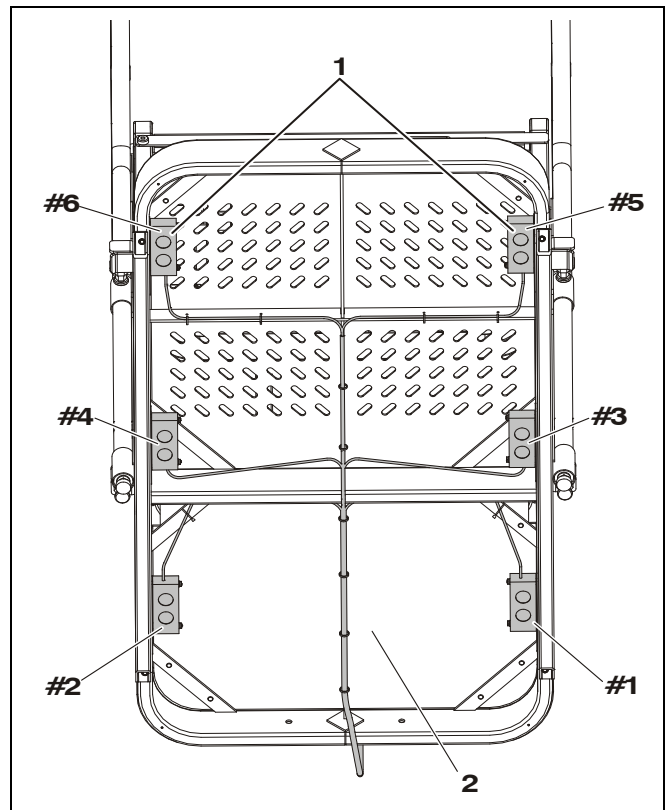

Transducer Sensor Locations

1. Transducer Sensors #1 through #6
2. Underside of MSP Platform

OSS Component Installation

NOTICE

THE FOLLOWING ILLUSTRATIONS PROVIDE KEY INSTALLATION INSTRUCTIONS FOR THE OSS TO OPERATE PROPERLY.

- The OSS Control Module must be electrically isolated from the mast, see installation instructions below.
- The sensor shield tubes attached to the platform's under sides must be properly installed and undamaged to prevent sensor detection of objects outside the platform parameter.
- The area under the platform floor must be free of any objects or debris dangling from beneath the platform to avoid false detection by the sensors.
- DO NOT allow high pressure spray to directly contact the transducer sensor (*circular*) membrane, this will damage the sensor.

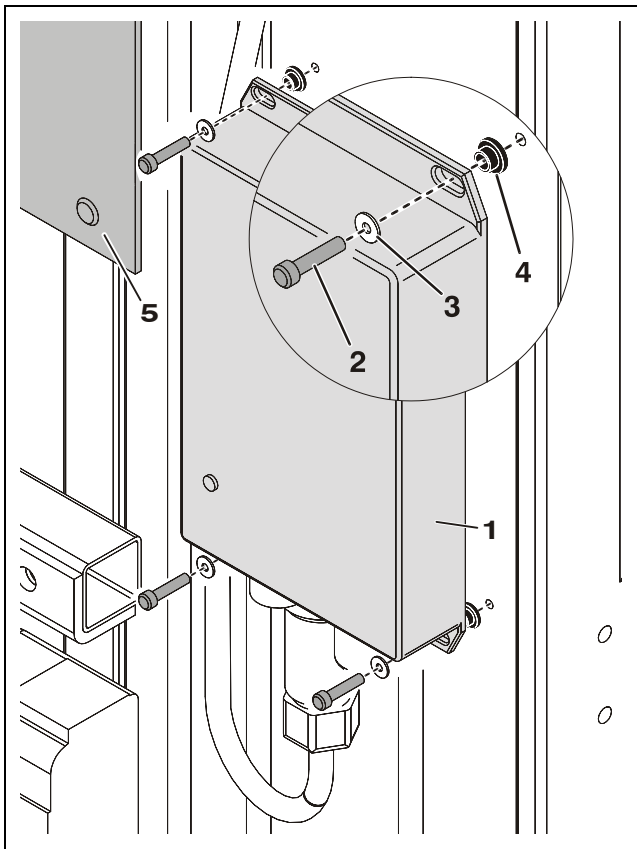

OSS Control Module Installation

- | | |
|-----------------------|------------------------|
| 1. OSS Control Module | 4. Insulating Bushing |
| 2. Mounting Screw (a) | 5. Decal Billboard (b) |
| 3. Nylon Washer | |

Notes: (a) Apply Loctite 222 to threads.
(b) Drill out pop rivets to remove.

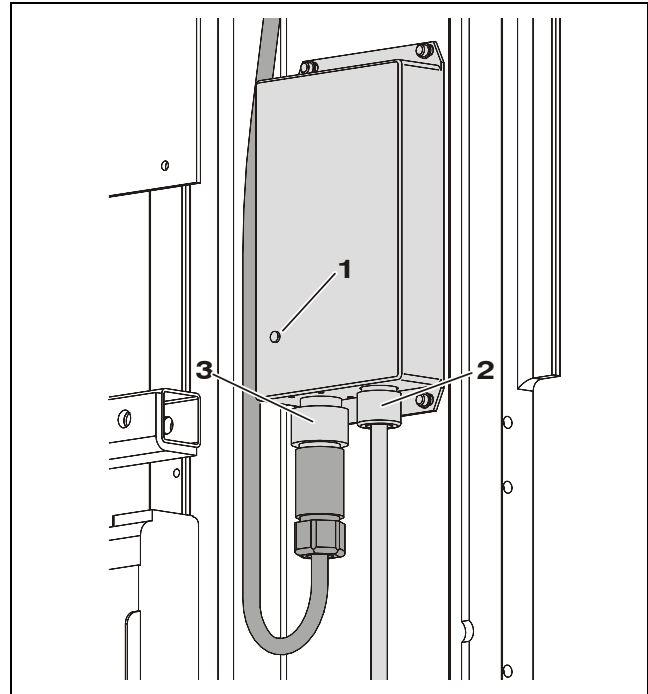

OSS Control Module Connections

- | | |
|--------------------------------|-------------------------|
| 1. RED LED Detection Indicator | 3. Junction Box Harness |
| 2. Sensor Harness | |

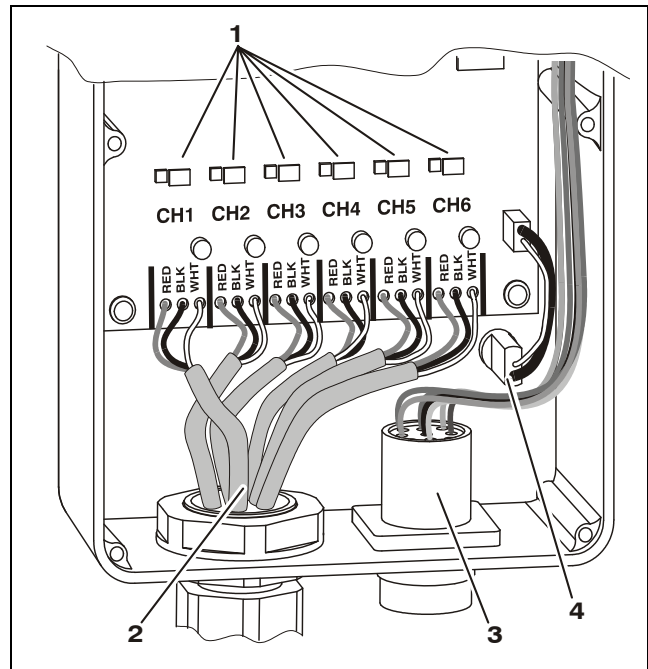

Internal View of OSS Control Module (Back Removed)

- | | |
|-----------------------------|---------------------------------|
| 1. Sensor Comm Channels (a) | 3. Wire Harness to Junction Box |
| 2. Sensor Cables | 4. LED Indicator Light |

Notes: (a) Channel 1-Sensor 1, Channel 2-Sensor 2, etc.

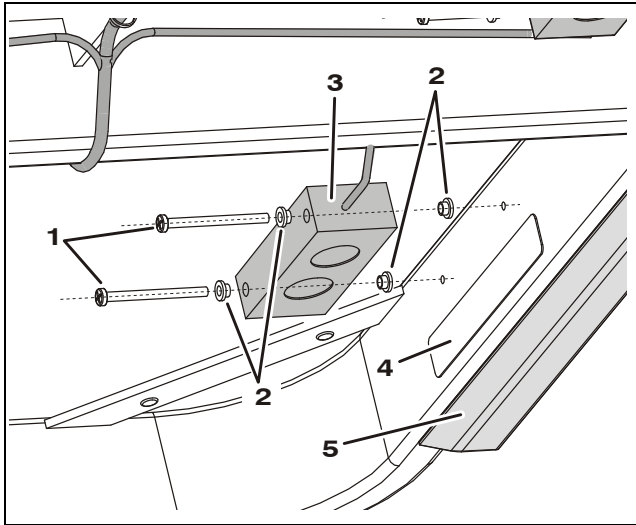

Transducer Sensor Installation (Typical)

- 1. Mounting Screws (a)
- 2. Bushings
- 3. Transducer Sensor (b)
- 4. DO NOT Pressure Wash Decal
- 5. Sensor Side Deflector

Notes: (a) Apply Loctite 222 to screw threads and torque to 15 in. lb.
 (b) Mount sensor with (circular) membrane facing down.

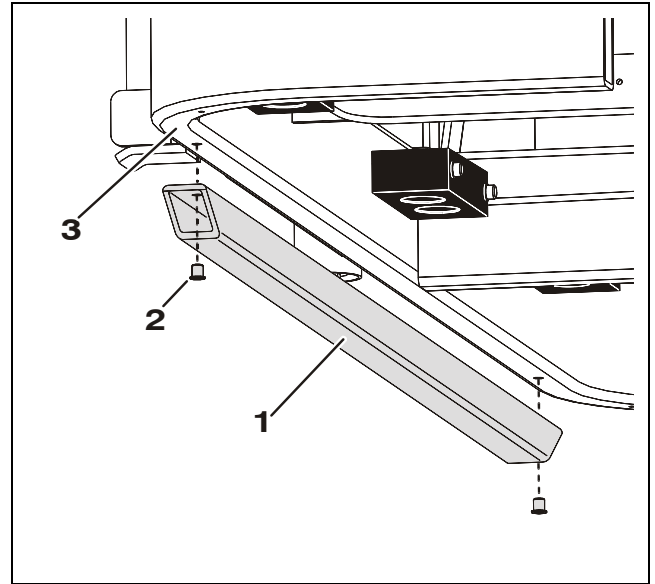

Sensor Side Deflectors

- 1. Sensor Side Deflector (a)
- 2. Pop Rivet
- 3. Platform Side Frame

Note: (a) One deflector required on each side of platform. Deflector must be even with, and not extend inside of the platform side frame.

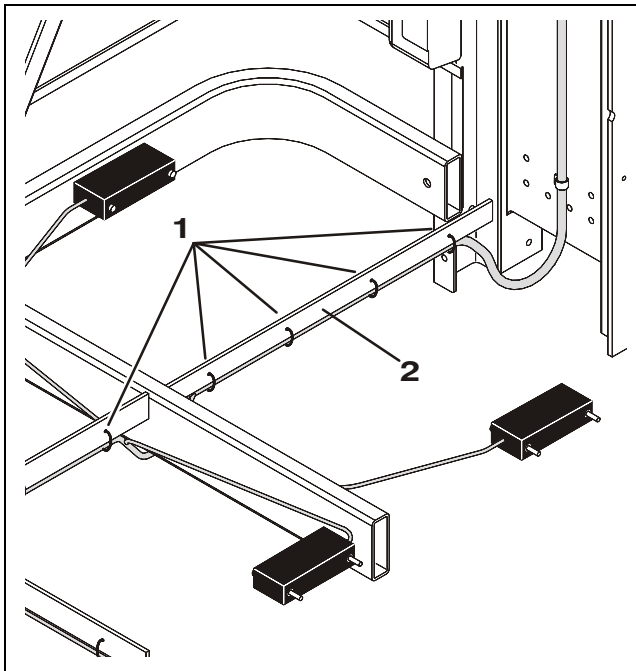

Secure Transducer Sensor Wiring

- 1. Nylon Tie Wraps (a)
- 2. Platform Floor Supports

Note: (a) Secure ALL sensor wire cables to platform side frame.

This page intentionally left blank.

SECTION 5. MAST COMPONENTS

5.1 MAST COMPONENTS OVERVIEW

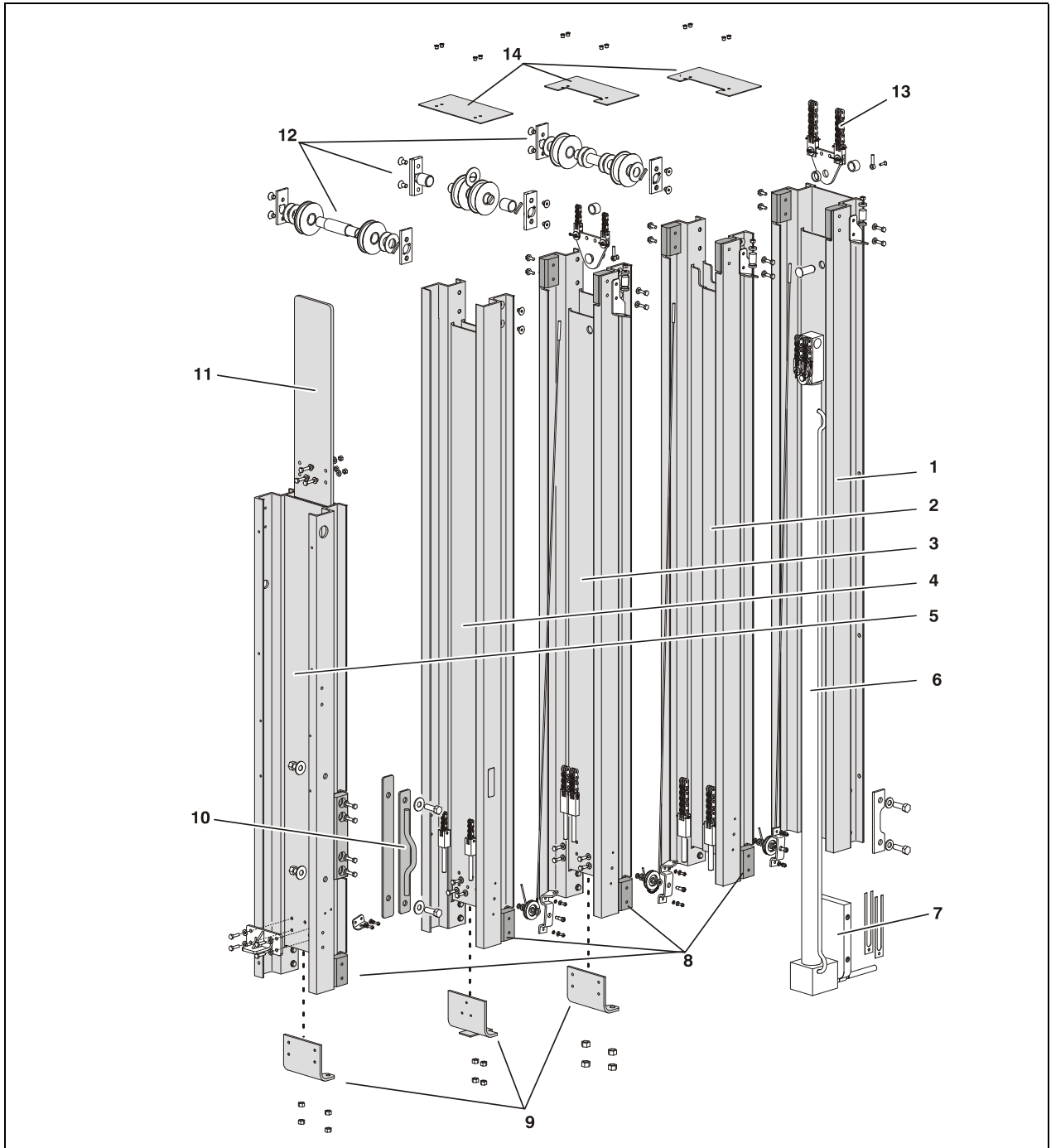

Figure 5-1. Mast Components. (MVL/MSP)

- | | | | | |
|---------------------|---------------------|------------------------|-----------------------|---|
| 1. Mast Section - 1 | 4. Mast Section - 4 | 7. Lift Cylinder Mount | 10. Lanyard Attach | 13. Chain/Equalizer -
Plate Assemblies |
| 2. Mast Section - 2 | 5. Mast Section - 5 | 8. Slide Pads | 11. Chain Guard | |
| 3. Mast Section - 3 | 6. Lift Cylinder | 9. Chain Anchor Plates | 12. Sheave Assemblies | 14. Mast Mini Covers |

5.2 MAST CHAINS AND SEQUENCING CABLES ADJUSTMENT

Mast Chain/Cable Adjustment

The intention of this procedure is to assure equal load distribution between the individual chains of a mast section chain sets. Also to step each front mast section up approximately 7/16 in. (12mm) from the section behind it to allow clearance for the individual mast section covers.

Adjust using the following procedure;

1. With mast retracted, step into the platform and bounce your weight up and down a few times to be certain platform is at the bottom of travel. Be certain all chain/cable sets are seated in their sheaves properly at the top of each mast section.
2. Then with no load in the platform check the side profile of the top of the mast for the amount of adjustment necessary to obtain the 7/16 in. (12mm) step for mast sections-3 and up. (See *Illustration*)

NOTE: Mast section-1 is fixed to the base and mast section-2 is attached to the lift cylinder, these sections require no adjustment.

3. Adjust one mast section at a time starting from the back (*section-3, section-4, etc.*) of the mast and work forward. (*i.e. if three is OK, then jump to four, etc.*)
4. To adjust, elevate the platform until the chain/cable anchor adjust nuts are accessible at the front and bottom of each mast section.

WARNING

NEVER WORK UNDER AN ELEVATED PLATFORM UNTIL PLATFORM HAS BEEN SAFELY RESTRAINED FROM ANY MOVEMENT BY BLOCKING OR OVERHEAD SLING.

5. Start with the mast section which needs adjustment and loosen the bottom (*jam*) nut on each chain/cable.

6. **Tighten** (*to raise mast section*), or **loosen** (*to lower mast section*) the **adjusting nut** against the anchor plate on each chain/cable. Adjust the nut the amount required to raise or lower the top of the mast section to match the side profile shown in Figure 5-2. when the mast is retracted.

NOTE: *It is more important that the (threaded ends) studs protruding on the adjustments are equal side to side on a mast section, than it is that the tension in the chains is equal. The chain equalizers will always assure equal tension, but if the adjustment isn't equal as described, the chains may tend to pull to one side or the other.*
The threaded end of the chain/cable may need to be restrained while tightening the adjust nut to keep the chain/cable from twisting.

7. Retract the mast all the way and check if the top of the mast sections appear as shown in Figure 5-2.
8. Repeat steps (1) through (7) for remaining mast sections.
9. Once mast section adjustment is completed, apply loctite #242 to the threads under the (*jam*) nuts that were loosened. Then re-tighten the loosened (*jam*) nuts until tight against the top (*adjust*) nut. Chain/cable should have slight tension but should not be taut.
10. **(MSP Only)** After all mast adjustments are complete, if necessary adjust the bumpers on the underside of the stock-picker platform so the platform rests slightly above the base frame when it is lowered and empty.

Sequencing Cable Adjustment

1. Retract mast completely, and check each sequencing cable on outside of masts for excessive slack. Adjust only to remove slack from cable.
2. Tighten nylock-nut just enough to remove excessive slack from sequencing cable. The springs should not be compressed more than 25% after adjusting.
3. Run mast through several cycles to verify cable/chain adjustments and ensure no interference exists between chain anchor brackets and mast.

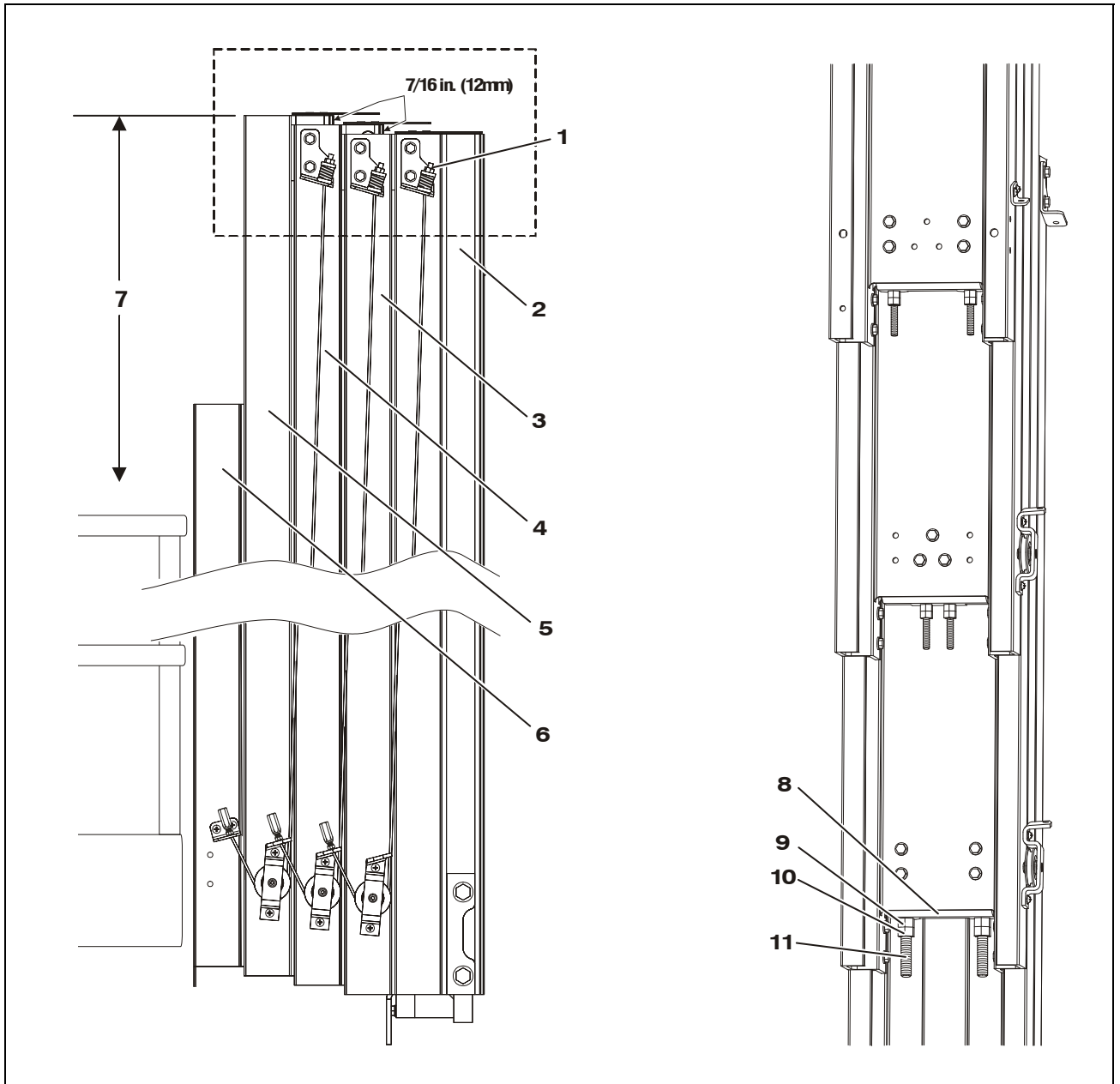

Figure 5-2. MVL/MSP - Mast Chain and Sequence Cable Adjustment Components.

- | | | | |
|------------------------------|---------------------|-----------------------------|------------------------|
| 1. Sequence Cable Adjust Nut | 4. Mast Section - 3 | 7. Check Mast Stowed Height | 10. Chain Lock Nut |
| 2. Mast Section - 1 | 5. Mast Section - 4 | 8. Chain Anchor Plate | 11. Threaded Chain End |
| 3. Mast Section - 2 | 6. Mast Section - 5 | 9. Chain Adjust Nut | |

5.3 SEQUENCE CABLE REPLACEMENT KIT

A sequence cable replacement kit is available from the JLG Parts Department to service broken or worn sequence cables. This kit consists of a replacement sequence cable with the threaded (top) end attached same as the top end of the factory cable. Also included is a clamp (drum/socket type) to secure the bottom end of the cable. Use the following procedure to install the replacement cable and clamp kit.

Remove Old Cable

1. Remove the locking nut from the threaded end of the cable at the top of the mast and then remove the spring cap, spring, and spacer washers if installed.
2. Slide the threaded top end out of the upper anchor bracket, then at the bottom end pull the cable out through the sheave pulley/anchor bracket until it is completely clear of the machine.

Replacement Cable Installation

1. Be certain the mast is completely retracted and at the bottom of travel. Check the mast "Side Profile" at the top of the mast as shown in Figure 5-2., adjust mast sections to proper height if necessary.
2. To determine where the clamp will be installed at the bottom of the replacement cable, temporarily assemble the new replacement cable to the top cable anchor bracket on the mast using the washers, spring, spring cap and lock nut previously disassembled. Thread the lock nut on until approximately 1/8 in. (3mm) of threads are exposed.
3. At the bottom of the mast, thread the loose end of the replacement cable through the proper sheave pulley and through the hole in the sheave pulley/anchor bracket on the mast section ahead of the sheave pulley.
4. Grasp the cable and pull on the cable until the spring at the top of the cable is slightly compressed. Use a black marker to mark the cable on the top side of the sheave pulley/anchor bracket. This will determine where the clamp (drum/socket) sleeve will be positioned on the cable.

NOTICE

DO NOT CUT THE CABLE AT THE MARKED POINT ON THE CABLE THIS IS ONLY USED AS A REFERENCE FOR POSITIONING THE CABLE SLEEVE WHICH WILL REST AGAINST THE ANCHOR BRACKET ONCE INSTALLED.

Clamp Installation (Drum/Socket Type)

NOTICE

THE MANUFACTURER OF THE DRUM/SOCKET CLAMP RECOMMENDS THE USE OF THEIR CABLE CLAMP ASSEMBLY KIT (JLG P/N - 7023275) TO ASSEMBLE THE CLAMP TO THE WIRE ROPE. THE KIT CONSISTS OF VISE JAWS TO HOLD THE WIRE ROPE IN A VISE PROPERLY WITHOUT DAMAGING ANY ROPE STRANDS AND A PLUG DRIVER TO DRIVE THE PLUG INTO THE CENTER OF THE WIRE ROPE AND IS ALSO USED TO FORM THE STRANDS OF THE ROPE DURING ASSEMBLY.

NOTE: The tools in the clamp assembly kit may be fabricated if necessary. The vise clamp consists of vise jaws with a hole drilled 1/32 in. smaller than the diameter of the wire rope you are working with (i.e. 1/8 in. rope - 3/32 in. hole.)

The plug driver is a metal tube with a hole in the bottom to allow the strands of the wire rope to be shaped after the plug has been tapped into the center of the wire rope.

1. Using the recommended vise jaws, clamp the wire rope into a vise with the bottom edge of the black mark made on the wire rope resting just above the vise jaws.

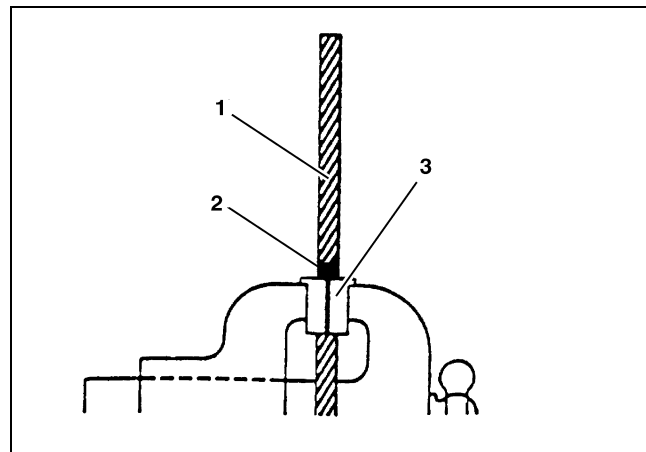

1. Cable
2. Mark on Cable
3. Recommended Vise Jaws

- Twist the sleeve from the clamp kit onto the rope until it is flat against the vise jaws at the mark made on the wire rope.

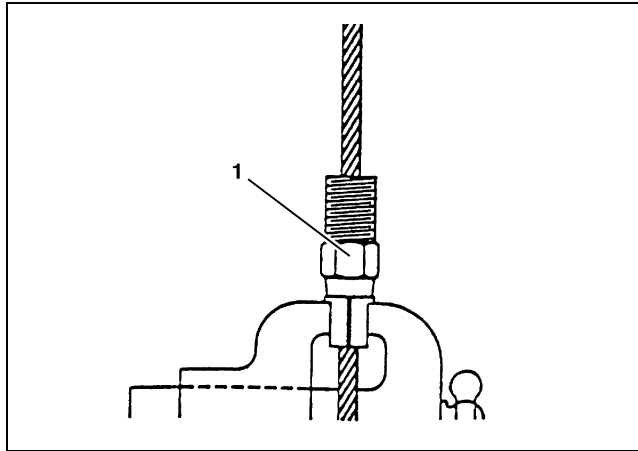

1. Sleeve Installed on Cable

- Use a suitable tool and cut the cable as shown in the illustration following. For 1/8 in. cable the recommended length is 5/8 in. past the end of the sleeve.

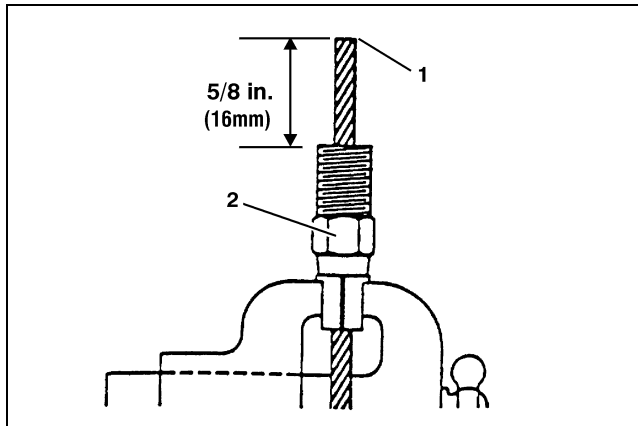

1. Cut To This Length 2. Sleeve

- Unlay the cable strands by gently forcing a screwdriver between the outer strands to unlay the cable. When done properly the outer strands will form a symmetrical basket. Do not straighten out the spiral lay of the strands, unlay any wires that make up the strand, or allow the strands to cross each other inside the sleeve.

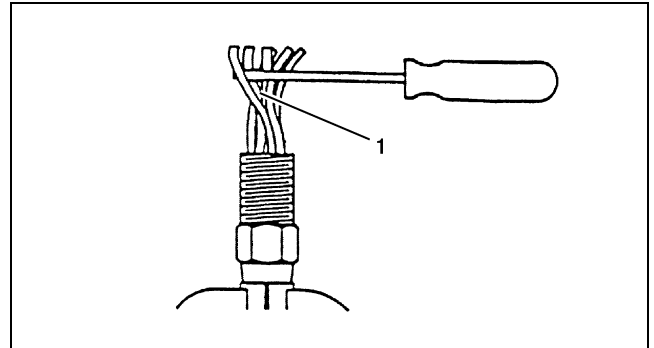

1. Cable Strands Unlayed

- Install the plug supplied with the kit by placing the plug in the center of the strands starting with the small tapered end of the plug. Use a metal tube (plug driver) and hammer to drive the plug into the sleeve while assuring that the strands are spaced somewhat equally around the plug. Drive the plug until it is firmly seated and no more than 1/3 of the plug is visible from above the sleeve.

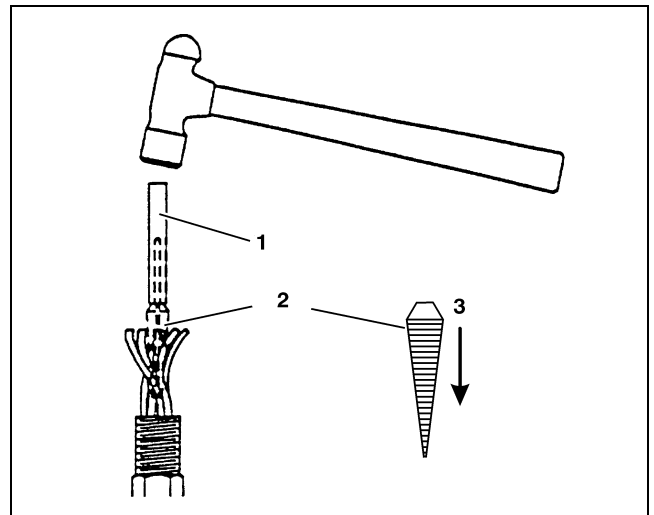

1. Plug Driver 2. Plug 3. Insert Plug in this Position

SECTION 5 - MAST COMPONENTS

6. Reclamp the assembly in the vise on the flats of the sleeve. Using the plug driver, a metal tube or pliers, bend the outer strands toward the center strands enough that the socket can be slipped over all the strands.

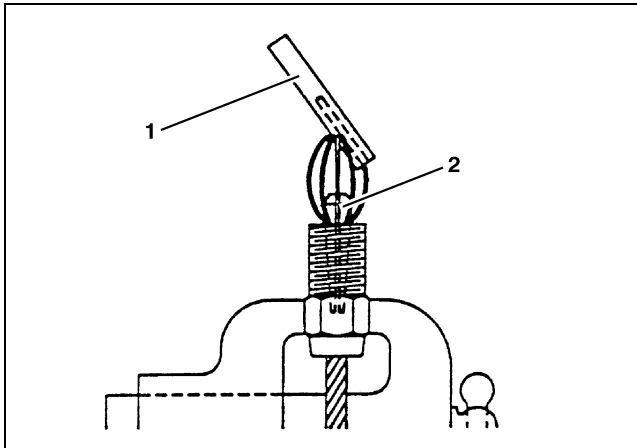

1. Use Plug Driver, Metal Tube or Pliers
2. Shape Strands Around Plug

NOTE: When assembling stainless steel parts all threads must be coated with a dry lubricant or an anti-seize lubricant to prevent seizing.

7. Coat the threads of the socket and sleeve with lubricant and install the socket by twisting it over the strands of the cable and engage the threads of the sleeve with the socket. Tighten until four threads or fewer are visible. If more than four threads are visible, proof load the cable and retighten the socket fitting. (There is no specific requirement for torque.)

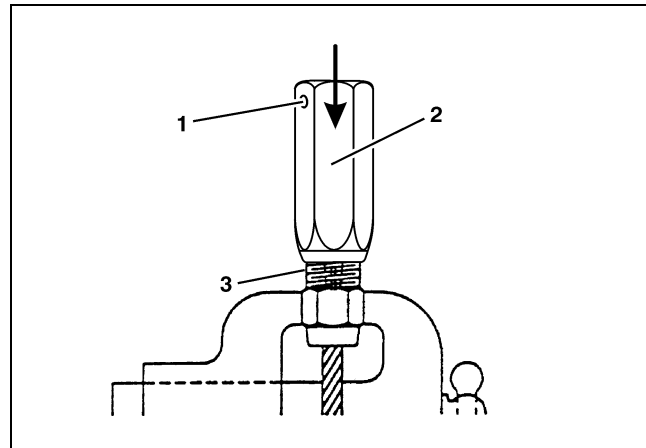

1. Inspection Hole
2. Install Socket and Tighten
3. Four Threads or Less Showing

8. Inspect for proper assembly prior to loading the cable. Strands visible through the inspection hole are your assurance of a proper assembly.

NOTE: The end of the rope may not be visible in the inspection hole after loading.

9. Install cable on machine and adjust per instructions shown previously in Section 5.2, MAST CHAINS AND SEQUENCING CABLES ADJUSTMENT.

5.4 HYDRAULIC LINE - DISCONNECT - SPECIAL TOOL

The extend and return hydraulic line couplings and hose fittings on this machine require special tool JLG P/N-7027247 to remove and install them.

⚠ CAUTION

FULLY LOWER THE MAST TO RELIEVE PRESSURE IN THE SYSTEM BEFORE REMOVING ANY HYDRAULIC LINES. CAREFULLY LOOSEN REQUIRED FITTINGS, WEAR SAFETY PROTECTION EQUIPMENT WHEN WORKING WITH HYDRAULIC SYSTEMS.

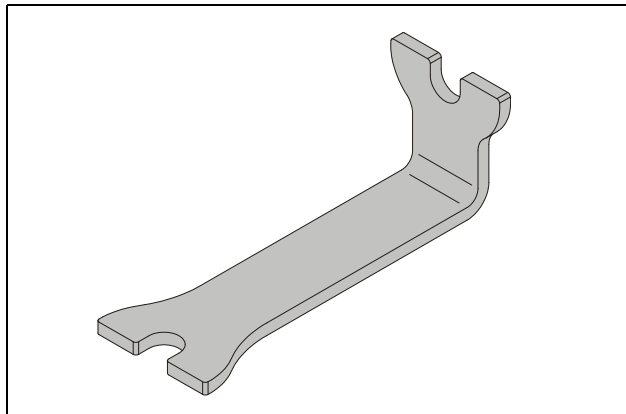

Push Type Hydraulic Line Removal - SpecialTool
JLG P/N - 7027247

Instructions for tool use on both in-line and angled hose fittings are shown on the pages following.

Tool Use - In-Line Style Fittings



Step 1. Prior to disconnection, ensure that system is not under pressure.

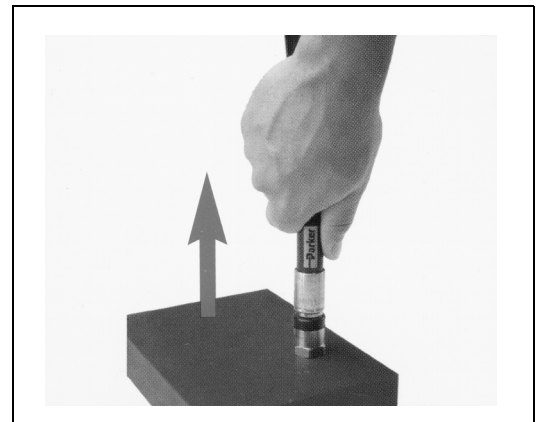

Step 2. Pull on hose assembly to create a gap between the dust boot and hose fitting shoulder.

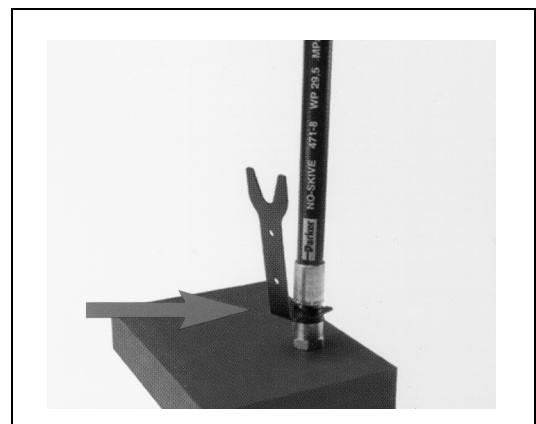

Step 3. Insert the disconnect tool in the gap created between the dust boot and hose fitting shoulder.

Tool Use - In-Line Style Fittings (continued)

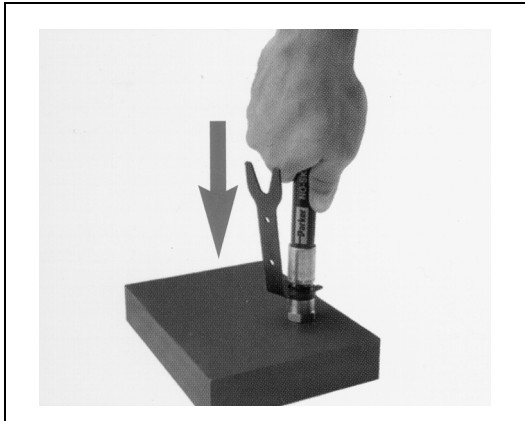

Step 4. Gently push hose assembly into coupling body (see directional arrow).

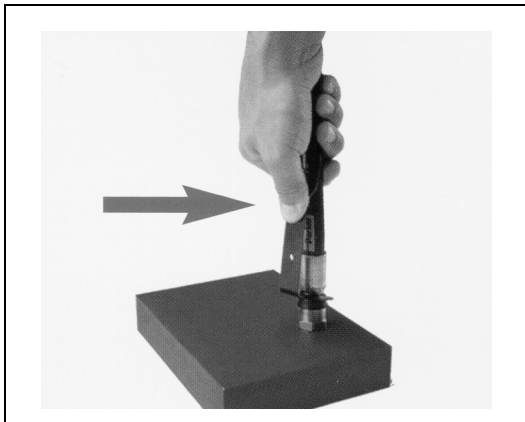

Step 5. Maintaining slight pressure on the hose assembly, actuate the tool (see arrow).

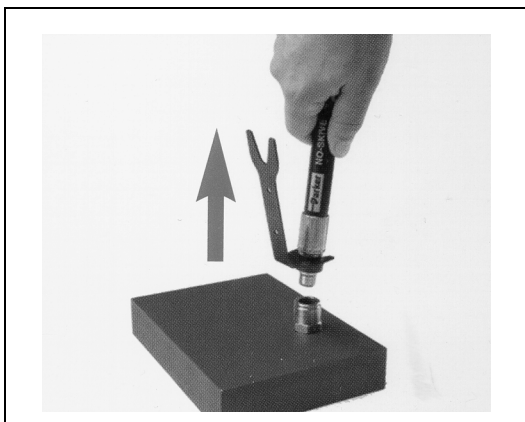

Step 6. Release the tool and pull on hose assembly to complete disconnection.

Tool Use - Angled Style Fittings

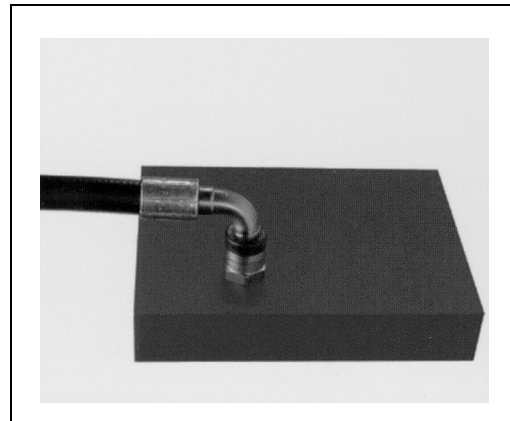

Step 1. Prior to disconnection, ensure that system is not under pressure.

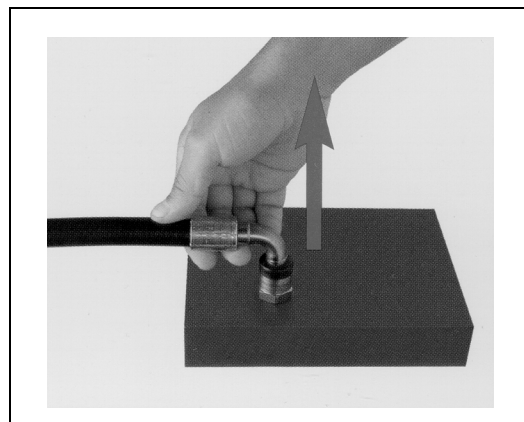

Step 2. Pull on hose assembly to create a gap between the dust boot and hose fitting shoulder.

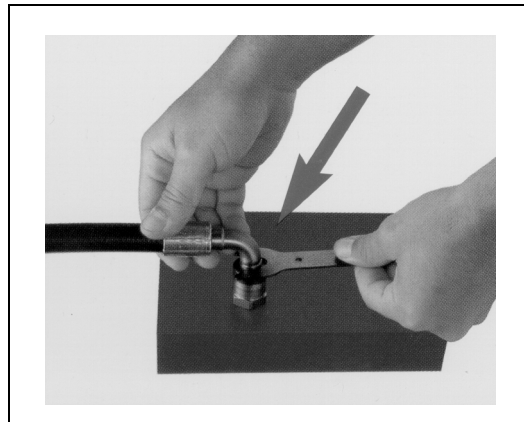

Step 3. Insert the disconnect tool in the gap created between the dust boot and hose fitting shoulder.

Tool Use - Angled Style Fittings (continued)

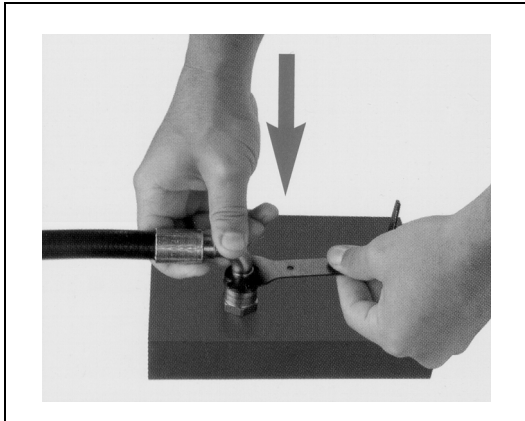

Step 4. Gently push hose assembly into coupling body (see directional arrow).

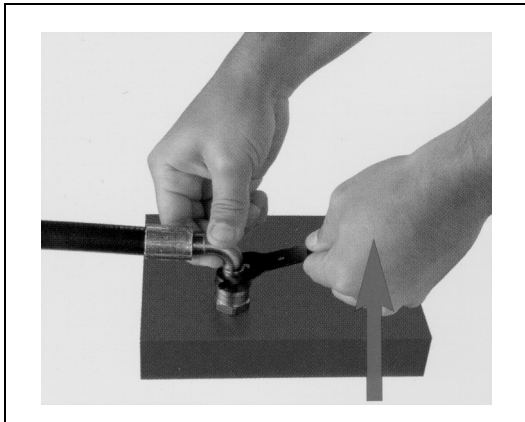

Step 5. While maintaining slight pressure on the hose assembly, actuate the tool (see arrow).

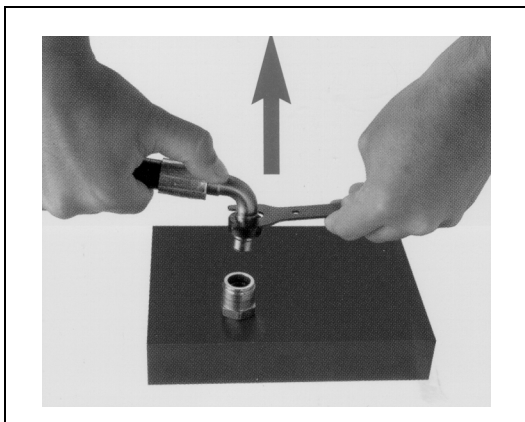

Step 6. Pull on hose assembly to complete disconnection.

5.5 HYDRAULIC LIFT CYLINDER - REMOVAL, INSPECTION AND REBUILD

⚠ WARNING

HYDRAULIC CYLINDERS ARE DESIGNED TO HOLD HYDRAULIC FLUID UNDER HIGH PRESSURE. ENSURE ALL APPROPRIATE MEASURES ARE TAKEN TO RELIEVE RESIDUAL PRESSURE IN THE CYLINDER BEFORE DISCONNECTING LINES.

Lift Cylinder Removal

Removal of the hydraulic lift cylinder without removing the mast from the machine requires laying the machine on it's back (hood side) with the platform end on top.

1. Remove the following components from the machine before laying machine on it's back:
 - Rear Covers (See Section 4)
 - Batteries (See Section 3)
 - Drive Motor Cover (See Section 3)
2. Seal the vented cap on the hydraulic fluid reservoir by removing the cap, covering the hole with a few layers of plastic wrap or equivalent. Then install and tighten the cap over the plastic wrap to prevent leakage of hydraulic oil from the reservoir while machine is in a layed back position.
3. Use a forklift truck or overhead crane and carefully lay the machine on it's back, place a support under the mast end, keeping mast close to level. (See Figure 5-3.)

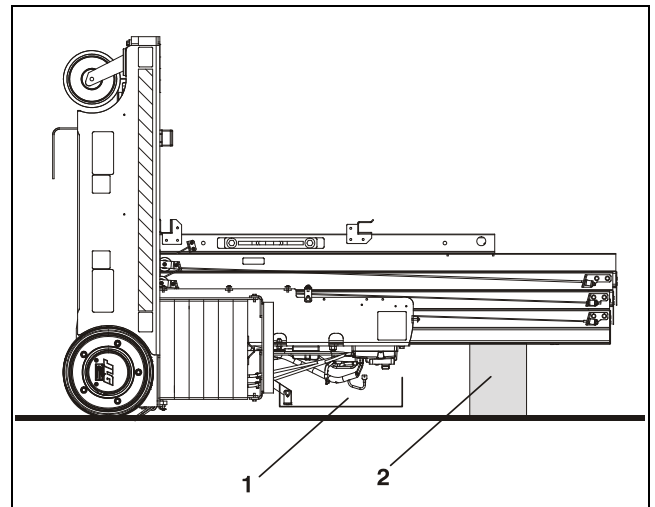
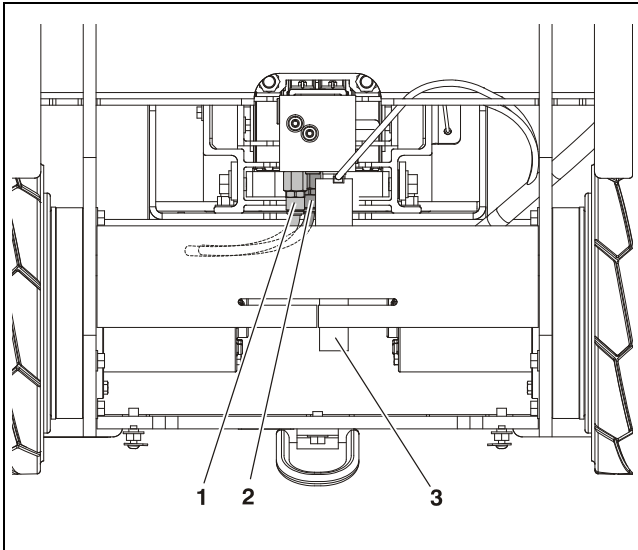

Figure 5-3. Machine Positioned for Cylinder Removal.

1. Be Careful of Control Components in this Area
2. Support Mast Here - Keep Mast Approximately Level

SECTION 5 - MAST COMPONENTS

- At the base end, remove and cap the extend and return hydraulic lines.



Hydraulic Extend and Return Lines

- Cylinder Return Line
- Cylinder Extend Line
- Manual Descent Valve

- Remove the mini covers from the tops of the mast sections.
- Manually extend the mast assembly until the top of mast section-2 is extended approximately one (1) foot (31cm), to allow access to the sheave wheel-anchor block at the top of mast section-2 and the lift cylinder.

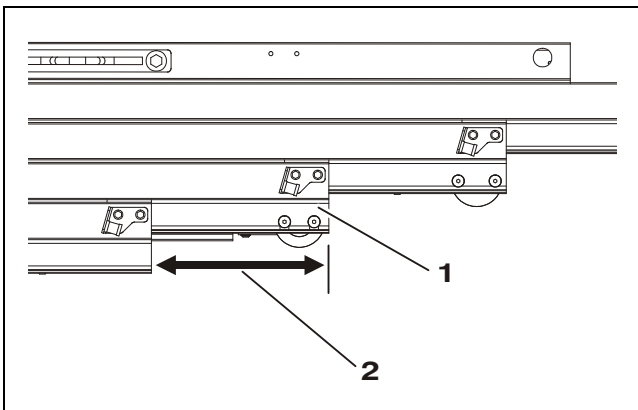

Extending Mast Sections

- Mast Section-2
- 1 ft. (31cm) Extended

- Remove the adjust and lock nuts from the chain studs at the bottom of mast section-3.

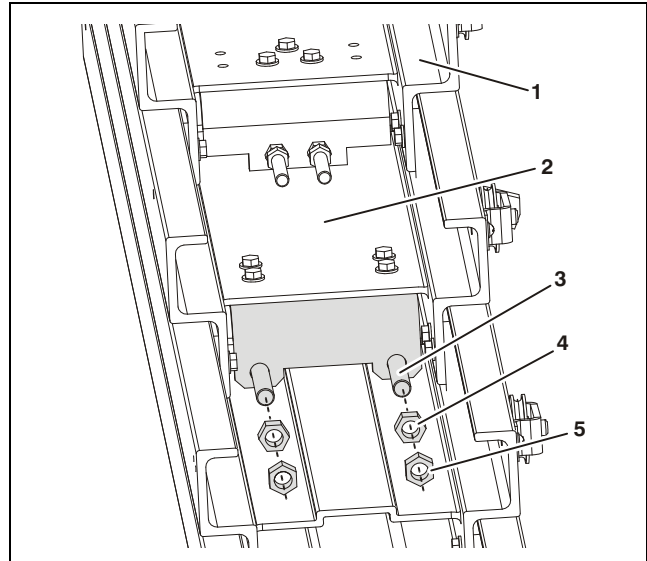

Chain Assembly - Bottom of Mast Section-3

- Mast Section-4
- Mast Section-3
- Chain Assembly Stud (a)
- Adjust Nut
- Lock Nut (b)

Note: (a) Remove nuts and push studs through anchor plate.

- Push mast sections-3, 4 and 5 back towards the base assembly allowing the top of mast section-2 to be completely exposed.

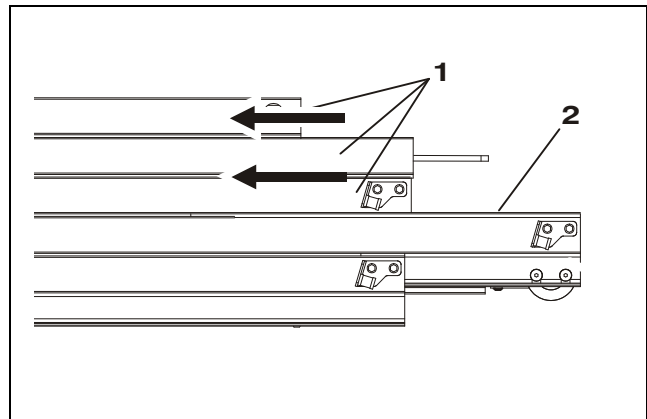

Exposing Top of Mast Section-2

- Sections-3, 4 and 5 Pushed Back
- Top of Mast Section-2 Exposed

9. Remove the cylinder/anchor block attach pin - snap ring from the back of the top of mast section-2.

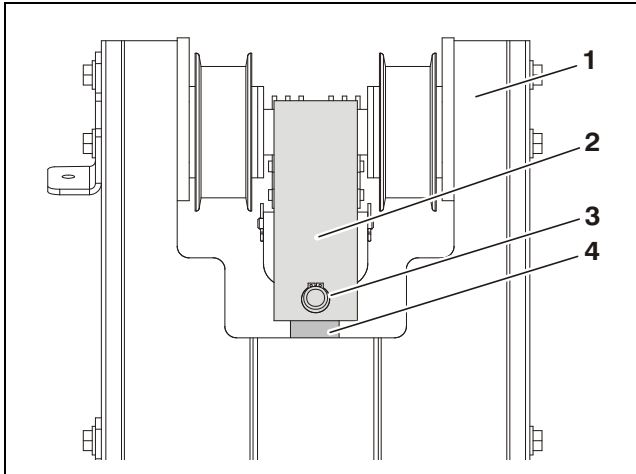

Snap Ring Installation

- | | |
|----------------------------|----------------------|
| 1. Back of Mast Section-2 | 3. Pin and Snap Ring |
| 2. Cyl./Chain Anchor Block | 4. Cylinder Rod |

10. Remove the cylinder rod pin from the cylinder/chain anchor block.

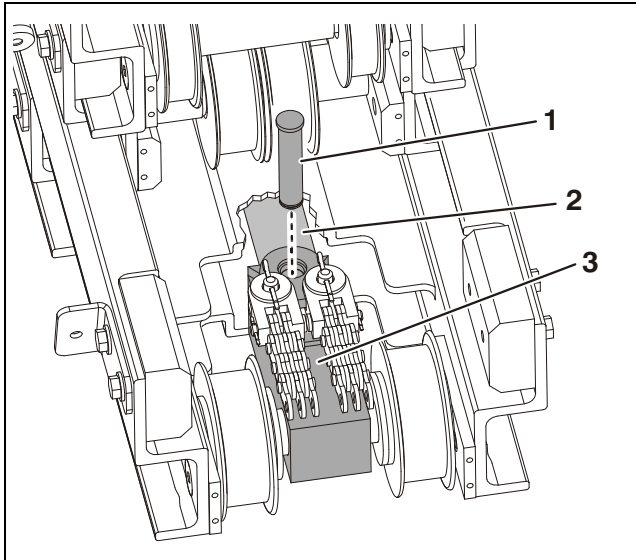

Cylinder Rod Pin Installation

- | | |
|---------------------|----------------------------|
| 1. Cylinder Rod Pin | 3. Cyl./Chain Anchor Block |
| 2. Cylinder Rod | |

11. At the bottom of mast section-1, remove the cylinder mount bolts, and mount reinforcement plates.

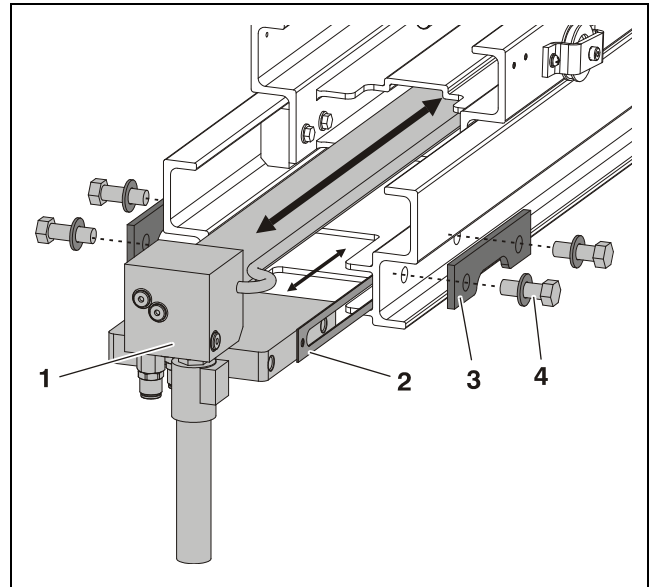

Lift Cylinder Mount Installation

- | | |
|-----------------------------|--------------------------------|
| 1. Cylinder/Mount Assembly | 3. Mast Reinforcement Plate |
| 2. Mount Shims (Mark Shims) | 4. Mounting Screws/Washers (a) |

Notes: (a) Apply Loctite #242 to threads at final assembly.

NOTE: If mount shims are installed, mark the mast and the shim to which side the shims came out of for re-installation.

12. Slide the lift cylinder and mount assembly out of the bottom of mast section-1 and -2 and place on a suitable work surface.

Cylinder Disassembly

(See Figure 5-4.)

1. Before disassembling the cylinder, clean away all dirt and foreign substances from openings, particularly the head area.

NOTE: Always protect the chrome surface of the cylinder rod during assembly and disassembly. Any damage to this surface will require replacement of the rod.

2. Extend the rod until the piston bottoms out against the cylinder head.
3. Compress the head restraining ring enough to allow the cylinder head to be removed.
4. Carefully slide the head/rod/piston assembly out of the cylinder tube. A gentle tap on the head assembly may be required to remove the head from the cylinder tube.
5. Place the head/rod/piston assembly on a surface that will not damage the chrome.
6. Remove the piston locknut and separate the piston from the rod.
7. Slide the head off the rod from the piston end.

NOTE: When removing the old seals use only blunt tools, be sure there are no sharp edges that may damage the seal grooves during removal. Scratching the groove may cause by-pass.

8. Remove and discard all old seals.

Lift Cylinder Component Inspection

Cylinder Rod

There should be no scratches or pits deep enough to catch the fingernail. Pits that go to the base metal are unacceptable. Scratches that catch the fingernail but are not to the base metal, less than 0.5 inch long and primarily in the circumferential direction are acceptable provided they cannot cut the rod seal. Chrome should be present over the entire surface of the rod and the lack thereof is unacceptable. In the event that an unacceptable condition occurs, the rod should be repaired or replaced.

Cylinder Head

Visually inspect the inside bore for scratches or polishing. Deep scratches are unacceptable. Polishing indicates uneven loading and when this occurs, the bore should be checked for out-of-roundness. If out-of-roundness exceeds 0.007", this is unacceptable. Check the condition of the dynamic seals (wiper, rod seals) looking particularly for metallic particles embedded in the seal surface. It is normal to cut the static seal on the retaining ring groove upon disassembly. Remove the rod seal, static o-ring and backup and rod wiper. Damage to the seal grooves, particularly on the sealing surfaces, is unacceptable. In the event that an unacceptable condition occurs, the head should be replaced.

Piston

Visually inspect the outside surface for scratches or polishing. Deep scratches are unacceptable. Polishing indicates uneven loading and when this occurs, the diameter should be checked for out-of-roundness. If out-of-roundness exceeds 0.007", this is unacceptable. Check the condition of the dynamic seals and bearings looking particularly for metallic particles embedded in the bearing and in the piston seal surface. Remove the seals and bearings. Damage to the seal grooves, particularly on the sealing surfaces, is unacceptable. In the event that an unacceptable condition occurs, the piston should be replaced.

Tube Assembly

Visually inspect the inside bore for scratches and pits. There should be no scratches or pits deep enough to catch the fingernail. Scratches that catch the fingernail but are less than 0.5 inch long and primarily in the circumferential direction are acceptable provided they cannot cut the piston seal. The roughness of the bore should be between 10 and 20 μ inches RMS. Significant variation (greater than 8 μ inches difference) are unacceptable. In the event that an unacceptable condition occurs, the tube assembly should be repaired or replaced.

Cylinder Assembly (See Figure 5-4.)

1. Rinse the inside of the tube with hydraulic fluid and allow to drain. A high-pressure rinse followed by a wipe with a lint-free rag is preferable. Clean all internal components of any foreign material.
2. Lubricate the head and all seals with hydraulic fluid prior to installation. Install the seal, wiper, o-ring, back-up ring, and retraining ring to the cylinder head.
3. Lubricate the piston and all components with hydraulic fluid. Install the seal and wear ring to the piston.

NOTE: Re-check that seals are not twisted or pinched and are properly seated.

4. Place the rod on a clean table. Install the static piston o-ring seal into the groove on the piston end of the rod.
5. Install the head followed by the piston onto the rod noting the proper orientation of each component. Torque the piston nut to 100-120 ft. lbs.
6. When the rod assembly is ready to be installed into the tube, liberally apply an anti-seize lubricant to the cylinder head surface which slides into the cylinder tube.
7. Next dip the entire rod assembly into hydraulic fluid and stuff this assembly into the tube. Watch the seals as they pass over the rod port (if visible) to be sure they are not nicked or cut.
8. Install the head until the retaining ring seats in it's groove.

Cylinder Installation

To install the lift cylinder reverse the Lift Cylinder Removal instructions at the start of this section, however perform the following additional steps during re-assembly.

1. Apply Loctite #222 (purple) and torque to 85 ft. lbs. the cylinder mount shoulder screws securing the lift cylinder mount halves together at the bottom of the mast.
2. Check that the platform electrical control cables and the sequence cables are seated in their sheave wheel assemblies when extending mast sections for reassembly.
3. After assembly, readjust the chain at the bottom of mast section-3 and apply Loctite #242 to the lock nuts before final tightening.
4. Remove the plastic from under the hydraulic reservoir tank cap.

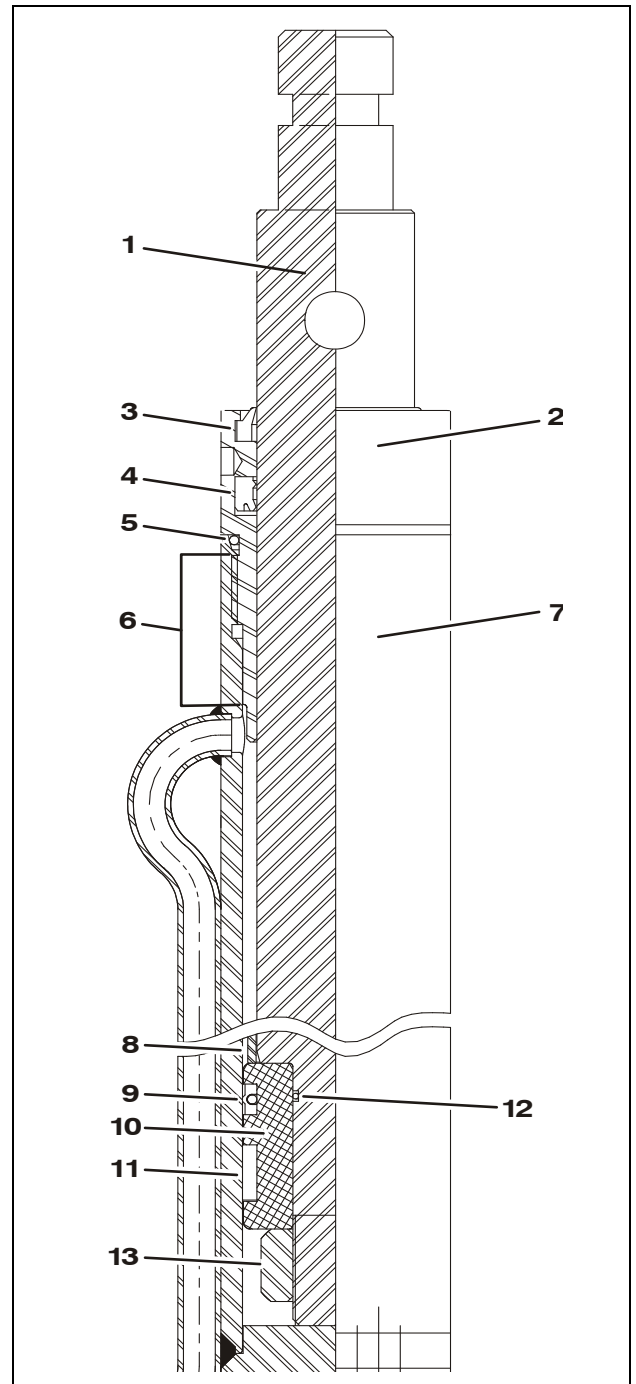
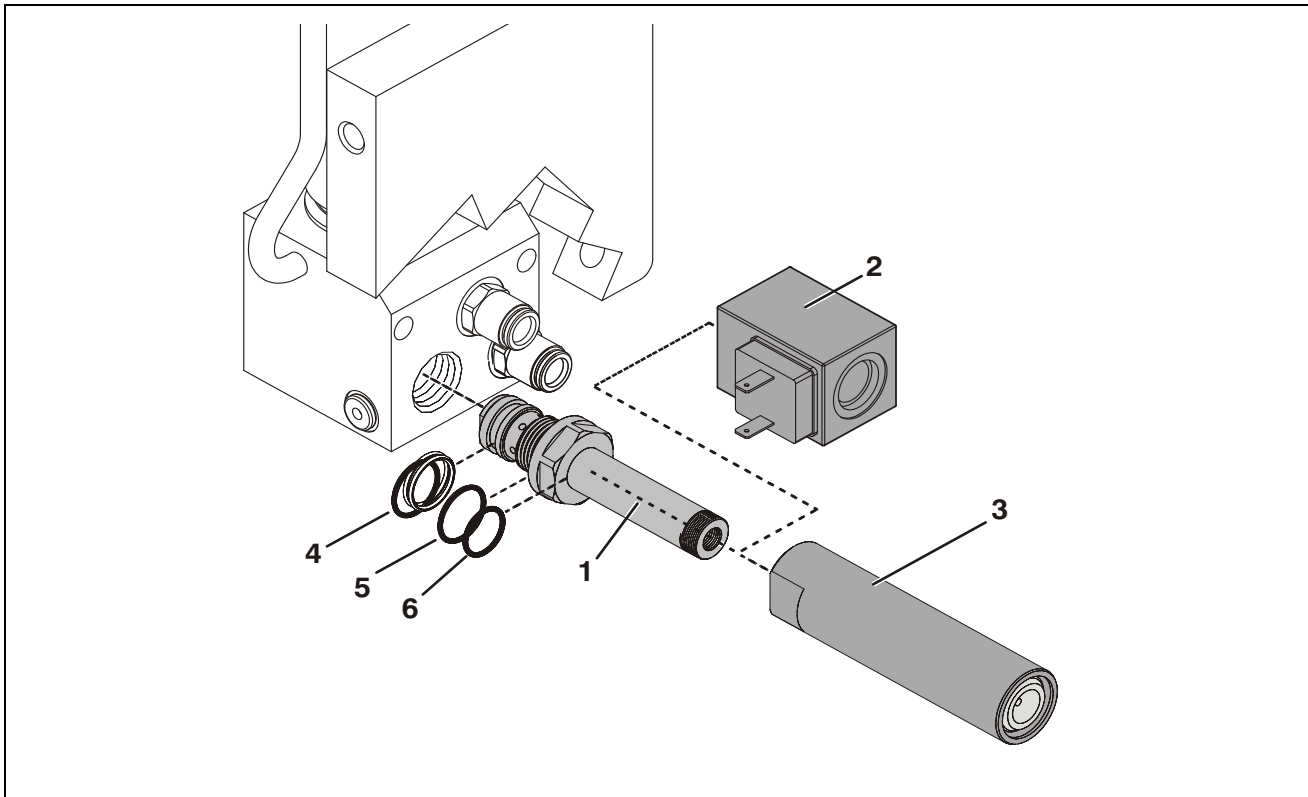

Figure 5-4. Lift Cylinder Component Cross-Section (MVL/MSP).

- | | | |
|------------------|---------------------|-------------------------|
| 1. Cylinder Rod | 6. Apply Anti-Seize | 10. Piston |
| 2. Cylinder Head | 7. Cylinder Tube | 11. Wear Ring |
| 3. Rod Wiper | 8. Spacer | 12. Piston O-Ring |
| 4. Rod Seal | 9. Piston Seal | 13. Piston Lock Nut (a) |
| 5. O-Ring | | |

Note: (a) Torque 100 - 120 ft. lbs.



Lift Down Valve and Manual Release Installation

- | | |
|----------------------------|----------------------------------|
| 1. Lift Down Valve (a) | 4. O-Ring with Backing Rings (a) |
| 2. Valve Solenoid (b) | 5. Valve O-Ring (a) |
| 3. Manual Release Assembly | 6. Solenoid O-Ring (a) |

Notes: (a) Coat all o-rings with clean hydraulic fluid before assembling.
(b) Mount with electrical terminals pointing to right side of machine.

5.6 MAST ASSEMBLY INSTALLATION

Mast Removal

1. The following components must be removed from the machine before removing the mast assembly:
 - Rear Covers
 - Drive Motor Cover
 - Disconnect the Platform Control Console from the Mast mounted junction box
 - Platform Assembly
2. Disconnect the positive battery cable from the left side battery.
3. Unplug the platform control cable connector at the ground control module.
4. Remove the clamp attaching the platform control cable from inside the mast mounting column.
5. Disconnect the spring and clamp attaching the AC receptacle cable inside the mast mounting column.
6. Under the machine, disconnect and cap the hydraulic extend and return lines from the hydraulic cylinder.
7. Using an overhead crane or suitable lifting device capable of supporting the weight of the mast assembly, attach a sling strap to the mast. *(If installed, use the optional crane lifting lug on the back of the mast.)*
8. Remove the six (6) mast attach bolts with washers and nuts securing the mast to the mounting column.
9. Lift the mast off the base frame and place on a suitable work surface.

Mast Installation

To install the mast assembly reverse the Mast Assembly Removal instructions, however perform the following additional steps during re-assembly.

1. Install machine covers per instructions Section 3.
2. Once assembly is complete cycle the mast up and down several times, then check the oil level in the hydraulic reservoir.

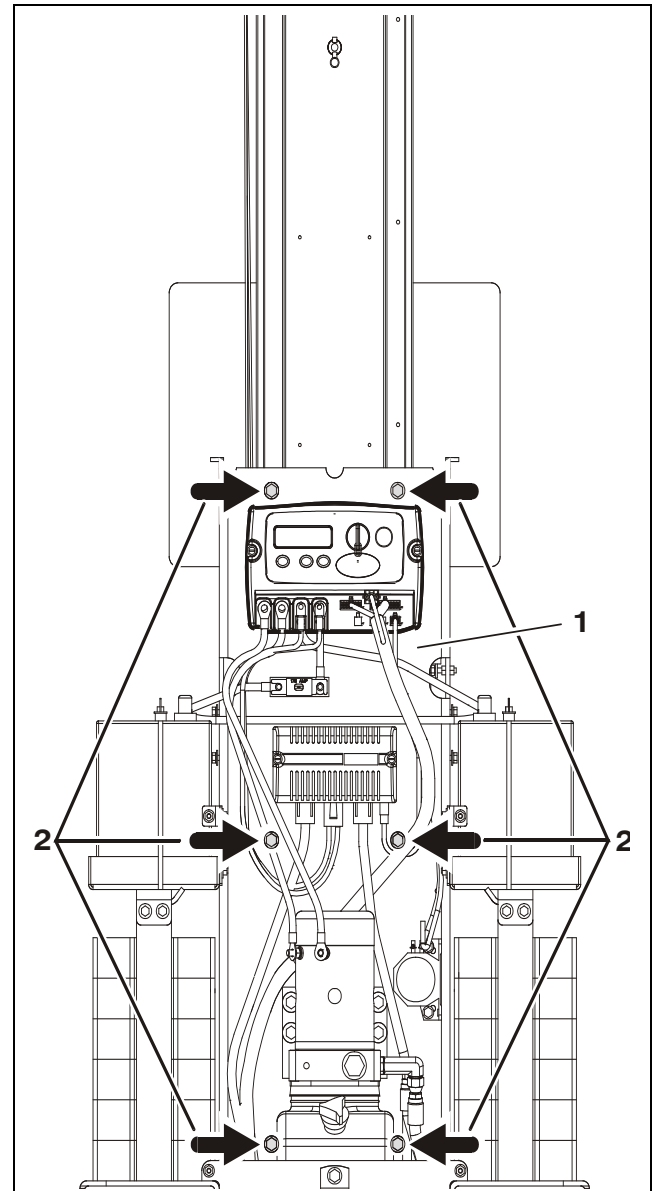

Mast Assembly Installation

1. Mast Mounting Column
2. Mounting Bolt/Washer/Nut Locations (a)

Notes: (a) Apply Loctite #271 to bolt threads on final assembly.

5.7 MAST ASSEMBLY AND DISASSEMBLY PROCEDURES

The MVL/MSP lift mast sections are constructed of extruded aluminum, protected with an anodized surface finish. The mast sections are interlocked into each other when assembled, by internally mounted slide pads at the top and bottom of each mast section. These slide pads run up and down in slide pad channels on each side of the mast.

The MVL/MSP model mast assembly contains a different number of mast sections as shown following;

Table 5-1. MVL/MSP Mast Component Features

Model	No. of Mast Sections	Extend/Retract Device
MVL Series & MSP	5	Chain

Assembly procedures for all mast sections is basically the same, carefully slide the mast sections together until mast ends are even. *(When sliding the mast sections together, be careful not to scratch the anodized surface).* Assemble the hardware to the bottom of mast section first, slide this section out the top of previous section and assemble hardware to the top of mast. Always install slide pad shims with slide pads inserted into the slide pad channels, *(ends of mast sections even).* Applying silicone spray onto the

slide pads and slide pad channels before assembly will help mast sections slide easier after slide pads have been properly shimmed.

Mast Disassembly Procedure

1. After the mast assembly has been removed from the machine, lay the mast assembly down on a suitable work table with the platform mounting section on top, facing up.
2. Remove the sequencing cables and hardware from the sides of the mast assembly. Also remove the covers from the top of the mast assembly.

Mast Section-5 - Removal

3. Remove chain adjust nuts from threaded ends of chain attached to the chain anchor plate (*lower*) on BOTTOM end of mast section-5 (*platform mounting section*). Push threaded ends of chain through anchor plate.
4. At the TOP of mast section-5, pull chains out and allow to hang loose. *(Be certain floor surface is clean and free of any metal chips or debris which may stick to lubricated chains).*

NOTE: When sliding mast sections apart, be careful not to scratch or score the anodized surface in the slide pad channels.

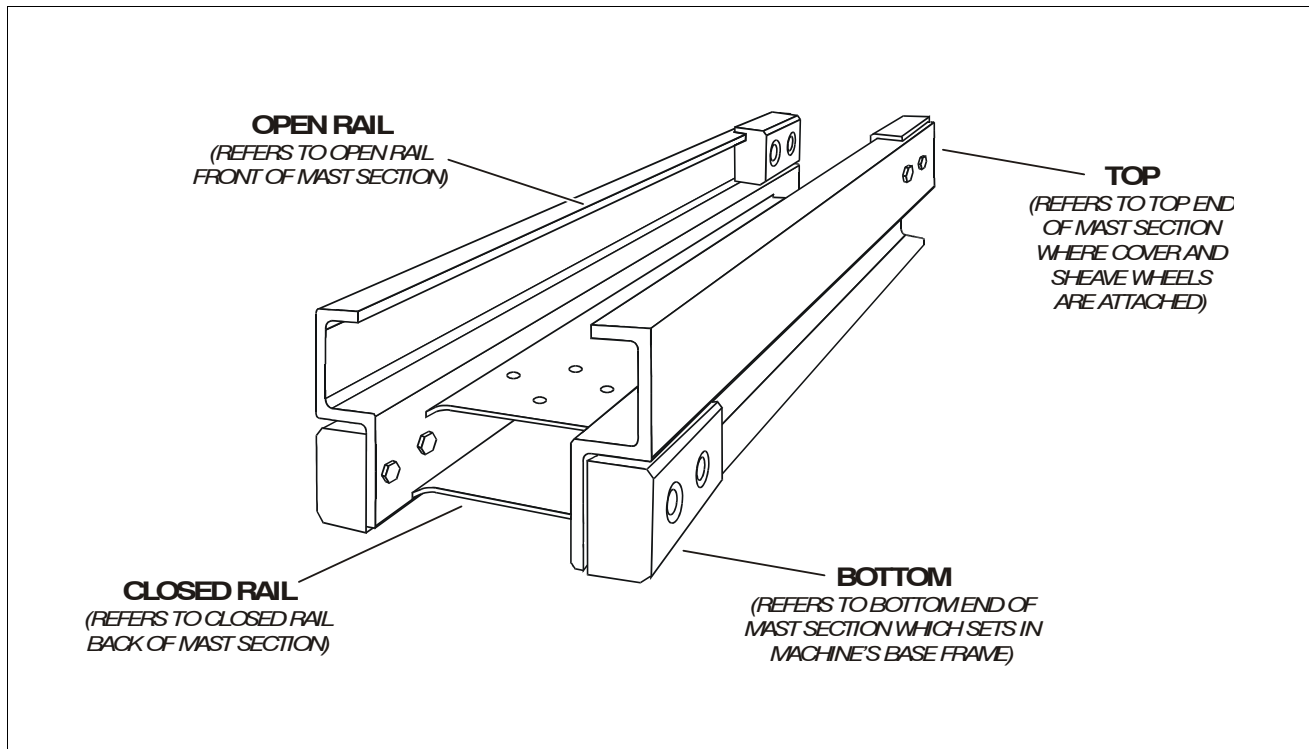

Figure 5-5. Mast Section - Assembly Reference.

5. Carefully slide mast section-5 out the BOTTOM of mast section-4 rails. Disassemble slide pads, shims and chain anchor plate from mast section-5, if necessary.

Mast Section-4 - Removal

6. Remove chain adjust nuts from threaded ends of chains attached to the chain anchor plate (lower) on BOTTOM end of mast section-4. Push threaded ends of chains through anchor plate.
7. At TOP of mast section-4, pull chains out and allow to hang loose. *(Be certain floor surface is clean and free of any metal chips or debris which may stick to lubricated chains).*
8. Slide mast section-4 out the TOP of mast section-3 far enough to allow access to the chain sheave wheel assembly.
9. Remove countersunk-flathead screws securing chain sheave wheel assembly attach bars on both side rails at TOP of mast section-4 and remove sheave wheel assembly.

NOTE: *When sliding mast sections apart, be careful not to scratch or score the anodized finish in the slide pad channels.*

10. Carefully slide mast section-4 out BOTTOM of section-3. Remove slide pads, shims and cable anchor plate, if necessary.

Mast Section-3 - Removal

11. Remove chain adjust nuts from threaded ends of chain attached to the chain anchor plate on BOTTOM end of mast section-3. Push threaded ends of chain through the anchor plate.
12. At TOP of mast section-3, pull chains out and allow to hang loose, *(be certain floor surface is clean and free of any metal chips or debris which may stick to lubricated chains).*
13. Slide mast section-3 out TOP of mast section-2 far enough to allow access to the chain sheave wheel assembly.
14. Remove countersunk-flathead screws securing chain sheave wheel assembly attach bars on both side rails at TOP of mast section-3 and remove the sheave wheel assembly.
15. While mast section-3 is still extended from section-2 remove the pin attaching the chain anchor plate to the TOP of mast section-3. Remove chains.

NOTE: *When sliding mast sections apart, be careful not to scratch or score the anodized finish in the slide pad channels.*

16. Carefully slide mast section-3 out BOTTOM of section-2. Remove slide pads, and shims, if necessary.

Mast Section-2 - Removal

17. Slide mast section-2 out TOP of mast section-1 far enough to allow access to the chain assembly anchor block/sheave wheel assembly.
18. Remove countersunk-flathead screws securing chain anchor block/sheave wheel assembly attach bars on both side rails at TOP of mast section-2.
19. Slide the chain anchor block/sheave wheel assembly and hydraulic cylinder out the TOP of mast section-2 far enough to allow removal of the sheave wheel attach bars, sheave wheels and sheave pin from chain assembly anchor block.
20. Remove the setscrew holding the hydraulic cylinder rod onto the chain assembly anchor block. Lay chain assembly/anchor block to side.
21. Remove the hydraulic cylinder through BOTTOM of mast section-2, be careful not to nick or score cylinder rod surface while removing.

NOTE: *When sliding mast sections apart, be careful not to scratch or score the anodized finish in the slide pad channels.*

22. Carefully slide mast section-2 out BOTTOM of section-1. Remove slide pads and shims, if necessary.

Mast Section-1 - Disassembly

23. Slide the TOP of remaining mast section-1 out over edge of work surface and remove the pins attaching the chain anchor block to mast section-1. Remove chain/anchor block assemblies from mast and lay aside.
24. Remove slide pads and shims from mast section-1.

Mast disassembly should now be complete.

SECTION 5 - MAST COMPONENTS

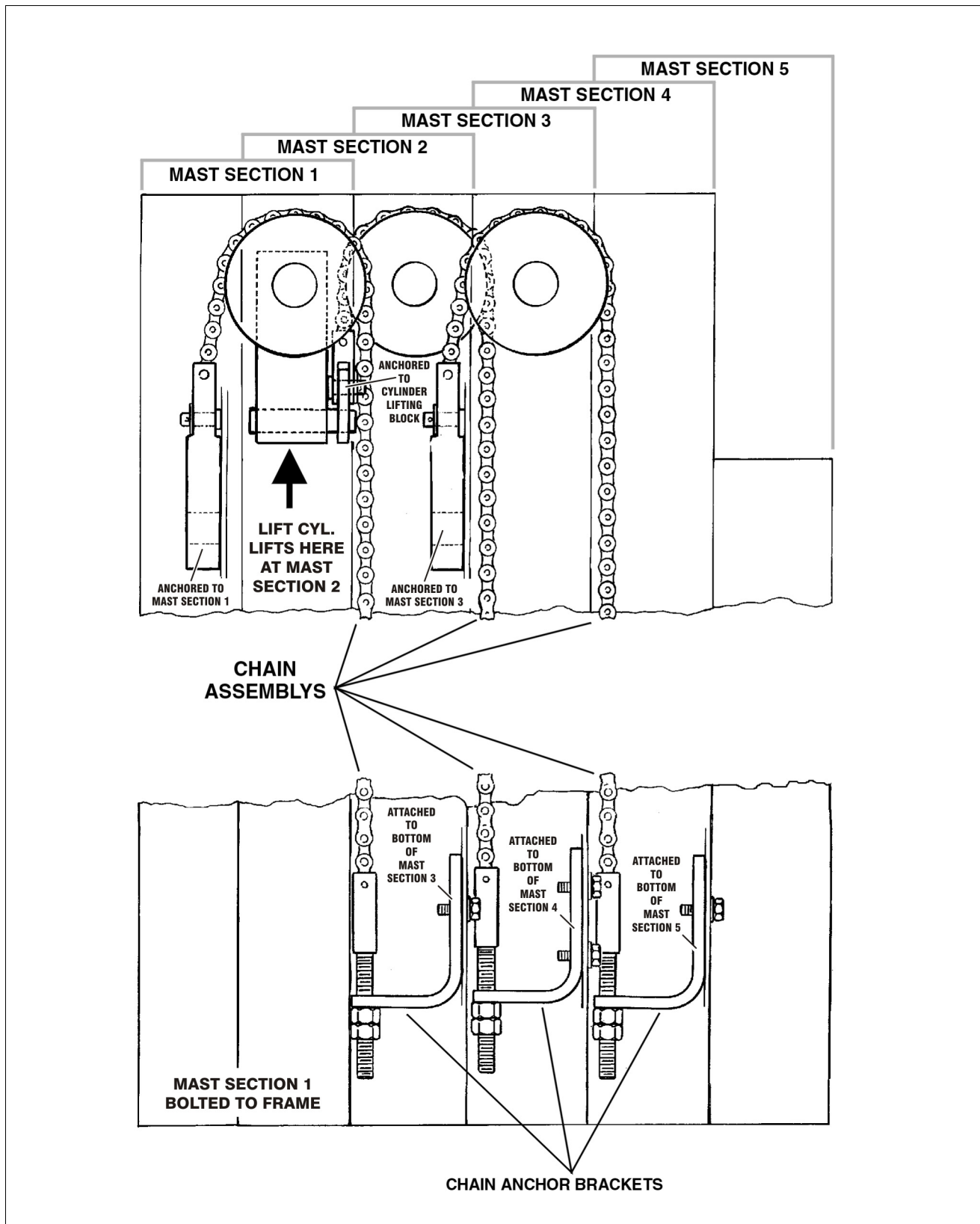
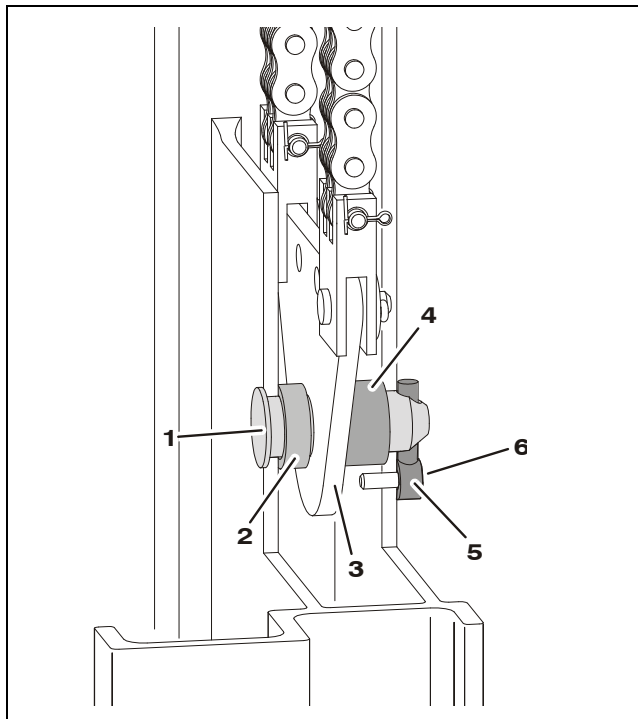

Figure 5-6. Mast Chain Routing Diagram. - MVL/MSP

Mast Assembly - MVL/MSP

Mast Section 1 - Assembly

1. Place mast section-1, rail (open) side up (See Figure 5-5. on page 5-16) on a clean, flat surface (preferably a table or work bench capable of supporting the weight of the entire mast assembly). Slide mast out over end of work surface far enough to allow access to the chain anchor attach hole near the top of the mast.
2. Locate the two (2) single (wide) chain assemblies and attach to the large equalizer anchor plate (if not already attached). Lay out the chain/anchor plate assembly with the anchor plate end towards top of the mast. (Be certain floor surface is clean and free of any metal chips or debris which may stick to lubricated chains).
3. Insert the chain/anchor plate assembly end into the top of mast section-1 and secure using the large anchor plate attach pin, spacers, and pin keeper.



**Chain/Anchor Plate Installation
(Mast Section-1 - Shown Cut-Away)**

- | | |
|-----------------------------|---------------------|
| 1. Anchor Plate Pin | 4. Long Spacer |
| 2. Short Spacer | 5. Pin Keeper |
| 3. Chain/Anchor Plate Assy. | 6. Keeper Screw (a) |

Note: (a) Apply Loctite #242 to threads.

Mast Section 2 - Assembly

NOTE: When sliding mast sections together, be careful not to scratch or score the anodized finish in the slide pad channels.

4. Locate mast section-2, carefully slide mast section-2 closed rail into section-1 open rail. Slide sections together until ends are even.
5. Insert slide pads into the slide pad channels at bottom end of mast between section-1 and -2, (one on each side of the mast), with beveled surface facing out towards section-1.

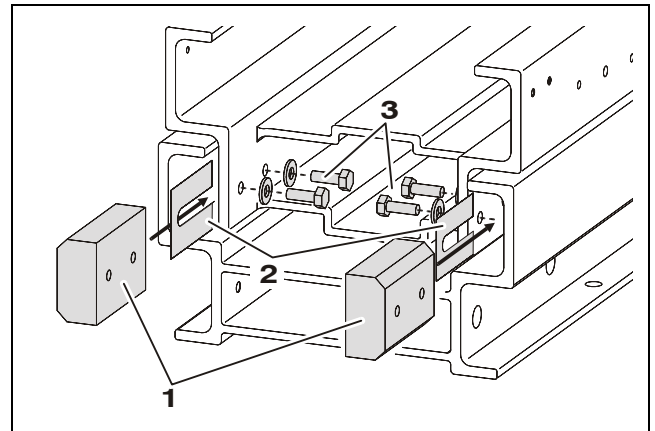

**Figure 5-7. Mast Bottom End - Slide Pad Installation
(Typical)**

1. Slide Pads 2. Shim Stock 3. Slide Pad Bolts/Washers (a)

Note: (a) Apply Loctite #242 to threads.

6. Thread slide pad attaching bolts, (two (2) 1/4"-20UNC x 3/8" long hex head bolts, place a flat washer under head of each bolt), through holes in mast section-2 inside rail, into the slide pad inserts. Thread in enough to hold pad in place.

7. Shim slide pads using the following steps:

NOTE: Always use the an even amount of shim material behind slide pads on both sides of the mast rails. This will keep mast sections centered in rail channels and prevent any distortion of the mast section.

- a. Start with a .036" thick shim and a .075" thick shim per side at each slide pad.
- b. Slide shims into place between slide pad and mast rail. Tighten the slide pad mounting bolts, be sure there are no air gaps between shims, shim and mast or shim and slide pad when tightened.

SECTION 5 - MAST COMPONENTS

c. Check mast section for side play. If play exists add .015" shims dividing the thickness equally between both sides of mast. Insert shims until the shims cannot be inserted halfway by hand with the mast pulled to the opposite side.

d. When mast slide pads are shimmed properly, there should be no side to side movement of slide pad in rail channel. Mast sections should be snug in channels but still be able to slide in channel by hand.

8. Insert slide pads into the slide pad channels (*top of mast*) between section-1 and -2, (*one on each side of the mast*), with beveled surface facing in towards section-2.

NOTE: Before fastening and shimming the slide pad on the top left side of the mast, install a sequence cable bracket against the mast under the flatwasher.

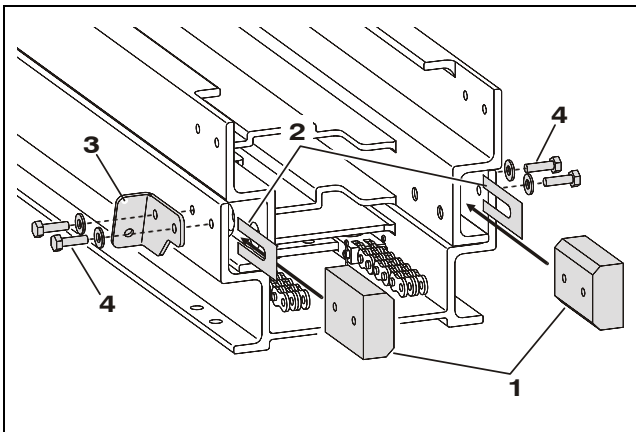

Mast Top End - Slide Pad Installation (Typical)

- | | |
|---------------|--------------------------------|
| 1. Slide Pads | 3. Sequence Cable Bracket |
| 2. Shim Stock | 4. Slide Pad Bolts/Washers (a) |

Note: (a) Apply Loctite #242 to threads.

9. Thread slide pad attaching bolts, two (2) 1/4"-20UNC x 3/8" long hex head bolts, place a flat washer under head of each bolt, through holes in mast section-1 outside rail (*top of mast*) and into the slide pad inserts. Thread in enough to hold pad in place.

10. Shim per instructions in step 7, Mast Section 2 - Assembly.

11. Lift cylinder installation into the bottom of Mast Section 1 and 2.

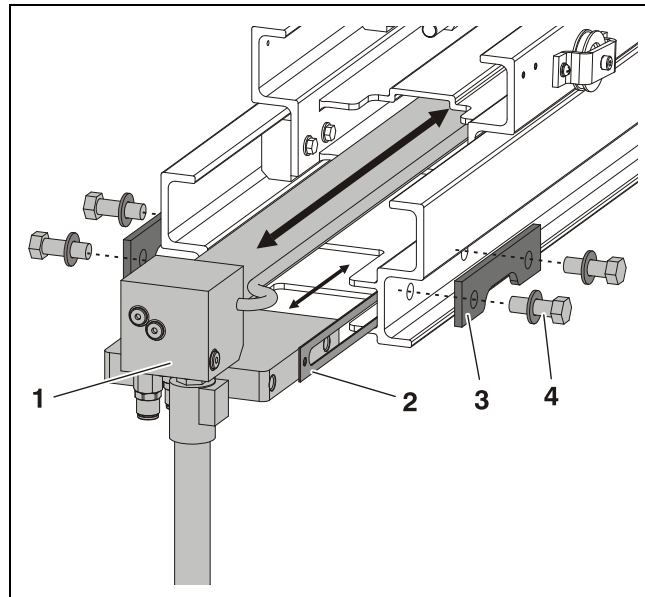

Lift Cylinder Mount Installation

- | | |
|-------------------|-----------------------------|
| 1. Cylinder Mount | 3. Mast Reinforcement Plate |
| 2. Shim Stock | 4. Mount Screws/Washers (a) |

Note: (a) Apply Loctite #242 to threads.

NOTE: The cylinder rod needs to be extended out of the cylinder approximately 12 in. (30cm) before installation for later attachment of the upper chain anchor block to mast section-2. Remove any protective caps on the extend and return ports temporarily to allow rod extension. Catch any oil draining out of cylinder to avoid spillage onto work area. Be careful not to nick or scour rod surface when extending and during installation.

12. Slide the lift cylinder into the closed rail side of mast section-2 and the cylinder mount into mast section-1 closed rail, with the manual descent valve pointing down towards the back of the mast assembly.

13. Check the mount side to side clearance. Use mounting shims of equal thickness on each side to center the mount in the closed rail of section-1, if necessary.

14. Install the cylinder mounting reinforcement plates 1 each side and secure the cylinder assembly to the mast using the cylinder mounting screws and washers. Apply Loctite #242 to the screw threads before final tightening.

15. Slide mast section-2 out of mast section-1 approximately 8 in. (20cm).
16. Assemble one of the narrow chains sets (#444) and to the small chain equalizer anchor plate using the pins, washers and cotter keys. Set aside.
17. Locate the chain anchor block and slide it onto the hydraulic cylinder rod end extending out the top of mast section 2.
18. Lay out the chain(#444)/anchor plate assembly with anchor plate end towards mast, *(be certain floor surface is clean and free of any metal chip or debris which may stick to lubricated chains or lay chains in a clean bucket).*
19. Assemble the chain/anchor plate assembly and the chain anchor block to the cylinder rod end using the anchor plate/block attach pin and snap ring.

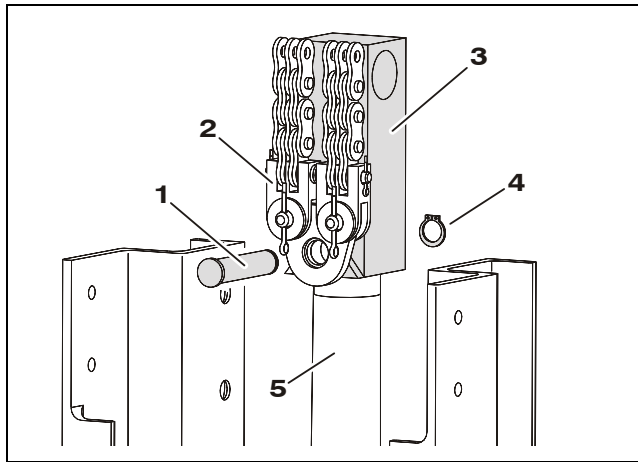

Install Chain/Anchor Block to Top of Lift Cylinder

- | | |
|-----------------------------|----------------------------|
| 1. Attach Pin | 4. Attach Pin - Snap Ring |
| 2. Chain/Equalizer Assembly | 5. Cylinder Rod (Extended) |
| 3. Chain/Anchor Block | |

20. Assemble chain sheaves on chain assembly anchor block *(attached to cylinder rod end)* and attach to mast section-2 using following steps;
 - a. Insert sheave pin through anchor block and cylinder rod on cylinder rod end.
 - b. Load three 1" flat washers onto the sheave pin on each side of the anchor block.
 - c. Place sheave wheels *(for wide #544 chain)* on sheave pin, one each side of anchor block.
 - d. On the outside of each sheave wheel, place another 1" flatwasher, a roll pin *(into the slot in each end of the pin)*, and then place a sheave pin support bar *(rectangular plate with threaded holes on each side of pin bore hole)*.

- e. Slide the whole anchor block/cylinder assembly with sheave pin, wheels and pin support bars into top of mast section-2.
- f. Align the threaded holes in the attach bars on each side of the mast and attach to top of mast section-2 using two (2) 3/8"-16UNC x 1/2" long socket head-countersunk-flathead cap screws each side. Coat threads with Loctite #171 and tighten.

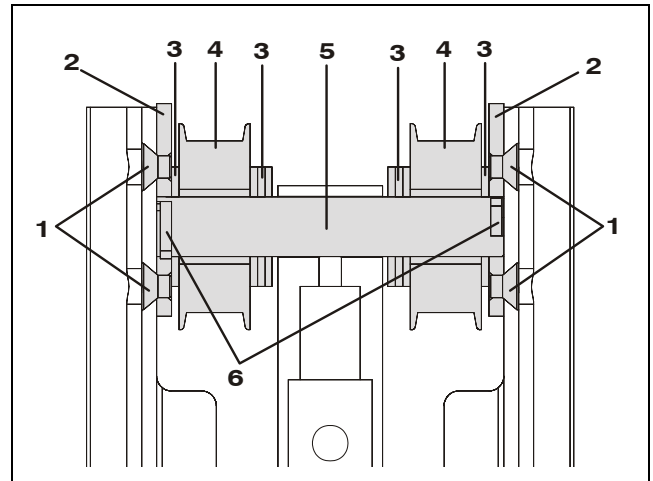

Mast Section 2 - Chain/Anchor Block (Sheave Wheel Assembly)

- | | |
|--------------------------|-----------------------|
| 1. Support Bar Screws(a) | 4. Sheave Wheel Assy. |
| 2. Pin Support Bars | 5. Sheave Pin |
| 3. Narrow Washers | 6. Square Keys |

Note: (a) Apply Loctite #242 to threads.

21. Remove the cylinder mount cap - shoulder screws and apply Loctite #242 to the threads. Install the screws and torque to 85 ft. lbs.
22. Tighten the center lift cylinder mount screw, this screw keeps the cylinder assembly from rotating in the mount.
23. Slide mast section-2 back into section-1 until top and bottom ends are even.

SECTION 5 - MAST COMPONENTS

Mast Section 3 - Assembly

NOTE: When sliding mast sections together, be careful not to scratch or score the anodized finish in the slide pad channels.

24. Carefully slide mast section-3 into section-2 until ends are even.
25. Insert slide pads into the top end mast rails between section-2 and -3, (one on each side of the mast), with beveled surface facing inward towards section-3.

NOTE: Before fastening and shimming the slide pad on the top left side of the mast, install a sequence cable bracket against the mast under the flatwasher.

26. Thread slide pad attaching bolts, two (2) 1/4"-20UNC x 3/8" long hex head bolts, place a flat washer under head of each bolt, through holes in outside rail, on top of mast section-2 and into the slide pad inserts. Thread in enough to hold pad in place.
27. Shim per instructions in step 7, Mast Section 2 - Assembly.
28. Insert slide pads into the bottom end mast rails between section-2 and -3, (one on each side of the mast), with beveled surface facing out towards section-2. (Same as Figure 5-7. on page 5-19)
29. Thread slide pad attaching bolts, two (2) 1/4"-20UNC x 3/8" long hex head bolts, place a flat washer under head of each bolt, through holes on inside rail, on bottom end of mast section-3 and into the slide pad inserts. Thread in enough to hold pad in place.
30. Shim per instructions in step 7, Mast Section 2 - Assembly.
31. Slide section-3 out the bottom of section-2 approximately one (1) foot.
32. Locate one (1) of the chain (bottom) anchor brackets (one with threaded holes horizontally aligned to outside of bracket). Attach using outer set of holes in bottom of mast section-3 with two (2) 1/4"-20UNC x 3/4" long bolts, place a flatwasher under head of each bolt.
33. Slide section-3 out the top of section-2 approximately one (1) foot.

34. Locate the remaining narrow chain set (#444) and attach them to the remaining triangular shaped anchor plate using the attach pins, flat washers and cotter keys.
35. Install the chain/anchor plate assembly into the top of mast section-3, using the remaining large pin and

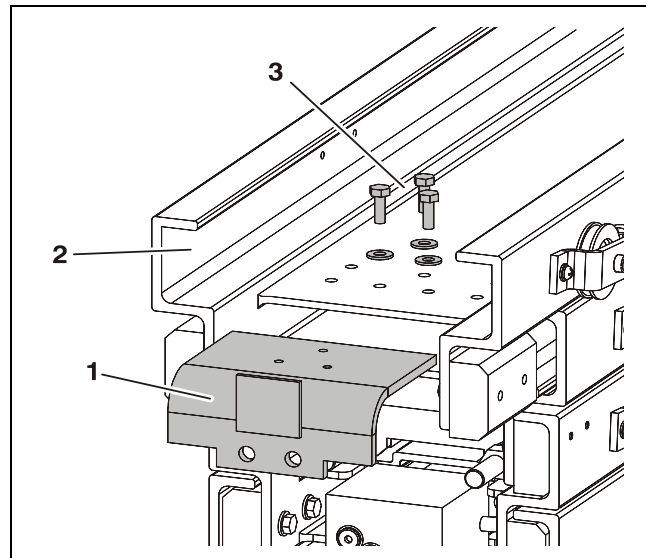

**Mast Section 3 - Chain Anchor Bracket
(Bottom of Mast)**

- | | |
|-------------------------|-----------------------------|
| 1. Chain Anchor Bracket | 3. Anchor Bolts/Washers (a) |
| 2. Mast Section 3 | |

Note: (a) Apply Loctite #242 to threads.

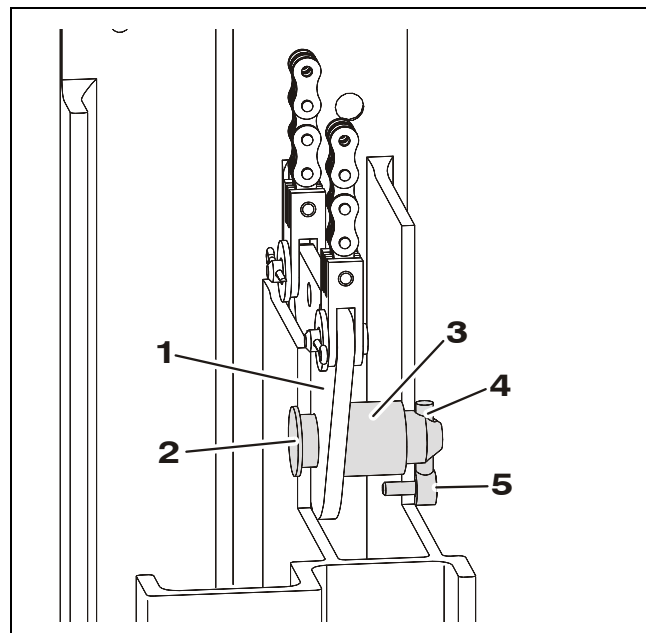

**Mast Section 3 - Chain/Anchor Plate Installation
(Mast Section-3 Shown Cut-away)**

- | | |
|-----------------------------|---------------------|
| 1. Chain/Anchor Plate Assy. | 4. Pin Keeper |
| 2. Anchor Pin | 5. Keeper Screw (a) |
| 3. Spacer | |

Note: (a) Apply Loctite #242 to threads.

pin keeper. Allow to hang out the top of mast section-3 for later assembly.

36. Insert the threaded the ends of chain assembly (*attached to top of mast section-1*), into the opening between mast section-2 and mast section-3. Slide the threaded ends through the holes in chain anchor bracket attached at the bottom of mast section-3. Loosely thread two (2) 3/8"-16UNC nuts onto stud threads on each chain and remove any slack in the chains. Chains will be adjusted later in assembly.
37. Assemble chain sheaves (*for narrow chain assembly*) to top of mast section-3 as follows;
 - a. Place four (4) of the 1" flat washers onto one of the remaining sheave pins. Locate two (2) narrow chain sheave wheels and slide onto sheave pin on each side of the flat washers.
 - b. Slide two (2) short spacer tubes onto sheave pin, one each end of sheave pin to outside of sheave wheels.
 - c. Place two (2) sheave pin support bars, one each end of sheave pin onto outside of spacer tubes. Place a roll pin in the slots at each end of the sheave pins and align with the cutouts in the pin support bars.
 - d. Holding complete sheave wheel assembly, slide assembly into top of mast section-3 and align threaded holes in sheave pin support bars with holes in mast rails.
 - e. Attach to top of mast section-3 using two (2) 3/8"-16UNC x 1/2" long socket head-countersunk-flathead cap screws, each side. Coat threads with Loctite #171 and tighten.

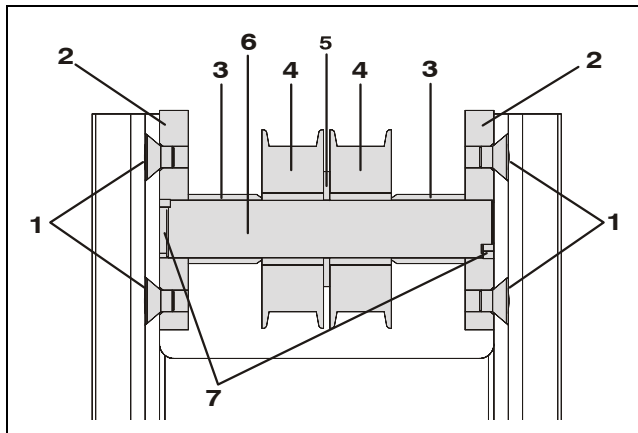

Mast Section 3 - Sheave Wheel Assembly

- | | |
|---------------------------|------------------|
| 1. Support Bar Screws (a) | 5. Narrow Washer |
| 2. Pin Support Bars | 6. Sheave Pin |
| 3. Wide Spacers | 7. Square Keys |
| 4. Sheave Wheel Assys. | |

Note: (a) Apply Loctite #242 to threads.

38. Slide mast section-3 back into section-2 until ends are even. Check to make sure chain assembly (*wide chains*) are seating properly in chain anchor block chain sheave wheels attached to mast section-2.

Mast Section 4 - Assembly

NOTE: When sliding mast sections together, be careful not to scratch or score the anodized finish in the slide pad channels.

1. Carefully slide mast section-4 into section-3 until ends are even.
2. Insert slide pads into the top end mast rails between section-2 and -3, (*one on each side of the mast*), with beveled surface facing inward towards section-3.

NOTE: Before fastening and shimming the slide pad on the top left side of the mast, install a sequence cable bracket against the mast under the flatwasher.

3. Thread slide pad attaching bolts, two (2) 1/4"-20UNC x 3/8" long hex head bolts, place a flat washer under head of each bolt, through holes in outside rail, on top of mast section-2 and into the slide pad inserts. Thread in enough to hold pad in place.
4. Shim per instructions in step 7, Mast Section 2 - Assembly.
5. Insert slide pads into the bottom end mast rails between section-2 and -3, (*one on each side of the mast*), with beveled surface facing out towards section-2. (*Same as Figure 5-7. on page 5-19*)
6. Thread slide pad attaching bolts, two (2) 1/4"-20UNC x 3/8" long hex head bolts, place a flat washer under head of each bolt, through holes on inside rail, on bottom end of mast section-3 and into the slide pad inserts. Thread in enough to hold pad in place.
7. Shim per instructions in step 7, Mast Section 2 - Assembly.
8. Slide section-4 out the bottom of section-3 approximately one (1) foot.
9. Locate one (1) of the chain bottom anchor plates (*one with threaded holes horizontally aligned to center of bracket*). Attach using holes in bottom of mast section-4 with four (4) 1/4"-20UNC x 3/4" long bolts, place a flatwasher under head of each bolt.

SECTION 5 - MAST COMPONENTS

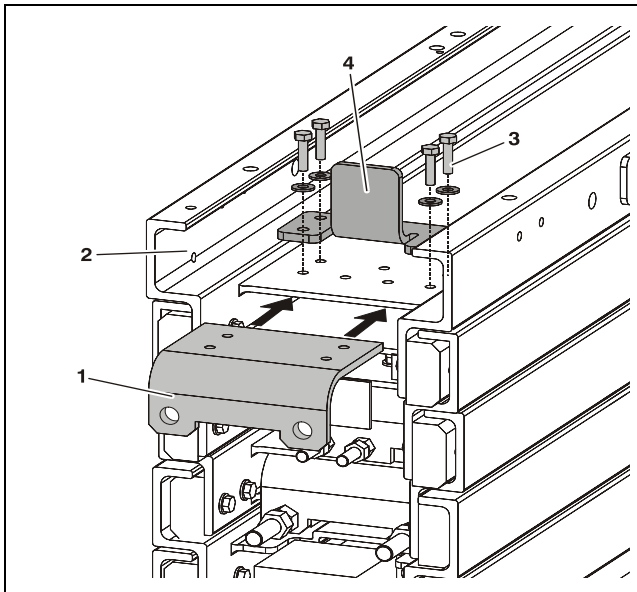

**Mast Section 4 - Chain Anchor Bracket
(Bottom of Mast)**

- | | |
|-------------------------|------------------------------|
| 1. Chain Anchor Bracket | 3. Anchor Bolts/Washers (a) |
| 2. Mast Section 4 | 4. Pot-Hole Actuator Bracket |

Note: (a) Apply Loctite #242 to threads.

10. Slide section-4 out the top of section-3 approximately one (1) foot.
11. Insert threaded ends of chain assembly (*attached to top of mast section-2*), into the opening between mast section-3 and mast section-4. Slide the threaded ends through the holes in bottom anchor plate attached to bottom of mast section-4. Loosely thread two (2) 3/8"-16UNC nuts onto stud threads on each chain until all slack is taken out of chain. Chains will be adjusted later in assembly.
12. Assemble chain sheaves (*for narrow chain assembly*) to top of mast section-4 as follows;
 - a. Locate the remaining sheave pin and slide the wide tube spacer onto the pin shaft.
 - b. Place two (2) of the narrow chain sheave wheels onto the sheave pin on each side of the wide spacer.
 - c. Slide two (2) 1" flat washers onto each end of sheave pin to outside of sheave wheels.
 - d. Place two (2) sheave pin support bars, one each end of sheave pin to outside of space tubes. Place a roll pin in the slots at each end of the sheave pins and align with the cutouts in the pin support bars.
 - e. Holding complete sheave wheel assembly, slide assembly into top of mast section-4 and align

threaded holes in sheave pin support bars with holes in mast rails.

- f. Attach to top of mast section-4 using two (2) 3/8"-16UNC x 1/2" long socket head-countersunk-flathead cap screws, each side. Coat threads with Loctite #171 and tighten.

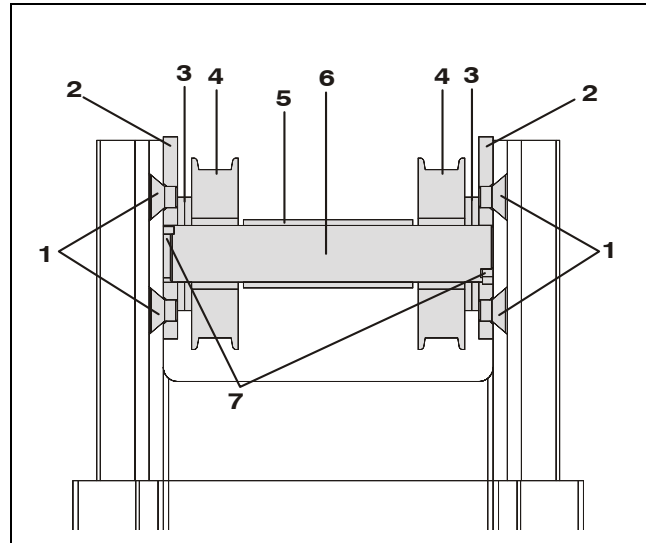

Mast Section 4 - Sheave Wheel Assembly

- | | |
|---------------------------|----------------|
| 1. Support Bar Screws (a) | 5. Wide Spacer |
| 2. Pin Support Bars | 6. Sheave Pin |
| 3. Narrow Washers | 7. Square Keys |
| 4. Sheave Wheel Assys. | |

Note: (a) Apply Loctite #242 to threads.

13. Carefully slide mast section-4 into section-3 until ends are even. Check to make sure chain assembly (*narrow chains*) are seating properly in chain anchor block chain sheave wheels attached to mast section-3.

Mast Section 5 - Assembly

1. Locate the remaining mast section-5 (*platform mounting - mast section*). Lay mast section on a flat stable surface.
2. Attach the remaining chain bottom anchor plate (*one with threaded holes aligned at the outside of bracket*). Attach through set of holes in bottom of mast section-5 with four (4) 1/4"-20UNC x 3/4" long bolts, place a flatwasher under head of each bolt.

NOTE: The platform mounting section slide pads, are assembled differently than the slide pads for the other mast sections. Mast section-5 slide pads may need to be assembled/disassembled several times in order to determine the correct shim stock required for proper fit.

3. Complete the following steps to determine shim stock thickness required for section-5;

NOTE: Always use the an even amount of shim material behind slide pads on both sides of the mast rails. This will keep mast sections centered in rail channels and prevent any distortion of the section.

- a. Use two shim pieces per slide pad, a thick one and a thin one.
- b. Start with a total thickness of approximately .035" and .075" thick shim stock.
- c. Attach shim stock and slide pads to both sides of mast section-5 using five (5) 1/4"-20UNC x 1-1/4" long, hex head cap screws per side, with flatwasher under each bolt head. (Assemble shim stock and slide pad to mast section rail with shim stock against rail and slide pad with beveled side out).
- d. Carefully thread the slide pad mounting bolts with flat washers through slide pads and shim stock into threads in mast section-5. Be certain there are no air gaps between shims, shim and mast or shim and slide pad when tightened.

NOTE: Mast section-5 into section-4 fit should be very snug but still be able to be pushed together by hand. If too

tight, remove section-5, disassemble slide pad and reduce thickness of shim stock.

- e. Begin sliding top of mast section-5 with closed rail down engaging the slide pads into slide pad channels at bottom of mast section-4's open rail. Continue to push section-5 into section-4 until BOTTOM ends of mast sections are even.
 - f. Check mast section for side play. If play exists use thicker shims dividing thickness equally between both sides of mast.
 - g. When mast slide pads are shimmed properly, there should be no side to side movement of slide pad in rail channel. Mast sections should be very snug in channels but still be able to slide in channel by hand.
4. Slide mast section-5 out even with top of section-4.
 5. Insert threaded ends of chain assembly (attached to top of mast section-3) into the opening between mast section-4 and mast section-5. Slide the threaded ends through the holes in bottom chain anchor plate located on bottom of mast section-5. Loosely thread two (2) 3/8"-16UNC nuts onto stud threads on each chain. Chains will be adjusted later in assembly.

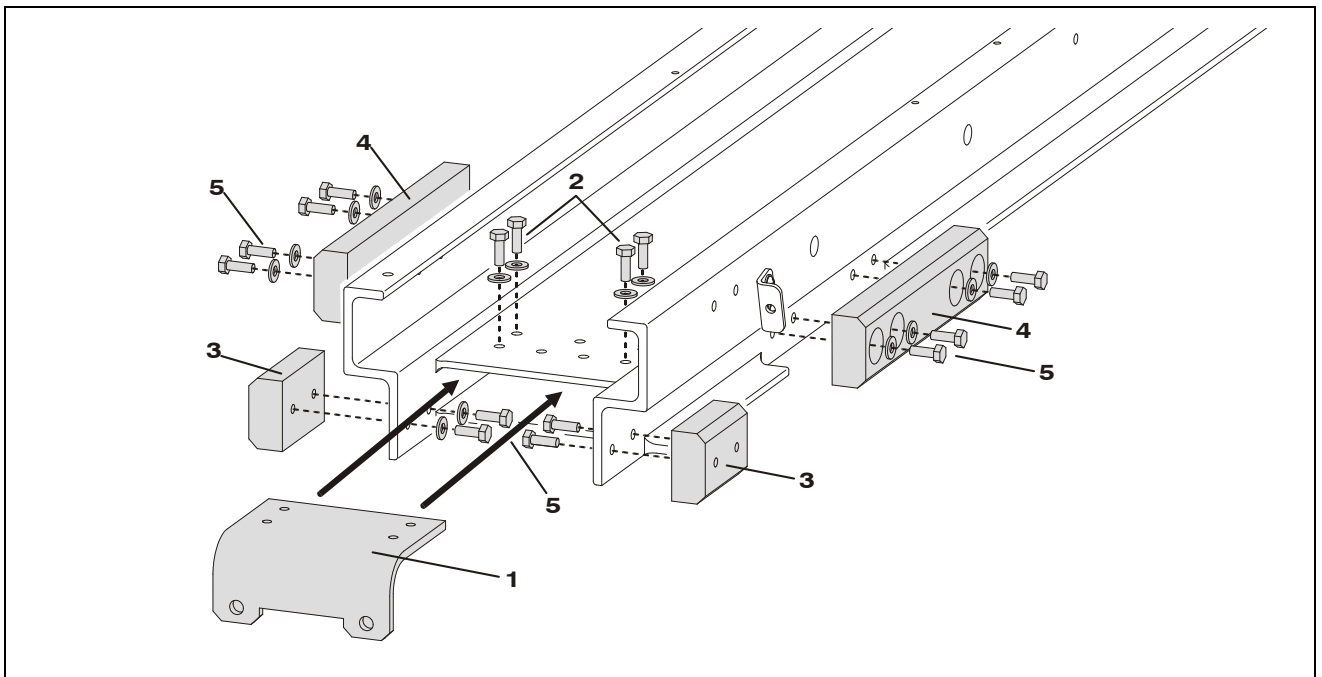

**Mast Section 5 - Bottom End Components
(Chain Anchor Bracket and Slide Pad Installation)**

- | | | |
|------------------------------------|-------------------|--------------------------------|
| 1. Chain Anchor Bracket | 3. Slide Pad | 5. Slide Pad Bolts/Washers (a) |
| 2. Anchor Bracket Bolts/Washers(a) | 4. Long Slide Pad | |

Note: (a) Apply Loctite #242 to threads.

SECTION 5 - MAST COMPONENTS

6. Slide mast section-5 back into mast section-4 until bottom ends of masts are even. Check to make sure chain set attached to top of section-3 is seating properly in cable sheave wheels attached to top of mast section-4. *(Mast section-3 may need to be restrained to keep it's slide pads from pushing out the bottom of mast sections-2).*
7. At bottom of mast assembly, thread all chain adjusting nuts on threaded ends until they are snug against the bottom anchor plates and all slack is removed from chains. Check that chains are seated in their sheave wheels at top of mast assembly.
8. Do not assemble the mini covers to the top of mast sections until the mast chains have been adjusted properly.
9. Attach the lanyard attach assembly to the side of mast section 5.
10. Attach the sequencing cables and hardware to the sides of the mast assembly.
11. Install the mast chain guard to the top mast section 5.

The mast assembly is now ready to install on the machines base frame.

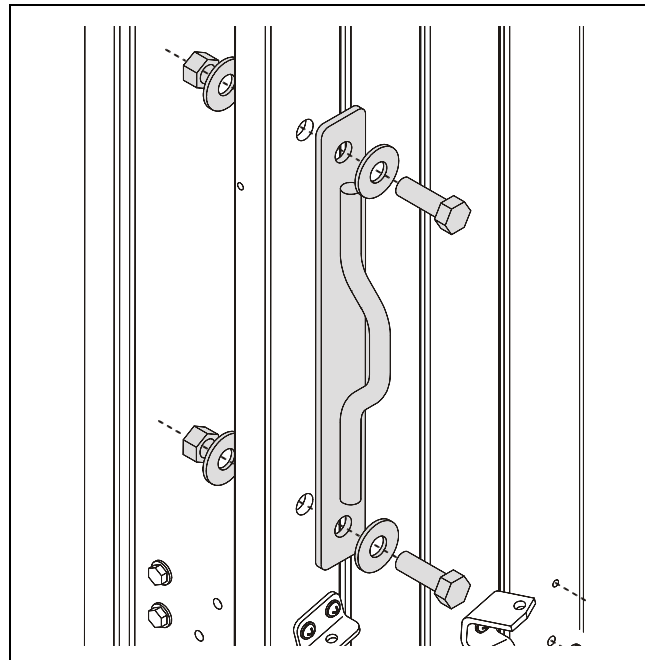

Lanyard Attach Installation

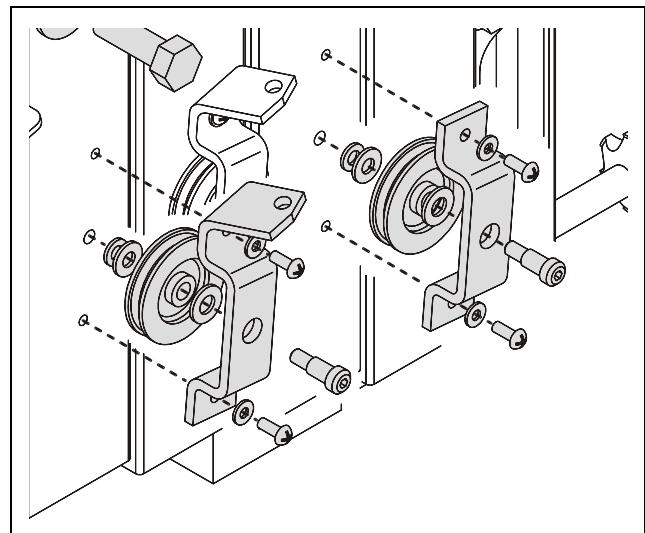

**Sequence Cable Bracket Installation)
(Bottom End)**

5.8 MSP - STOCKPICKER PLATFORM - INSTALLATION

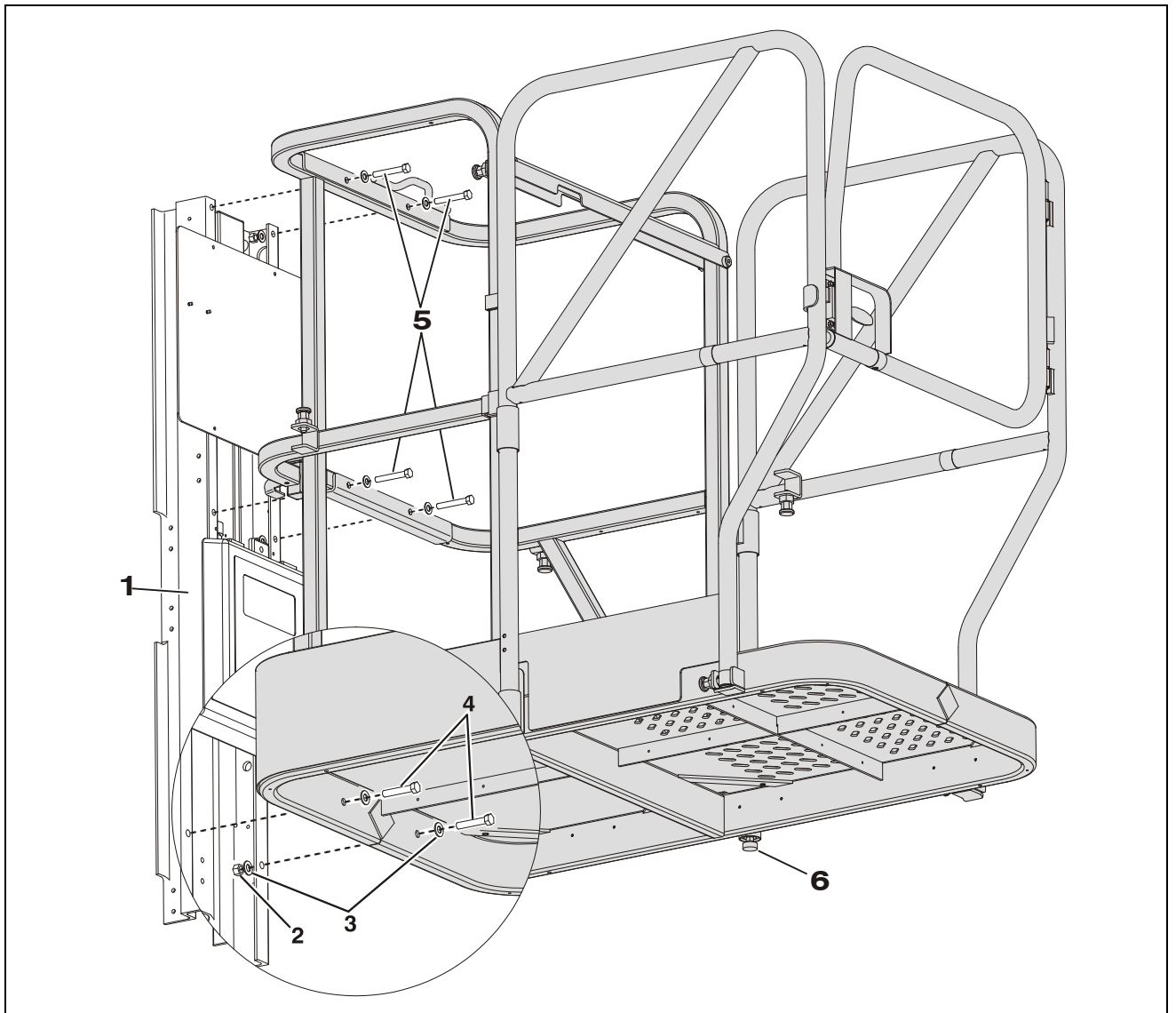
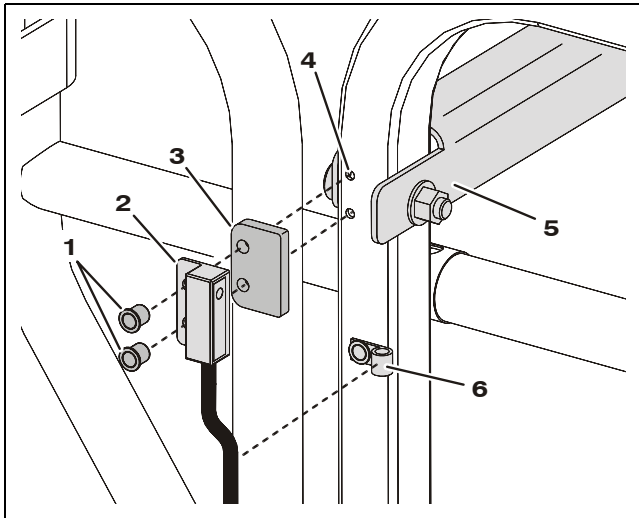

Figure 5-8. MSP - StockPicker Platform Installation.

- | | | |
|---------------------------------|-----------------------------|---------------------------------|
| 1. Mast Platform Header Section | 3. Washers | 5. Hex Head Screws (2-1/2 inch) |
| 2. Nut | 4. Hex Head Screws (2 inch) | 6. Platform Bumper Rest (a) |

Note: (a) Once mounted, adjust bumper rests on both sides evenly so the platform rests on the bumpers when in stowed position.

5.9 MSP - STOCKPICKER PLATFORM - MID-GATE INTERLOCK INSTALLATION



MSP - Platform - Mid-Gate Interlock Switch Installation

- | | |
|---------------------|-----------------------|
| 1. Pop Rivets | 4. Mounting Holes |
| 2. Interlock Switch | 5. Mid-Gate |
| 3. Spacer | 6. Wire Harness Clamp |

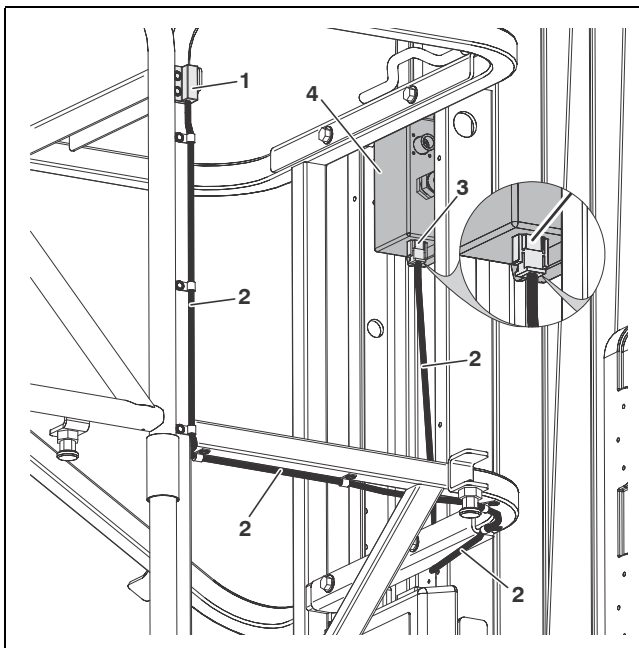

MSP - Platform - Mid-Gate Interlock Switch Wiring Harness Routing

- | | |
|---------------------|-------------------------------|
| 1. Interlock Switch | 3. Connection at Junction Box |
| 2. Wire Routing | 4. Platform Junction Box |

Note: Decal billboard removed in above illustration.

5.10 MAST BEACON - INSTALLATION

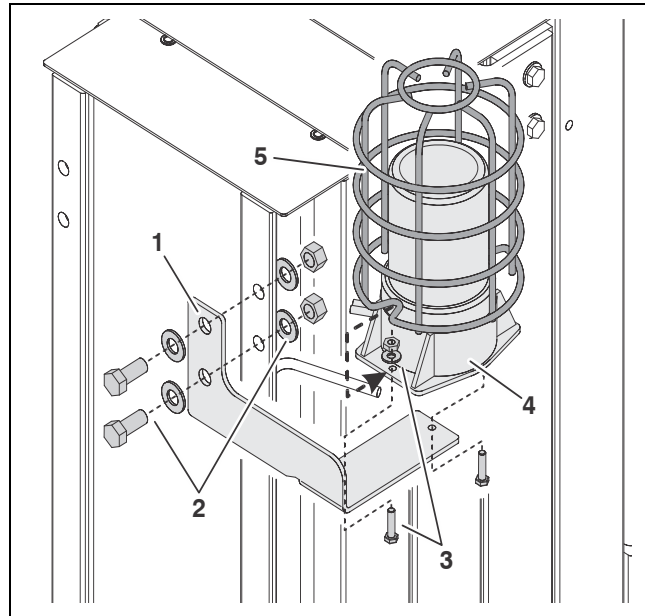

Mast Mounted Beacon Installation (MVL/MSP)

- | | |
|--------------------------------|---------------------|
| 1. Beacon Mounting Bracket | 4. Beacon Assembly |
| 2. Bracket Screws/Nuts/Washers | 5. Beacon Guard (a) |
| 3. Beacon Screws/Nuts/Washers | |

Note: (a) Guard on UL-EE specification machines only.

5.11 GATE ALARM - INSTALLATION - OPTION (FOR SIDE ENTRY W/FOLDING MATERIAL TRAY PLATFORM ONLY)

NOTE: Machine must have v6.11 or higher software in the Ground Control Module.

Ground Control Module Programming settings required:

- Set Ancillary 1 POL to HIGH (Up Arrow)
- Set AUX 1 INHIBIT to 5

Switches and Wiring

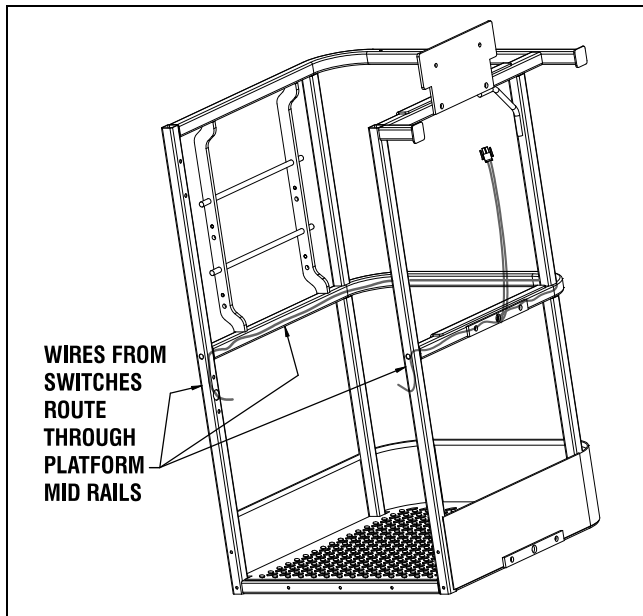

Proximity Switch Wire Harness Routing

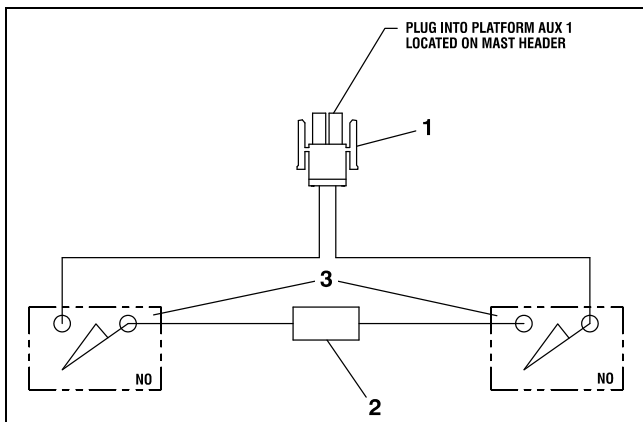

Proximity Switch Wiring

- 1. Connector
- 2. Splice
- 3. Proximity Switches

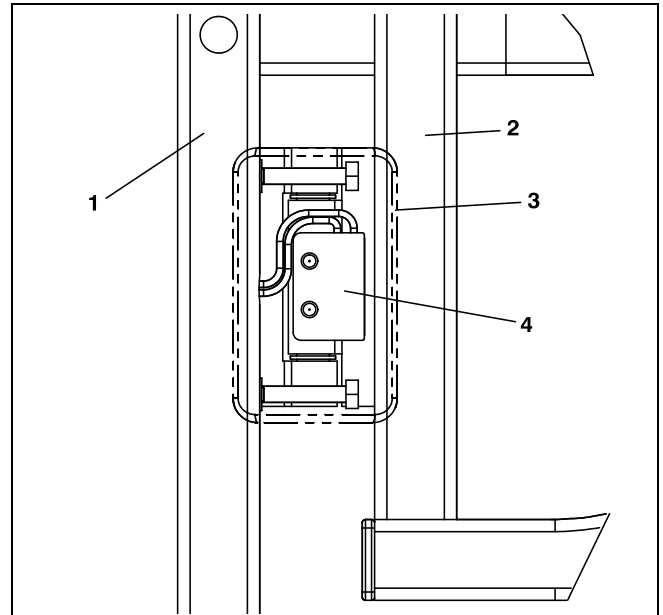

Proximity Switch Location

- 1. Platform Vertical Rail
- 2. Left Platform Gate
- 3. Lower Gate Stop
- 4. Proximity Switch (a)

NOTE: (a) There are two proximity switches, one on each gate mounted in the lower gate stop.

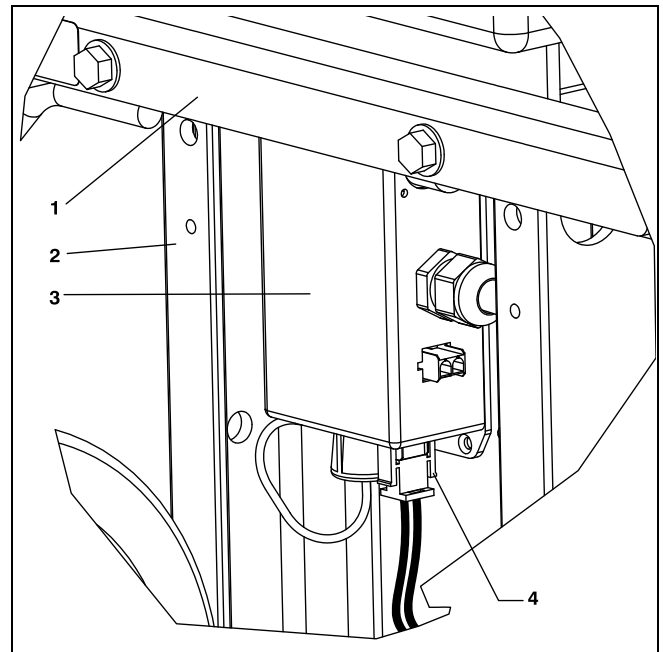

Platform Junction Box

- 1. Platform Upper Rail
- 2. Mast Header
- 3. Platform Junction Box
- 4. AUX 1 Connector

5.12 MAST - 14 FT. HEIGHT LIMITING SWITCH -15MSP (OPTION)

Ground Control Module Programming settings required:

- Set Ancillary 2 POL to HIGH (Up Arrow)

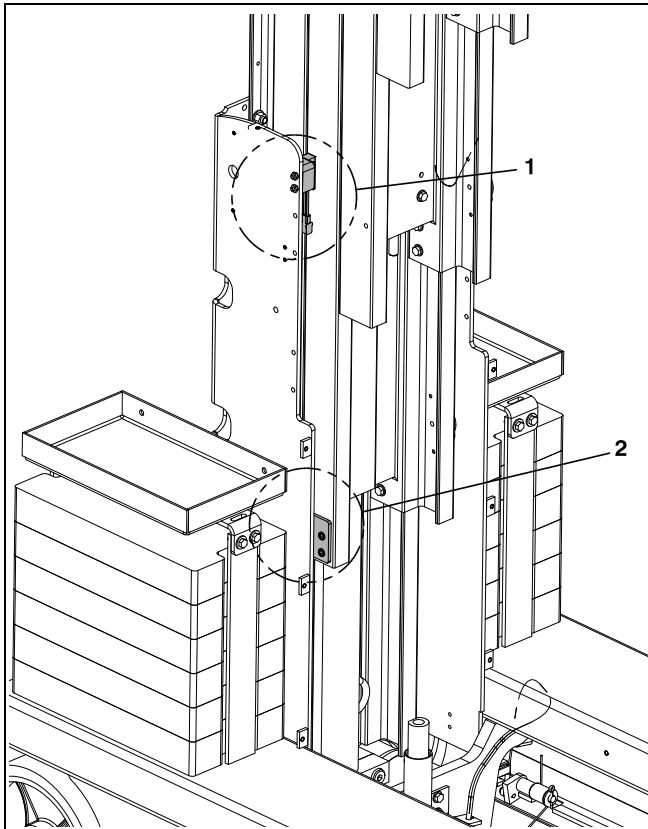

Location of Proximity Switch and Target
(Right side of mast from rear)

- 1. Proximity Switch
- 2. Target Plate

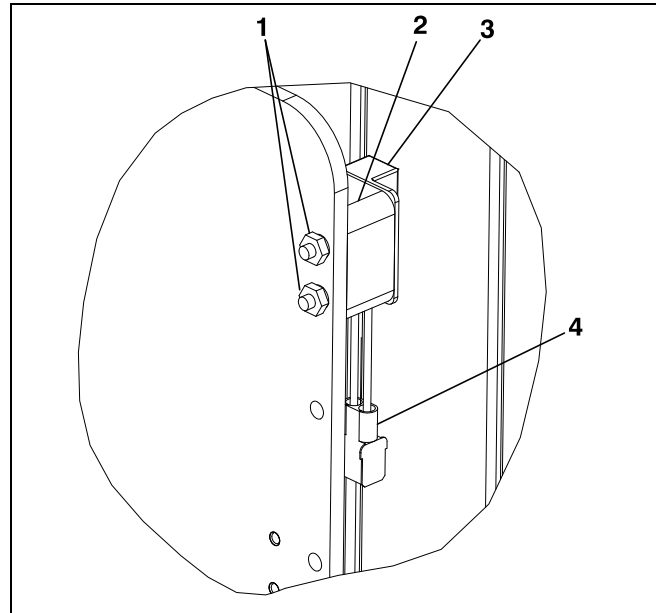

Proximity Switch Installation

- 1. Mounting Screws, Nuts and Washers
- 2. Switch Shim
- 3. Proximity Switch
- 4. Harness Connector (a)

NOTE: (a) Proximity switch wiring is routed through hole in the mast connect support to main harness "Aux 2 Input" connector (orange/red 49-6, black 13), located under center rear cover on the left side of the pump/motor.

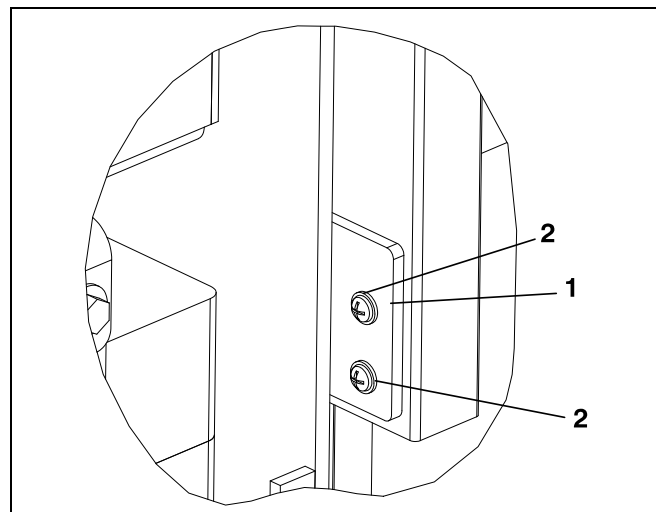

Target Plate Installation

- 1. Target Plate
- 2. Mounting Screws and Washers (a)

NOTE: (a) Secure to mast using existing holes.

SECTION 6. TROUBLESHOOTING

6.1 GENERAL

This section contains troubleshooting information to be used for locating and correcting most operating problems. If a problem should develop which is not presented in this section or which is not corrected by listed corrective actions, technically qualified guidance should be obtained before proceeding with any maintenance.

NOTICE

IT IS A GOOD PRACTICE TO AVOID PRESSURE-WASHING ELECTRICAL/ELECTRONIC COMPONENTS. SHOULD PRESSURE-WASHING BE UTILIZED TO WASH AREAS CONTAINING ELECTRICAL/ELECTRONIC COMPONENTS, JLG INDUSTRIES, INC. RECOMMENDS A MAXIMUM PRESSURE OF 750 PSI (52 BAR) AT A MINIMUM DISTANCE OF 12 INCHES (30.5 CM) AWAY FROM THESE COMPONENTS. IF ELECTRICAL/ELECTRONIC COMPONENTS ARE SPRAYED, SPRAYING MUST NOT BE DIRECT AND BE FOR BRIEF TIME PERIODS TO AVOID HEAVY SATURATION.

6.2 TROUBLESHOOTING INFORMATION

Troubleshooting procedures applicable to this machine are listed and defined starting with Section 6.8, TROUBLESHOOTING TABLES Index in this section of the manual.

Each malfunction within an individual group or system is followed by a listing of probable causes which will enable determination of the applicable remedial action. The probable causes and the remedial action should, where possible, be checked in the order listed in the troubleshooting tables.

It should be noted that there is no substitute for a thorough knowledge of the equipment and related systems.

It should be recognized that the majority of the problems arising in the machine will be centered in the hydraulic and electrical systems. For this reason, every effort has been made to ensure that all likely problems in these areas are given the fullest possible treatment. In the remaining machine groups, only those problems which are symptomatic of greater problems which have more than one probable cause and remedy are included. This means that problems for which the probable cause and remedy may be immediately obvious are not listed in this section.

The first rule for troubleshooting any circuit that is hydraulically operated and electrically controlled is to determine if the circuit is lacking hydraulic oil and electrical control power. This can be ascertained by overriding the bypass valve (*mechanically or electrically*) so that oil is available to the function valve, then overriding the function valve mechanically. If the function performs satisfactorily, the problem exists with the control circuit.

6.3 HYDRAULIC CIRCUIT CHECKS (SEE FIGURE 6-8.)

The first reference for improper function of a hydraulic system, where the cause is not immediately apparent, should be the Hydraulic Diagram Circuit. The best place to begin the problem analysis is at the power source (*pump*). Once it is determined that the pump is serviceable, then a systematic check of the circuit components, would follow.

NOTE: For aid in troubleshooting, refer to Figure 6-8. for HYDRAULIC DIAGRAM circuit.

6.4 ELECTRICAL CIRCUIT CHECKS

General

The drive system on the MVL and MSP machines requires a microprocessor controlled electrical circuit to operate smoothly and accurately. All platform control console functions are relayed to various machine components (*i.e. platform up/down, drive functions, etc.*) through the Ground Control Module microprocessor box (*mounted at the rear of the machine*). The Ground Control Module is pre-programmed with factory pre-set personality settings for each machine function.

To help diagnose any problems with components plugged into the Ground Control Module, the module is designed with an internal fault code and text messaging system displayed on an LCD screen at the module. The platform control console also will display LED Flash Codes using the LED strip at the top of the console. When operating normally the LED panel on the platform control console indicates the battery voltage status using ten (10) LEDs (*red/yellow/green*). If a malfunction to the

SECTION 6 - TROUBLESHOOTING

machine's electrical components occurs, the platform console LED's will flash a number of LEDs to help indicate the problem to the Operator in the platform. The Fault Codes and LED Flash Codes are outlined in the following sub-sections of this chapter.

NOTE: For aid in troubleshooting electrical problem, refer to Figure 6-7. for an *ELECTRICAL DIAGRAM* of the various circuits. Also for a pictorial overview of the connected components, See Figure 6-6. "Pictorial Overview of the MVL/MSP Electrical System".

6.5 MULTIMETER BASICS

A wide variety of multi-meters or Volt Ohm Meters (VOM) can be used for troubleshooting your equipment. A digital meter with reasonable accuracy (within 7%) is recommended for the measurements in these procedures. This section shows diagrams of a common, digital VOM configured for several different circuit measurements. Instructions for your VOM may vary. Please consult the meter operator's manual for more information.

Grounding

"Grounding the meter" means to take the black lead (which is connected to the COM (common) or negative port) and touch it to a good path to the negative side of the voltage source.

Back-Probing

To "back-probe" means to take the measurement by accessing a connector's contact on the same side as the wires, the back of the connector. Readings can be done while maintaining circuit continuity this way. If the connector is the sealed type, great care must be taken to avoid damaging the seal around the wire. It is best to use probes or probe tips specifically designed for this technique, especially on sealed connectors. Whenever possible insert probes into the side of the connector such that the test also checks both terminals of the connection. It is possible to inspect a connection within a closed connector by back-probing both sides of a connector terminal and measuring resistance. Do this after giving each wire a gentle pull to ensure the wires are still attached to the contact and contacts are seated in the connector.

Min/Max

Use of the "Min/Max" recording feature of some meters can help when taking measurements of intermittent conditions while alone. For example, you can read the voltage applied to a solenoid when it is only operational while a switch, far from the solenoid and meter, is held down.

Polarity

Finding a negative voltage or current reading when expecting a positive reading frequently means the leads are reversed. Check what reading is expected, the location of the signal and that the leads are connected to the device under test correctly. Also check that the lead on the "COM" port goes to the ground or negative side of the signal and the lead on the other port goes to the positive side of the signal.

Scale

M = Mega = 1,000,000 * (Displayed Number)

k = kilo = 1,000 * (Displayed Number)

m = milli = (Displayed Number) / 1,000

μ = micro = (Displayed Number) / 1,000,000

Example: 1.2 k Ω = 1200 Ω

Example: 50 mA = 0.05 A

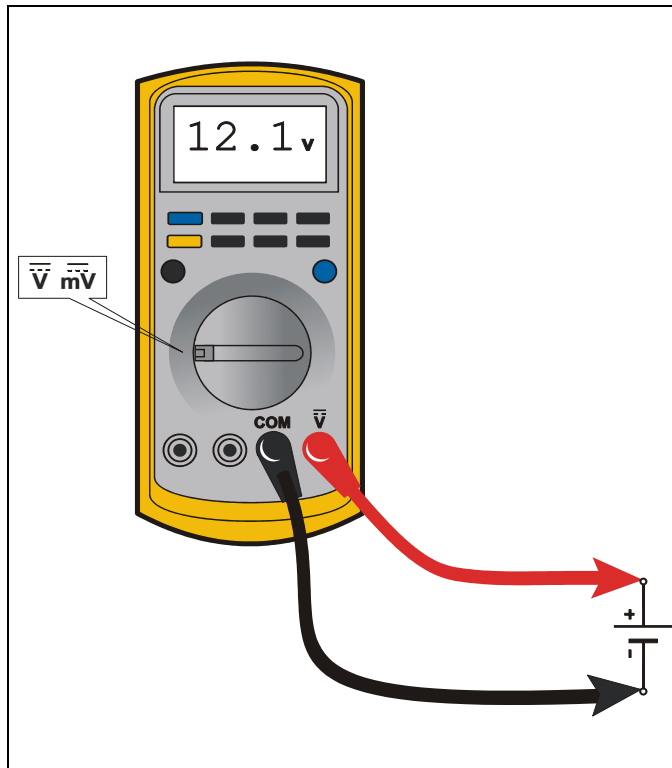
Voltage Measurement**Figure 6-1. Voltage Measurement (DC)**

- If meter is not auto ranging, set it to the correct range (See multimeter's operation manual)
- Use firm contact with meter leads

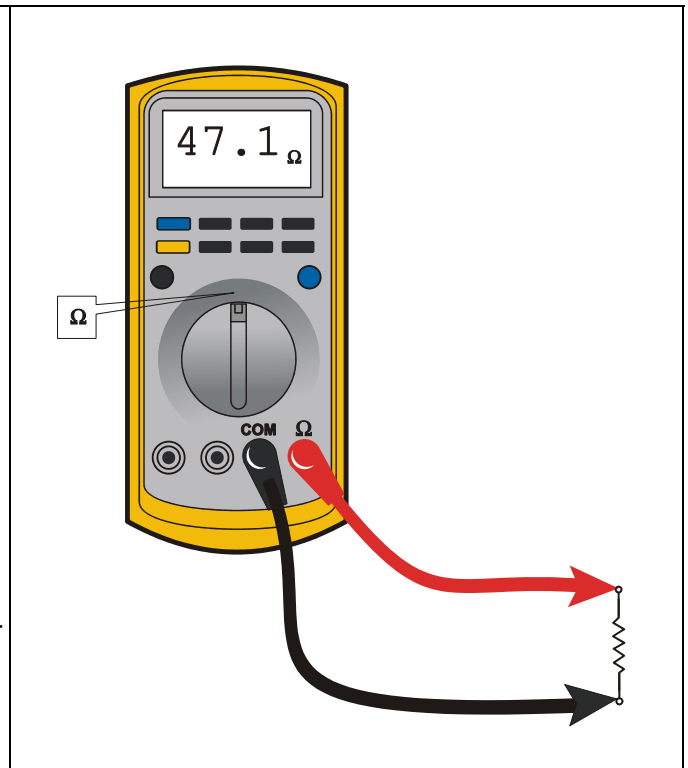
Resistance Measurement**Figure 6-2. Resistance Measurement**

- First test meter and leads by touching leads together. Resistance should read a short circuit (very low resistance)
- Circuit power must be turned OFF before testing resistance
- Disconnect component from circuit before testing
- If meter is not auto ranging, set it to the correct range (See multimeter's operation manual)
- Use firm contact with meter leads

Continuity Measurement

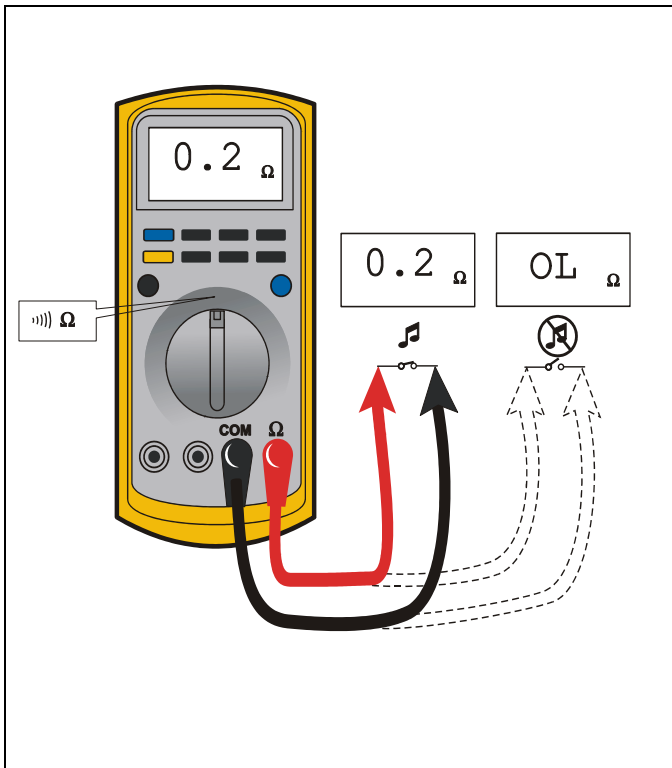

Figure 6-3. Continuity Measurement

- Some meters require a separate button press to enable audible continuity testing
- Circuit power must be turned OFF before testing continuity
- Disconnect component from circuit before testing
- Use firm contact with meter leads
- First test meter and leads by touching leads together. Meter should produce an audible alarm, indicating continuity

Current Measurement

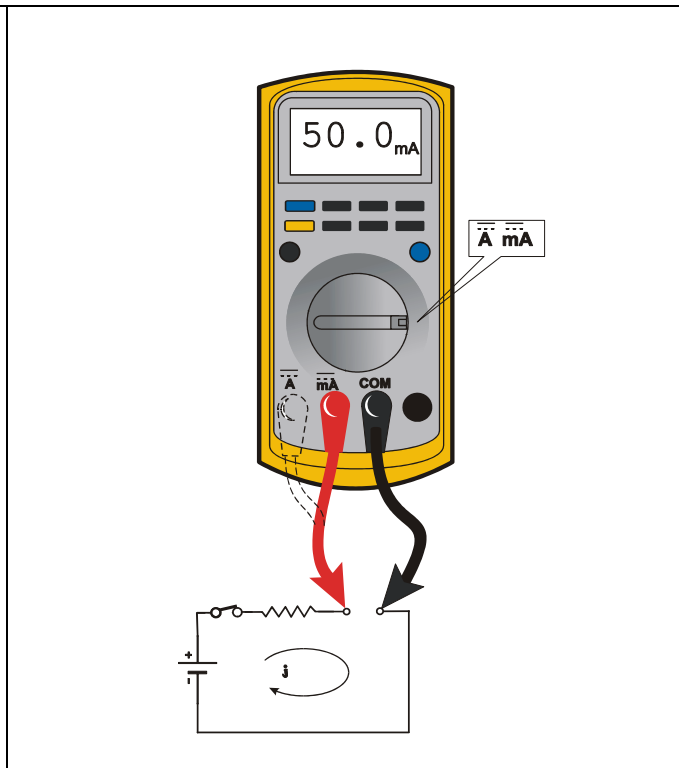

Figure 6-4. Current Measurement (DC)

- Set up the meter for the expected current range
- Be sure to connect the meter leads to the correct jacks for the current range you have selected
- If meter is not auto ranging, set it to the correct range (See multi meter's operation manual)
- Use firm contact with meter leads

Continuity Measurement Over Long Distances

When trying to determine continuity of a harness or wire, longer than the reach of standard instrument leads, is possible to perform the check without excessively long leads. Using the other wires in the harness one can determine the condition of a particular wire in the harness.

Requirements:

- Harness with at least three separate wires including the wire under test.
- These wires must be able to be isolated from other wires, etc.
- Jumper or method to connect contacts on one side of harness.
- Meter that can measure resistance or continuity.

Procedure

Test multimeter leads resistance. Subtract this value from the measured resistance of the wires to get a more accurate measurement.

Consult the circuit schematic to determine which wires to use in addition to wire under test, here called wire #1 and wire #2, and how to isolate these wires. These wires should appear in the same connectors as the wire under test or are within reach of the jumper.

1. Disconnect all connections associated with the wire under test and the two additional wires. If harness is not completely isolated disconnect battery terminals also, as a precaution.
2. Measure continuity between all three wires, the wire under test, wire #1 and wire #2. These should be open. If not, repair the shorted wires or replace the harness.
3. On one side, jumper from contact of wire #1 and wire #2.
4. Measure continuity between wire #1 and wire #2. If there is continuity, both wires are good and can be used for this test. If there is not continuity, either wire could be bad. Check connections and measurement setup. Redo measurement. If still no continuity, repair wires or consult schematic for other wires to use for test.
5. Jumper from wire under test to wire #1.
6. Measure continuity. If there is continuity, the wire under test is good. Resistance of a wire increases as the length increases and as the diameter decreases.

One can find the continuity of two wires, here #1 and #2, at once by following steps 1 through 4. If there is a problem the third wire is used to troubleshoot the other wires. To find the problem, start at step 1 and use the entire procedure.

6.6 ELECTRICAL SWITCH TESTING

Basic Check

The following check determines if the switch is functioning properly, not the circuit in which the switch is placed. A switch is functioning properly when there is continuity between the correct terminals or contacts only when selected.

1. De-energize the circuit.
2. Isolate the switch from the rest of the circuit if possible. If not possible, keep in mind it may affect readings.
3. Access the terminals to the switch.
4. If the switch has two terminals:
 - a. Measure resistance across the terminals.
 - b. Change the switch position.
 - c. Measure resistance again with the leads in the same positions. If the meter was reading short, it should read an open. If the meter was reading open it should read short.
5. If the switch has more than two terminals, consult the schematic or switch diagram to determine what terminals will be connected. The test is similar to testing a switch with two terminals.
 - a. Place one meter lead on the common contact and the other on a different contact in the same circuit.
 - b. Cycle through all positions of the switch. The meter should read short only when the switch connects the two terminals and open otherwise.
 - c. If the switch has more than one common contact repeat the process for that circuit.

Limit Switches

Limit switches are used to control movement or indicate position. Mechanical limit switches are just like manually operated switches except that the moving object operates the switch. These switches can be tested the same way as a standard switch by manually operating the sensing arm.

Another type of limit switch used by JLG is the inductive proximity switch, also referred to as a "prox switch". Inductive proximity switches are actuated only by ferrous metal (metal that contains Iron, such as steel) near the switch. They do not require contact, and must be energized to actuate. These types of switches can be used to detect boom or platform position, for example. These switches have a sensing face where the switch can detect ferrous metal close to it. To find the sensing face, take note how the switch is mounted and how the mechanisms meet the switch. Test this type of switch as follows:

1. Remove prox switch from its mount.
2. Reconnect harness if it was disconnected for step 1, and turn on machine.
3. Hold switch away from metal and observe switch state in the control system diagnostics using the Analyzer. See vehicle or control system documentation on how to do this.
4. Place sensing face of switch on the object to be sensed by the switch. If that is not available, use a piece of ferrous metal physically similar to it. The switch state in the control system diagnostics should change.
5. When reinstalling or replacing switch be sure to follow mounting instructions and properly set the gap between the switch and object sensed.

Automatic Switches

If the switch is actuated automatically, by temperature or pressure for example, find a way to manually actuate the switch to test it. Do this either by applying heat or pressure, for example, to the switch. These switches may need to be energized to actuate.

1. Connect instrumentation to monitor and/or control the parameter the switch is measuring.
2. Observe switch state in control system with the Analyzer. See vehicle or control system documentation on how to do this.
3. Operate system such that the switch actuates. This could be going over a certain pressure or temperature, for example. The state indicated in the control system should change.

Switch Wiring - Low Side, High Side

When controlling a load, a switch can be wired between the positive side of the power source and the load. This switch is called a "high side" switch. The switch supplies the power to the load. When a switch is wired between the negative side of the power source and the load, it is a "low side" switch. The switch provides the ground to the load.

A low side switch will allow voltage to be present on the load. No power is applied because the switch is stopping current flow. This voltage can be seen if the measurement is taken with one test lead on the load and the other on the battery negative side or grounded to the vehicle. What is actually being measured is the voltage drop across the switch. This could mislead a technician into thinking the load is receiving power but not operating. To produce an accurate picture of power or voltage applied to the load, measure voltage across the load's power terminals. Also, the technician can measure the voltage at both power terminals with respect to battery ground. The difference between those two measurements is the voltage applied to the load.

6.7 GROUND CONTROL MODULE LCD DISPLAY

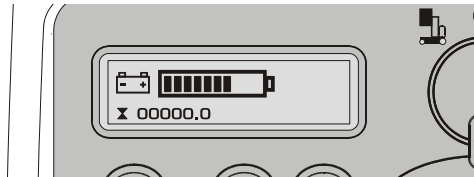

At power-up and during operation the LCD display on the Ground Control Module displays the current machine operating status. The following illustration explains the symbol indications.

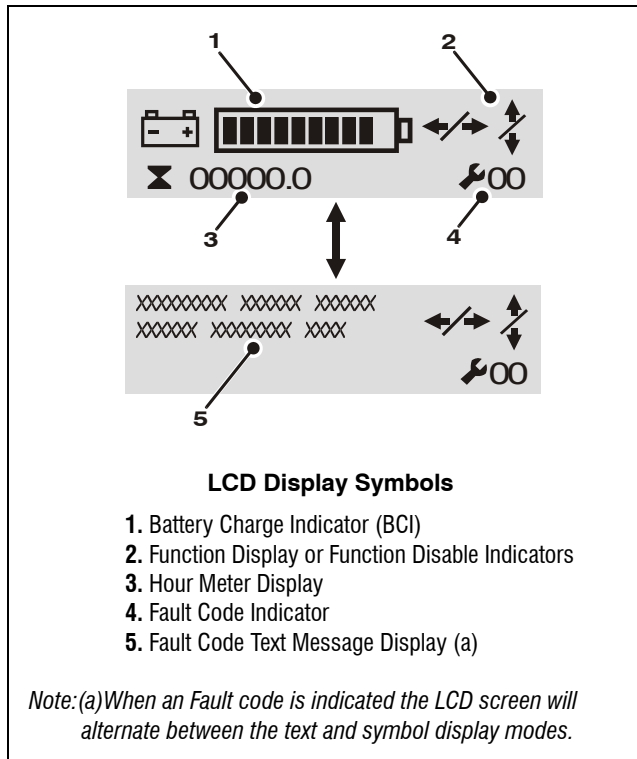

In the LCD Display Symbols illustration item (2) above, the Function Display or Function Disable Indicators will vary as shown following:

	DRIVE Disabled		Both LIFT UP and LIFT DOWN Disabled
	LIFT UP Disabled		Drive Speed Cut-Back (Turtle) Mode Engaged
	LIFT DOWN Disabled		Battery Charger Plugged In

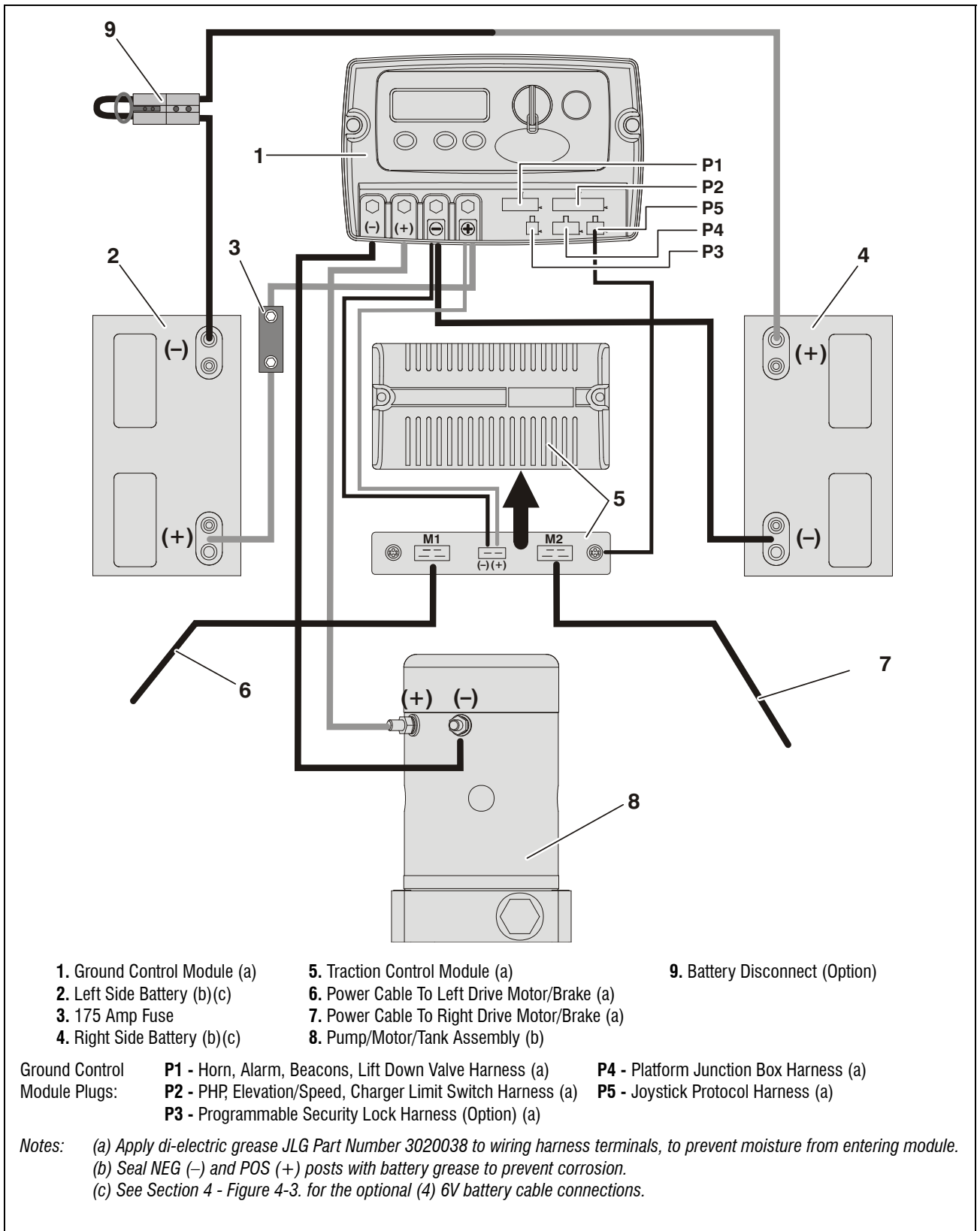

Figure 6-5. Component Electrical Connections.

SECTION 6 - TROUBLESHOOTING

Table 6-1. LCD Display - Service Fault Code Conditions

FAULT CODE	PLATFORM CONSOLE LEDs FLASHING	LCD SYMBOL SCREEN	LCD TEXT SCREEN	FAULT DESCRIPTION/ MACHINE CONDITION	TROUBLESHOOTING
—	—		—	Machine In Drive Speed Cut-Back (Turtle) Mode All The Time	See Table 6-5, Page 6-17
—	—		BRAKES RELEASED	Brakes Released DRIVE Disabled	Engage Brakes - Press Brake Release Button on Ground Control Station
—	—		—	Charger AC Plugged In DRIVE Disabled	Unplug Charger AC Input Power Cord from Machine
—	—		OBSTRUCTION BELOW PLATFORM	Obstruction Sensor System (Platform Elevated) LIFT DOWN Disabled	See Table 6-6, Page 6-18
—	—		ENTER SECURITY CODE	Programmable Security Lock Password	Type in Code At PSL Key Pad See Operators Manual for Proper Operation
—	1		LOW BATTERY	Low Battery Voltage	See Page 6-18
02	2		LEFT PHP BAR UP	Left PHP Bar UP (Platform Elevated) DRIVE and Lift UP Disabled	See Table 6-7, Page 6-19
03	2		RIGHT PHP BAR UP	Right PHP Bar UP (Platform Elevated) DRIVE and Lift UP Disabled	See Table 6-8, Page 6-19
04	3		TILTED	Tilt Condition (Platform Elevated) DRIVE and Lift UP Disabled	See Table 6-9, Page 6-20
05	—	RESERVED		RESERVED	
06	8			Drive Motor Brush Wear Warning (Counts down 25 hrs. of DRIVE operation remaining to a 10 sec. shut down mode)	See Table 6-10, Page 6-21
07	6		LEFT MOTOR DISCONNECTED	Left Drive Motor Disconnected DRIVE Disabled	See Table 6-11, Page 6-21
08	6		RIGHT MOTOR DISCONNECTED	Right Drive Motor Disconnected DRIVE Disabled	See Table 6-12, Page 6-22

Table 6-1. LCD Display - Service Fault Code Conditions

FAULT CODE	PLATFORM CONSOLE LEDs FLASHING	LCD SYMBOL SCREEN	LCD TEXT SCREEN	FAULT DESCRIPTION/MACHINE CONDITION	FOR TROUBLESHOOTING REFER TO
09	6			Left Brake Disconnected DRIVE, Lift UP/DOWN Disabled	See Table 6-13, Page 6-22
10	6			Right Brake Disconnected DRIVE, Lift UP/DOWN Disabled	See Table 6-14, Page 6-22
11	6			Left Drive Motor Short Circuit DRIVE Disabled	See Table 6-15, Page 6-23
12	6			Right Drive Motor Short Circuit DRIVE Disabled	See Table 6-16, Page 6-23
13	6			Traction Module In Fold Back DRIVE Disabled	See Table 6-17, Page 6-23
14	7			Pump Motor Disconnected Lift UP Disabled	See Table 6-18, Page 6-24
15	7			Lift Down Valve Disconnected Lift UP/DOWN Disabled	See Table 6-19, Page 6-24
16	7			Down Valve or Down Valve Circuit Short Lift UP/DOWN Disabled	See Table 6-20, Page 6-25
17	7			Ground Control Module In Fold Back (Machine Stopped)	See Table 6-21, Page 6-25
18	—			Alarm or Alarm Circuit Short	See Table 6-22, Page 6-25
19	—			Alarm Disconnected	See Table 6-23, Page 6-26
20	—			Beacon or Beacon Circuit Short	See Table 6-24, Page 6-26
21	—			Beacon Disconnected	See Table 6-25, Page 6-27

SECTION 6 - TROUBLESHOOTING

Table 6-1. LCD Display - Service Fault Code Conditions











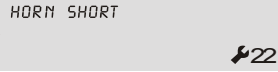



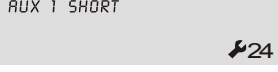

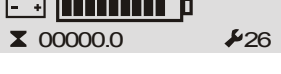
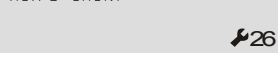
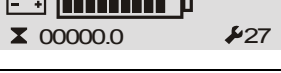

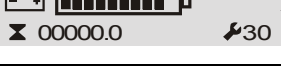

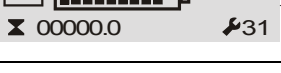

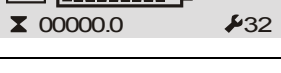
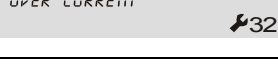
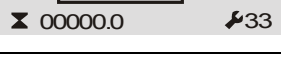

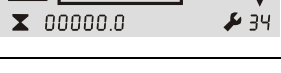

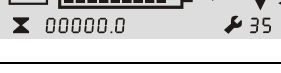



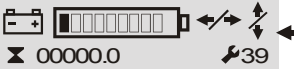
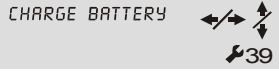

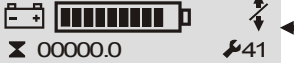



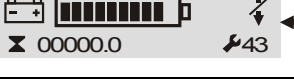

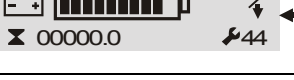

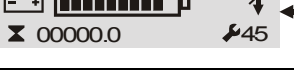

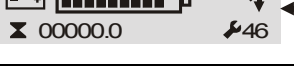
FAULT CODE	PLATFORM CONSOLE LEDs FLASHING	LCD SYMBOL SCREEN	LCD TEXT SCREEN	FAULT DESCRIPTION/MACHINE CONDITION	FOR TROUBLESHOOTING REFER TO
22	—			Horn or Horn Circuit Short	See Table 6-26, Page 6-27
23	—			Horn Disconnected	See Table 6-27, Page 6-28
24	—			Auxiliary #1 Circuit Short	See Table 6-28, Page 6-28
25	—			Auxiliary #1 Circuit Disconnected	See Table 6-29, Page 6-29
26	—			Auxiliary #2 Circuit Short	See Table 6-30, Page 6-29
27	—			Auxiliary #2 Circuit Disconnected	See Table 6-31, Page 6-30
30	6			Traction Module No Communication with Ground Control Module	See Table 6-32, Page 6-30
31	—			Platform Control Console No Communication with Ground Control Module	See Table 6-33, Page 6-31
32	7			Pump Motor Over Current LIFT UP Disabled	See Table 6-34, Page 6-31
33	2			Both PHP Bars UP DRIVE and Lift UP Disabled	See Table 6-35, Page 6-32
34	—			P2-Auxiliary #1 - Inhibit LIFT UP/DOWN and DRIVE are Disabled	See Table 6-36, Page 6-32
35	—			P2-Auxiliary #1 - Tie Down LIFT UP/DOWN and DRIVE are Disabled	See Table 6-37, Page 6-32
38	2			2 LEDs/BARS Flashing with an audible beep. Platform Lift-UP Function is Locked Out.	See Page 6-33

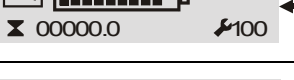
Table 6-1. LCD Display - Service Fault Code Conditions

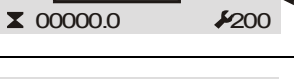
FAULT CODE	PLATFORM CONSOLE LEDs FLASHING	LCD SYMBOL SCREEN	LCD TEXT SCREEN	FAULT DESCRIPTION/MACHINE CONDITION	FOR TROUBLESHOOTING REFER TO
39	1			1 LED/BAR Flashing with an audible beep. Drive and Platform Lift-UP Functions Locked Out.	See Page 6-33
40	5			Obstruction Sensor System No Communication With Ground Control Station	See Table 6-38, Page 6-34
41	—			Internal OSS Sensor #1 Fault Condition	See Table 6-39, Page 6-35
42	—			Internal OSS Sensor #2 Fault Condition	See Table 6-39, Page 6-35
43	—			Internal OSS Sensor #3 Fault Condition	See Table 6-39, Page 6-35
44	—			Internal OSS Sensor #4 Fault Condition	See Table 6-39, Page 6-35
45	—			Internal OSS Sensor #5 Fault Condition	See Table 6-39, Page 6-35
46	—			Internal OSS Sensor #6 Fault Condition	See Table 6-39, Page 6-35
100	10			Ground Control Module Fault Condition	See Table 6-40, Page 6-36
200	10			Platform Control Console Fault Condition	See Table 6-41, Page 6-37
300	10			Traction Control Module Fault Condition	See Table 6-42, Page 6-38
400	—			OSS Control Module Low Internal Supply	See Table 6-38, Page 6-34
401	—			OSS Control Module Amplifier Fault	See Table 6-38, Page 6-34

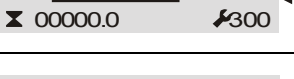
6.8 TROUBLESHOOTING TABLES INDEX

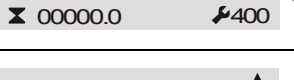
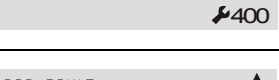
SPECIFICATIONS FOR VARIOUS COMPONENTS

PAGE

Ohm Ratings for Various Components	6-16
Amperage Draw for Various Components	6-16

SPECIAL PIN EXTRACTOR TOOLS FOR ELECTRICAL CONNECTORS

Special Pin Extractor Tools for Electrical Connectors	6-16
---	------

FAULT CODE TROUBLESHOOTING TABLES

Machine in Drive Speed Cut-Back (Turtle) Mode All The Time	6-17
Obstruction Sensor System - Detection	6-18
Battery Voltage Low - Warning Level 3 - Three (3) LED/LCDs lit	6-18
Code 02 - Left PHP Bar - UP	6-19
Code 03 - Right PHP Bar - UP	6-19
Code 04 - Tilt Condition	6-20
Code 05 - Reserved	6-20
Code 06 - Drive Motor Brush Wear Warning Indicator	6-21
Code 07 - Left Drive Motor - Disconnected	6-21
Code 08 - Right Drive Motor - Disconnected	6-22
Code 09 - Left Brake - Disconnected	6-22
Code 10 - Right Brake - Disconnected	6-22
Code 11 - Left Drive Motor - Short Circuit	6-23
Code 12 - Right Drive Motor - Short Circuit	6-23
Code 13 - Traction Module - In Fold Back	6-23
Code 14 - Pump Motor - Disconnected	6-24
Code 15 - Lift Down Valve - Disconnected	6-24
Code 16 - Lift Down Valve - Short Circuit	6-25
Code 17 - Ground Control Module - In Fold Back	6-25
Code 18 - Alarm - Short Circuit	6-25
Code 19 - Alarm - Disconnected	6-26
Code 20 - Beacon - Short Circuit	6-26
Code 21 - Beacon - Disconnected	6-27
Code 22 - Horn - Short Circuit	6-27
Code 23 - Horn - Disconnected	6-28
Code 24 - Auxiliary #1 Circuit - Short Circuit	6-28
Code 25 - Auxiliary #1 Circuit - Disconnected	6-29
Code 26 - Auxiliary #2 - Short Circuit	6-29
Code 27 - Auxiliary #2 - Disconnected	6-30
Code 28 - Reserved	6-30
Code 29 - Reserved	6-30
Code 30 - Traction Module - No Communication with Ground Control Module	6-30
Code 31 - Platform Control Console - No Communication with Ground Control Module	6-31

Code 33 - Both PHP Bars - UP	6-32
Code 34 - P2-Auxiliary #1 - Inhibit	6-32
Code 35 - P2-Auxiliary #1 - Tie Down	6-32
Code 38 - Battery Voltage Low - Warning Level 2 - Two (2) LED/LCDs lit	6-33
Code 39 - Battery Voltage Low - Warning Level 3 - One (1) LED/LCDs lit	6-33
Code 40 - Obstruction Sensor System - No Communication with Ground Control Module	6-34
Codes 41 thru 46 - OSS - Sensor 1 through 6 - Fault Condition	6-35
Codes (100 - 199) Ground Control Module - Fault Condition	6-36
Codes (200 - 299) Platform Control Console - Fault Condition	6-37
Codes (300 - 399) Traction Control Module - Fault Condition	6-38

MAIN POWER CIRCUIT TROUBLESHOOTING

Machine Will Not Power Up	6-39
-------------------------------------	------

MAST TROUBLESHOOTING

Platform Will Not Lower Manually	6-40
Platform Lift Up And Down - Jerky	6-40
Mast Noisy When Lifting And Lowering	6-41
Platform (Mast) Won't Stay Elevated	6-42
Platform (Mast) Descends Too Slowly	6-42

HYDRAULIC LEAK TROUBLESHOOTING

Miscellaneous Hydraulic Leak Troubleshooting	6-43
--	------

BASE FRAME COMPONENTS TROUBLESHOOTING

Caster Wheels Not Operating Freely	6-44
Pot Hole Protection (PHP) Bars will not Lower	6-44

DRIVE SYSTEM TROUBLESHOOTING

Won't Climb Grade	6-45
Machine Drives in Opposite Direction	6-45
Machine Won't Drive Straight	6-46
Noise From Drive Assembly	6-47

6.9 SPECIFICATIONS FOR VARIOUS COMPONENTS

The following table contains specifications for MVL Series and MSP machine components.

Table 6-2. Ohm Ratings for Various Components

COMPONENT	NOMINAL RESISTANCE @ TEMPERATURE	RESISTANCE RANGE POSSIBLE
Pump Motor	0.2ohm - 0.4ohm @ 77deg F	0.12ohm - 0.49ohm

Table 6-3. Amperage Draw for Various Components

COMPONENT	AMPERAGE		
Ground Control Module	20MVL - 95 Amps @ room temperature with rated load 15MSP - 110 Amps @ room temperature with rated load		
Traction Control Module	LEVEL SURFACE (24V) (RATED LOAD)	15% GRADE (24V) (RATED LOAD)	NO LOAD (24V)
	7 to 11 Amps (per motor)	55 to 60 Amps (per motor)	3.5 to 4.8 Amps 78 to 86 RPM

6.10 SPECIAL PIN EXTRACTOR TOOLS FOR ELECTRICAL CONNECTORS

The following table contains pin extractor tools for MVL/MVL Series and MSP machine electrical connector components.

Table 6-4. Special Pin Extractor Tools for Electrical Connectors

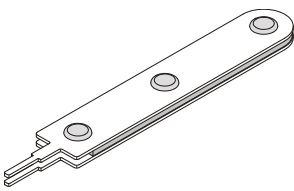
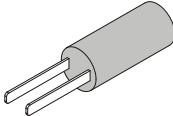
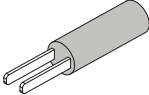
COMPONENT	DESCRIPTION	JLG PART NUMBER	ILLUSTRATION
Ground Control Station	For removal of electrical connector pins from the Ground Control Station connectors.	7016618	
Drive Motor	For removal of electrical connector pins from the Drive Motor main power connectors.	7002841	
Drive Motor Brake	For removal of electrical connector pins from the Drive Motor Brake power connectors.	7002842	

6.11 FAULT CODE TROUBLESHOOTING TABLES

Machine in Drive Speed Cut-Back (Turtle) Mode All The Time

Overview of Procedure

Under normal machine operation once the platform is elevated the machine's maximum drive speed is reduced to 1/4 the normal drive speed of when the platform is fully lowered. This is detected with a drive speed cut-back (*proximity*) switch mounted at the base of the mast assembly and a target mounted on the mast assembly. When the mast is elevated and the target raised the proximity switch then cuts back the machine drive speed. When machine is in the drive speed cut-back mode a turtle is displayed on the Ground Control Module LCD display.

Check For These Obvious Conditions First:

- Mast drive speed cut-back (proximity) switch and target plate secure and undamaged.
- Both Pot Hole Protection Bar Limit switches secure and undamaged.

Table 6-5. Machine In Drive Speed Cut-Back (Turtle) Mode All The Time

STEP	ACTION	SPEC	YES	NO
1.	The Pot-Hole-Protection system bars should be raised when the platform is fully lowered. Check if the Pot-Hole-Protection bars are down when the platform is fully lowered.	—	Check the mechanical operation of the PHP System	Go to Step 2
2.	With the platform fully lowered, check for continuity on the Cutback Proximity Switch wires between pins-8 and 18 on the P2 connector at the Ground Control Module.	—	Go to Step 3	Repair or Replace Speed Cutback (Proximity) Switch
3.	With the platform fully lowered, bars raised, check for continuity on the Right Side PHP bar limit switch, between pins-9 and 19 on the P2 connector at the Ground Control Module.	—	Repair or Replace Right Side PHP Limit Switch Go to Step 4	
4.	With the platform fully lowered, bars raised, check for continuity on the Left Side PHP bar limit switch, between pins-10 and 20 on the P2 connector at the Ground Control Module.	—	Repair or Replace Left Side PHP Limit Switch	

Obstruction Sensor System - Detection

Check For These Obvious Conditions First:

- Look for an obstruction under platform, remove obstruction.
- Check for any external damage to sensor(s) or wiring harness.
- Are the O.S.S. side shield tubes secure to platform frame and not loose or protruding into the sensor detection area?
- Are the isolation bushings in place and undamaged on both the O.S.S. Module and each of the detection sensors?
- Are the detection sensor mounting screws properly tightened (*not over torqued*) so not to damage the isolation bushings? Also check that none of the sensor mounting screws are bent, thereby touching the inside of the sensor mounting holes.
- Are any of the "Do not pressure wash" decals loose and protruding into the sensor detection area?

Table 6-6. Obstruction Sensor System - Detection

STEP	ACTION	SPEC	YES	NO
1.	Perform Daily Pre-Start Inspection to test each transducer sensor. Did all sensors pass test?	—	Go to Step 2	Replace Sensor
2.	Disconnect the OSS Control Module connection to the Platform Junction Box mounted on the mast platform header section above the OSS Control Module. Does the Ground Control Module now show a Fault Code 5?	—	Go to Step 3	Replace Ground Control Module
3.	Reconnect the OSS Control Module connection to the Platform Junction Box. Check for original fault condition.	—	Replace OSS System	—

 **Battery Voltage Low - Warning Level 3 - Three (3) LED/LCDs lit**

- 3 LEDs/BARS Flashing with an audible beep.
- Machine will Operate - No Control Functions are Locked Out.

When batteries are drained to Warning Level 3, charge batteries until a level of four (4) LEDs-(Platform) or BARS (Ground Control Module), or more before operating. Failure to do so, will eventually result in a fault Code 38 - Battery Voltage Low - Warning Level 2.

NOTE: If battery is not charging properly, see *Battery/Battery Charger Servicing - Section 3 of this Manual.*

Code 02 - Left PHP Bar - UP

Check For These Obvious Conditions First:

- Obstruction under LEFT pot hole bar.
- Obstruction around the actuator assembly at the base of the mast.

Table 6-7. Code 02 - Left PHP Bar - UP

STEP	ACTION	SPEC	YES	NO
CHECK THE FOLLOWING WITH THE PLATFORM ELEVATED 3 TO 4 FEET (1 TO 1.5m)				
1.	Go to the 20 pin molex connector at the Ground Control Module, back probe to check for continuity of pin 10, (BLK #8 wire) with pin 20, (ORG/RED 49-1 wire). Is there continuity?	—	Replace Ground Control Module	Go to Step 2
2.	Check the actuator cables for adjustment or damage.	—	Adjust or Replace	Go to Step 3
3.	Check the PHP limit switch(s) at both sides of the machine for damage, adjustment and for continuity through switch to ground when bars are down.	—	Replace, Adjust or Repair Wiring	—

Code 03 - Right PHP Bar - UP

Check For These Obvious Conditions First:

- Obstruction under RIGHT pot hole bar.
- Obstruction around the actuator assembly at the base of the mast.

Table 6-8. Code 03 - Right PHP Bar - UP

STEP	ACTION	SPEC	YES	NO
CHECK THE FOLLOWING WITH THE PLATFORM ELEVATED 3 TO 4 FEET (1 TO 1.5m)				
1.	Go to the 20 pin molex connector at the Ground Control Module, back probe to check for continuity of pin 9, (BLK #9 wire) with pin 19, (ORG/RED 49-2 wire). Is there continuity?	—	Replace Ground Control Module	Go to Step 2
2.	Check the actuator cables for adjustment or damage.	—	Adjust or Replace	Go to Step 3
3.	Check the PHP limit switch(s) at both sides of the machine for damage, adjustment and for continuity through switch to ground when bars are down.	—	Replace, Adjust or Repair Wiring	—

SECTION 6 - TROUBLESHOOTING

Code 04 - Tilt Condition

Check For These Obvious Conditions First:

- If machine is on a tilt of more than 1.5° in either or both the X or Y direction, this is normal operation. (DRIVE and LIFT UP are disabled when tilt is detected)
- Check if Ground Control Module is mounted securely to the mast support column.

Table 6-9. Code 04 - Tilt Condition

STEP	ACTION	SPEC	YES	NO
1.	Using a digital level check the actual level of the machines' resting surface in both the X and the Y directions. Does surface check within machine specification.	1.5° X and Y Direction	Go to Step 2	Drive Machine to Level Surface
2.	At the Ground Control Module, enter the programming mode (See Ground Control Programming, Section-3 of Service Manual) and check the tilt sensor X and Y readings. Are readings within machine specification?	1.5° X and Y Direction	Replace Ground Control Module	Go to Step 3
3.	Zero Tilt Sensor on a surface checked to within 0.0 degrees with a digital level in both the X and Y directions. (See Ground Control Programming, Section-3 of Service Manual).	—	—	—

NOTE: If frequent calibration of the internal Tilt Sensor is required, replace the Ground Control Module.

Code 05 - Reserved

Code 06 - Drive Motor Brush Wear Warning Indicator

Check For These Obvious Conditions First:

- Did the Brush Wear Indication relay get wet. If so, dry the relay and wire terminals and reset the Brush Wear Warning Timer.
- Program Ground Control Station module to reset the Brush Wear Warning Timer - see Section 4.6, Ground Control Module - Programming.
- If machine has accumulated a lot of hours in service since new or the last brush replacement, check the Drive Motor Brushes - see Section 3, Replacing Drive Motor Brushes - for brush replacement instructions.

Table 6-10. Code 06 - Drive Motor Brush Wear Warning Indicator

STEP	ACTION	SPEC	YES	NO
1.	If the WORN code immediately comes up again after resetting, then check the voltage at the brush wear indication relay where the wires (wht/red 57-1 and 57-2) from the drive motors connect at terminal (#85). If there is voltage on relay terminal #85, you have a problem with the motor.... check for voltage at the terminals at the motor to determine which motor has the bad brushes	0 Volts	Problem is in motor, brushes need replacement	Go To Step 2
2.	If there is no voltage at terminal #85 on the wear indication relay, and there is voltage on relay terminal #87, you have a problem with the relay or the wiring	—	Check relay or wiring	Go to Step 3
3.	If there is no voltage at relay terminal #85, and there is no voltage on relay terminal #87, you have a problem with the wiring or controller if the code immediately repeats	—	Replace wiring or GCM	—

Code 07 - Left Drive Motor - Disconnected

Check For These Obvious Conditions First:

- Check left drive motor M1 connector at the Traction Control Module for secure and proper connection.

Table 6-11. Code 07 - Left Drive Motor - Disconnected

STEP	ACTION	SPEC	YES	NO
1.	Check resistance across positive (+) and negative (-) drive motor leads in M1 connector wiring harness going to the left drive motor. Is reading within spec?	.1 to .3 ohms	Replace Traction Module	Go to Step 2
2.	Repair or replace left drive motor wiring, brushes or motor. (For brush replacement, see Section 3 of this Service Manual)	—	—	—

 **Code 08 - Right Drive Motor - Disconnected**

Check For These Obvious Conditions First:

- Check right drive motor M2 connector at the Traction Control Module for secure and proper connection.

Table 6-12. Code 08 - Right Drive Motor Disconnected

STEP	ACTION	SPEC	YES	NO
1.	Check resistance across positive (+) and negative (-) leads in M2 connector wiring harness going to the right drive motor. Is reading within spec?	.1 to .3 ohms	Replace Traction Module	Go to Step 2
2.	Repair or replace right drive motor wiring, brushes or motor. (For brush replacement, see Section 3 of this Service Manual)	—	—	—

 **Code 09 - Left Brake - Disconnected**

Check For These Obvious Conditions First:

- Check left drive motor M1 connector at the Traction Control Module for secure and proper connection.

Table 6-13. Code 09 - Left Brake - Disconnected

STEP	ACTION	SPEC	YES	NO
1.	Check resistance across positive (+) and negative (-) leads in M1 connector wiring harness going to the left drive motor brake assembly. Is reading within spec?	See Table 6-2	Replace Traction Module	Go to Step 2
2.	Repair or replace left brake wiring or left brake assembly.	—	—	—

 **Code 10 - Right Brake - Disconnected**

Check For These Obvious Conditions First:

- Check right drive motor M2 connector at the Traction Control Module for secure and proper connection.

Table 6-14. Code 10 - Right Brake - Disconnected

STEP	ACTION	SPEC	YES	NO
1.	Check resistance across positive (+) and negative (-) leads in M2 connector wiring harness going to the right drive motor brake assembly. Is reading within spec?	See Table 6-2	Replace Traction Module	Go to Step 2
2.	Repair or replace right brake wiring or right brake assembly.	—	—	—

Code 11 - Left Drive Motor - Short Circuit

Check For These Obvious Conditions First:

- Wiring harness from (M1) connector on Traction Control Module to Left Drive Motor for damage.

Table 6-15. Code 11 - Left Drive Motor - Short Circuit

STEP	ACTION	SPEC	YES	NO
1.	Remove the M1 connector from the Traction Control Module and check both the pins to the drive motor for any voltage. (Ground the meter to the Ground Control Module - Negative (-) lug.)	No Voltage	This circuit should be isolated. Repair or Replace Components as Required	Go to Step 2
2.	Check for continuity of both the pins to ground.	No Ground		Replace Traction Control Module

Code 12 - Right Drive Motor - Short Circuit

Check For These Obvious Conditions First:

- Wiring harness from (M2) connector on Traction Control Module to Left Drive Motor for damage.

Table 6-16. Code 12 - Right Drive Motor - Short Circuit

STEP	ACTION	SPEC	YES	NO
1.	Remove the M2 connector from the Traction Control Module and check both the pins to the drive motor for any voltage. (Ground the meter to the Ground Control Module - Negative (-) lug.)	No Voltage	This circuit should be isolated. Repair or Replace Components as Required	Go to Step 2
2.	Check for continuity of both the pins to the drive motor to ground.	No Ground		Replace Traction Control Module

Code 13 - Traction Module - In Fold Back

Check For These Obvious Conditions First:

- Machine is operating on a continuous grade or rough terrain.

Table 6-17. Code 13 - Traction Module - In Fold Back

STEP	ACTION	SPEC	YES	NO
1.	Allow machine to cool the traction module for 30 minutes. Does the machine operate OK after cooling.	—	—	Replace Traction Module
NOTE: If this is a recurring problem compare current draw of your machine with Traction Control Module specifications in Table 6-3 - Amperage Draw for Various Components.				

 **Code 14 - Pump Motor - Disconnected**

Check For These Obvious Conditions First:

- Check the Positive (+)/Negative (-) cables from the Ground Control Module to the Pump Motor studs for loose or corroded connections.

Table 6-18. Code 14 - Pump Motor - Disconnected

STEP	ACTION	SPEC	YES	NO
1.	Check resistance across the positive (+) and negative (-) studs on the pump motor.	See Table 6-2	Replace Ground Control Module	Repair or Replace Pump Motor or Motor Brushes

 **Code 15 - Lift Down Valve - Disconnected**

Check For These Obvious Conditions First:

- Inspect wire terminals on the lift down valve at the base of the lift cylinder for tight and secure connection.

Table 6-19. Code 15 - Lift Down Valve - Disconnected

STEP	ACTION	SPEC	YES	NO
1.	Check voltage at the P1 connector on the Ground Control Module between pin-10 and pin-3. Is reading within spec?	2 - 4 VDC	Replace Ground Control Module	Go to Step 2
2.	Check resistance between the terminals on the lift down valve, located at the base of the lift cylinder. Is reading within spec?	6 Ohms	Repair or Replace Wiring Harness from Ground Control Module	Replace the Lift Down Valve Solenoid
3.	With the terminals still removed from the lift down valve coil, check continuity of the wires from pins 10 and 3 on the P1 connector to the lift down valve.	.00 Ohms	—	Repair or Replace Wiring

Code 16 - Lift Down Valve - Short Circuit

Check For These Obvious Conditions First:

- Damaged wiring in the lift down valve wiring harness or a damaged lift down valve coil.

Table 6-20. Code 16 - Lift Down Valve - Short Circuit

STEP	ACTION	SPEC	YES	NO
1.	At the Ground Control Module, P1 connector, check the voltage across pins 10 and 3 to the lift down valve coil. Is reading within specification?	0 - 2V DC	Go to Step 2	Replace Ground Control Module
2.	Remove the wire terminals at the lift down valve coil. Check resistance reading of the coil. Is coil within specification?	6 Ohms	Go to Step 3	Replace Coil
3.	With the terminals still removed from the lift down valve coil, check continuity of the wires from pins 10 and 3 on the P1 connector to the lift down valve.	.00 Ohms	—	Repair or Replace Wiring

Code 17 - Ground Control Module - In Fold Back

Check For These Obvious Conditions First:

- Has machine been operating on a continuous grade or rough terrain for a long period of time.

Table 6-21. Code 17 - Ground Control Module - In Fold Back

STEP	ACTION	SPEC	YES	NO
1.	Allow Ground Control Module to cool for 30 minutes. Does the machine operate OK after cooling.	—	—	Replace Ground Control Module
NOTE: If this is a recurring problem compare current draw of your machine with Ground Control Module specifications in Table 6-3 - Amperage Draw for Various Components.				

Code 18 - Alarm - Short Circuit

Check For These Obvious Conditions First:

- Damaged wiring in the alarm wiring harness or a damaged alarm.

Table 6-22. Code 18 - Alarm - Short Circuit

STEP	ACTION	SPEC	YES	NO
1.	At the Ground Control Module, P1 connector, check the voltage across pins-13 and 6 to the alarm. Is reading within specification?	0 - 2V DC	Go to Step 2	Replace Ground Control Module
2.	Remove the wire terminals at the alarm, check continuity of each of the wires from pins 13 and 6 on the P1 connector to the alarm end.	—	Replace the Alarm	Repair or Replace Wiring

 **Code 19 - Alarm - Disconnected**

Check For These Obvious Conditions First:

- Damaged wiring in the alarm wiring harness or a damaged alarm.
- Activate a function to check if alarm beeps.

Table 6-23. Code 19 - Alarm - Disconnected

STEP	ACTION	SPEC	YES	NO
1.	Check voltage at the P1 connector on the Ground Control Module between pin-13 and pin-6. Is reading within specification?	2 - 4V DC	Replace Ground Control Module	Go to Step 2
2.	Remove the wire terminals at the alarm, check continuity of each of the wires from pins 13 and 6 on the P1 connector to the alarm end.	—	Replace the Alarm	Repair or Replace Wiring

 **Code 20 - Beacon - Short Circuit**

Check For These Obvious Conditions First:

- Damaged wiring in the beacon wiring harness or a damaged beacon unit.

Table 6-24. Code 20 - Beacon - Short Circuit

STEP	ACTION	SPEC	YES	NO
1.	At the Ground Control Module, P1 connector, check the voltage across pins-12 and 5 to the beacon. Is reading within specification?	0 - 2V DC	Go to Step 2	Replace Ground Control Module
2.	Remove the wire terminals at the beacon, check continuity of each of the wires from pins 12 and 5 on the P1 connector to the beacon end.	—	Replace the Beacon	Repair or Replace Wiring

Code 21 - Beacon - Disconnected

Check For These Obvious Conditions First:

- Is machine equipped with flashing amber beacon light.

Table 6-25. Code 21 - Beacon - Short Disconnected

STEP	ACTION	SPEC	YES	NO
1.	Is machine equipped with a flashing amber beacon light.	—	Go to Step 3	Got to Step 2
2.	At the Ground Control Module enter the programming mode, check if the Beacon light open circuit detection is enabled.	—	Disable It	Replace Ground Control Module
3.	Check voltage at the P1 connector on the Ground Control Module between pin-12 and pin-5. Is reading within specification?	2 - 4 VDC	Replace Ground Control Module	Go to Step 4
4.	Remove the wire terminals at the beacon, check continuity of each of the wires from pins-12 and 5 on the P1 connector to the beacon end.	—	Replace the Beacon	Repair or Replace Wiring

Code 22 - Horn - Short Circuit

Check For These Obvious Conditions First:

- Damaged wiring in the horn wiring harness or a damaged horn unit.

Table 6-26. Code 22 - Horn - Short Circuit

STEP	ACTION	SPEC	YES	NO
1.	At the Ground Control Module, P1 connector, check the voltage across pins-14 and 7 to the horn. Is reading within specification?	0 - 2V DC	Go to Step 2	Replace Ground Control Module
2.	Remove the wire terminals at the horn, check continuity of each of the wires from pins-14 and 7 on the P1 connector to the horn end.	—	Replace the Horn	Repair or Replace Wiring

 **Code 23 - Horn - Disconnected**

Check For These Obvious Conditions First:

- Is machine equipped with a horn unit.

Table 6-27. Code 23 - Horn - Disconnected

STEP	ACTION	SPEC	YES	NO
1.	Is machine equipped with a horn unit.	—	Go to Step 3	Go to Step 2
2.	At the Ground Control Module enter the programming mode, check if the horn open circuit detection is enabled.	—	Disable It	Replace Ground Control Module
3.	Check voltage at the P1 connector on the Ground Control Module between pin-14 and pin-7. Is reading within specification?	2 - 4 VDC	Replace Ground Control Module	Go to Step 4
4.	Remove the wire terminals at the horn, check continuity of each of the wires from pins-14 and 7 on the P1 connector to the horn end.	—	Replace the Horn	Repair or Replace Wiring

 **Code 24 - Auxiliary #1 Circuit - Short Circuit**

Check For These Obvious Conditions First:

- Damaged wiring in the Auxiliary #1 Component wiring harness or a damaged Component.

Table 6-28. Code 24 - Auxiliary #1 Circuit - Short Circuit

STEP	ACTION	SPEC	YES	NO
1.	At the Ground Control Module, P1 connector, check the voltage across pins-9 and 2 to the horn. Is reading within specification?	0 - 2V DC	Go to Step 2	Replace Ground Control Module
2.	Remove the wire terminals at the horn, check continuity of each of the wires from pins-9 and 2 on the P1 connector to the component end.	—	Replace the Component	Repair or Replace Wiring

Code 25 - Auxiliary #1 Circuit - Disconnected

Check For These Obvious Conditions First:

- Is machine equipped with a component on the Auxiliary #1 circuit.

Table 6-29. Code 25 - Auxiliary #1 Circuit - Disconnected

STEP	ACTION	SPEC	YES	NO
1.	Is machine equipped with a component on the Auxiliary #1 circuit.	—	Go to Step 3	Got to Step 2
2.	At the Ground Control Module enter the programming mode, check if the Auxiliary #1 open circuit detection is enabled.	Default = NO	Disable It	Replace Ground Control Module
3.	Check voltage at the P1 connector on the Ground Control Module between pin-9 and pin-2. Is reading within specification?	2 - 4 VDC	Replace Ground Control Module	Go to Step 4
4.	Remove the wire terminals at the Aux. #1 component, check continuity of each of the wires from pins-9 and 2 on the P1 connector to the Aux. #1 component.	—	Replace the Component	Repair or Replace Wiring

Code 26 - Auxiliary #2 - Short Circuit

Check For These Obvious Conditions First:

- Damaged wiring in the Auxiliary #2 Component wiring harness or a damaged Component.

Table 6-30. Code 26 - Auxiliary #2 - Short Circuit

STEP	ACTION	SPEC	YES	NO
1.	At the Ground Control Module, P1 connector, check the voltage across pins-8 and 1 to the Aux. #2 component. Is reading within specification?	0 - 2VDC	Go to Step 2	Replace Ground Control Module
2.	Remove the wire terminals at the Aux. #2 component, check continuity of each of the wires from pins-8 and 1 on the P1 connector to the Aux. #2 component end.	—	Replace the Component	Repair or Replace Wiring

 **Code 27 - Auxiliary #2 - Disconnected**

Check For These Obvious Conditions First:

- Is machine equipped with a component on the Auxiliary #2 circuit.

Table 6-31. Code 27 - Auxiliary #2 - Disconnected

STEP	ACTION	SPEC	YES	NO
1.	Is machine equipped with a component on the Auxiliary #2 circuit.	—	Go to Step 3	Got to Step 2
2.	At the Ground Control Module enter the programming mode, check if the Auxiliary #2 open circuit detection is enabled.	Default = NO	Disable It	Replace Ground Control Module
3.	Check voltage at the P1 connector on the Ground Control Module between pin-8 and pin-1. Is reading within specification?	2 - 4 VDC	Replace Ground Control Module	Go to Step 4
4.	Remove the wire terminals at the Aux. #2 component, check continuity of each of the wires from pins-8 and 1 on the P1 connector to the Aux. #2 component.	—	Replace the Component	Repair or Replace Wiring

 **Code 28 - Reserved**

 **Code 29 - Reserved**

 **Code 30 - Traction Module - No Communication with Ground Control Module**

Check For These Obvious Conditions First:

- Check if the communications cable connections, P5 connector on the Ground Control Module and round plug on the Traction Control Module are seated properly in their sockets at each end.
- Check the Positive (+) (RED) and Negative (-) (BLACK) power cable connections from the Ground Control Module to the Traction Control Module are tight and secure at both ends.

Table 6-32. Code 30 - Traction Module - No Communication with Ground Control Module

STEP	ACTION	SPEC	YES	NO
1.	Check the voltage reading at the main power Positive (+)/Negative (-) cable connection on the Traction Control Module.	24v DC	Go to Step 2	Repair or Replace Positive (+) or Negative (-) Cable
2.	Remove the communications cable, P5 connector at the Ground Control Module and round connector at the Traction Control Module. Check continuity of all three (3) wires in the communications cable from end to end. P5 - Pins 2, 3, and 4.	—	Go to Step 3	Repair or Replace Wire(s)
3.	With communications cable disconnected at both ends, check for continuity between Pins 2, 3, and 4 of the P5 connector end.	—	Repair or Replace Wires	Go to Step 4
4.	Plug the communications cable on the Traction Control Module to the round socket on the opposite end of the module. Does this fix problem?	—	Done	Replace Traction Control Module
5.	Unplug the P5 connector at the Ground Control Module. Check voltage between pins 2 (- lead-in) and 5 (+ lead-in). Is voltage within spec.	4.5v DC	Done	Replace Ground Control Module

Code 31 - Platform Control Console - No Communication with Ground Control Module

Check For These Obvious Conditions First:

- Check the harness connection at the P4 connector on the Ground Control Module and the harness connection at the other end on the Platform Junction Box.

Table 6-33. Code 31 - Platform Control Console - No Communication with Ground Control Module

STEP	ACTION	SPEC	YES	NO
1.	Check if LEDs are illuminated on the Platform Control Console.	—	Go To Step 2	Go to Step 3
2.	Remove the 9 pin Platform Control Console connector from the side of the Platform Junction Box and the P4 connector at the Ground Control Module. Check continuity from the P4 connector, pin-5 to Junction Box pin-3 and P4, pin-9 to Junction Box pin-4.	—	Repair or Replace Platform Control Console	Repair or Replace Wiring
3.	Remove the 9 pin Platform Control Console connector from the side of the Platform Junction Box. Check the voltage across pins-1 and 5 in the Junction Box connector.	24V DC	Repair or Replace Platform Control Console	Go to Step 4
4.	Check voltage across pins-10 and 2 on connector P4 at the Ground Control Module.	24V DC	Go to Step 5	Replace Ground Control Module
5.	Check continuity of P4 connector, pin-10 to Platform Junction Box pin-1. Also P4 connector, pin-2 to Platform Junction Box, pin-5.	—	Repair or Replace Wires	

Code 32 - Pump Motor - Over Current

Check For These Obvious Conditions First:

- Platform overload condition.
- Obstruction in mast system.
- Pump Positive (+) and Negative (-) connections are secure and undamaged.
- Crushed or kinked hydraulic lines.
- Hydraulic leaks.

Table 6-34. Code 32 - Pump Motor - Over Current

STEP	ACTION	SPEC	YES	NO
1.	Check current draw of pump motor by elevating the platform to full height and load pump by continuing to press the UP button. Is reading within spec?	Less than 145 Amps	Go to Step 2	Go to Step 3
2.	Did unit give a 32 Fault Code while performing Step 1?	—	Replace Ground Control Module	—
3.	Is the pump hydraulic pressure setting within specification as show in Section 1.6 of this Service Manual?	See Section 1.6	Go to Step 4	Adjust to Specification
4.	Check pump motor brushes and rotor commutator for abnormal wear.	—	Replace as Required	Replace Pump Motor

SECTION 6 - TROUBLESHOOTING

Code 33 - Both PHP Bars - UP

Table 6-35. Code 33 - Both PHP Bars - UP

STEP	ACTION	SPEC	YES	NO
1.	Perform steps in Code 2, Left PHP Bar UP then, Code 3, Right PHP Bar UP. Do either of these steps correct the problem?	—	Done	Go to Step 2
2.	Perform steps in Table 6-5 - Machine In Drive Speed Cut-Back (Turtle) Mode All The Time, of this section.	—	Done	Consult Factory

Code 34 - P2-Auxiliary #1 - Inhibit

Check For These Obvious Conditions First:

- Platform Gates Closed.
- Pressure on the Platform Foot-switch (*after power up*).

NOTE: In the procedures below, if you check continuity between pin 6 and 16 it should show open circuit, when the platform gates are closed and nothing is on the foot switch. When you step on the foot switch with the gates closed, you should see a closed circuit.

Table 6-36. Code 34 - P2-Auxiliary #1 - Inhibit

STEP	ACTION	SPEC	YES	NO
1.	At the Ground Control Module, P2 connector, check the voltage across pins-16 (orange/red 49-5) and 6 (black 12) is reading within specification?	0 - 2V DC	Go to Step 2	Replace Ground Control Module
2.	Remove the P2 connector from the Ground Station Module; check continuity of the individual wires in the platform harness. (<i>P2 to platform junction box</i>),	—	Go to Step 3	Repair or Replace Platform Harness
3.	Check continuity of gate switches and foot-switch circuit. (<i>Switches are wired in series; doors shut and foot switch depressed, circuit will be closed</i>)		Consult Factory	Replace Component or Repair Wires

Code 35 - P2-Auxiliary #1 - Tie Down

Check For These Obvious Conditions First:

- Pressure on the Platform Foot-switch during machine power up.

NOTE: In the procedures below, if you check continuity between pin 6 and 16 it should show open circuit, when the platform gates are closed and nothing is on the foot-switch. When you step on the foot switch with the gates closed, you should see a closed circuit.

Table 6-37. Code 35 - P2-Auxiliary #1 - Tie Down

STEP	ACTION	SPEC	YES	NO
1.	At the Ground Control Module, P2 connector, check the voltage across pins-16 (orange/red 49-5) and 6 (black 12) is reading within specification?	0 - 2V DC	Go to Step 2	Replace Ground Control Module
2.	Remove the P2 connector from the Ground Station Module; check continuity of the individual wires in the platform harness. (<i>P2 to platform junction box</i>),	—	Go to Step 3	Repair or Replace Platform Harness

Table 6-37. Code 35 - P2-Auxiliary #1 - Tie Down

3.	Check continuity of gate switches and foot switch circuit. <i>(Switches are wired in series; doors shut and foot switch depressed, circuit will be closed)</i>		Consult Factory	Replace Component or Repair Wires
----	--	--	-----------------	-----------------------------------

 **Code 38 - Battery Voltage Low - Warning Level 2 - Two (2) LED/LCDs lit**

To maximize battery life, it is recommended that the factory supplied batteries be charged continuously for a minimum of 4 hours or until 8 bars are lit on the ground station LCD Display before operating the machine. When drained to Warning Level 2, batteries must be charged until 8 bars are lit on the ground station LCD display to clear the fault code. Failure to do so, will result in a fault code 39.

 **Code 39 - Battery Voltage Low - Warning Level 3 - One (1) LED/LCDs lit**

To maximize battery life, it is recommended that the factory supplied batteries be charged continuously for a minimum of 4 hours or until 8 bars are lit on the ground station LCD Display before operating the machine. When drained to Warning Level 1, batteries must be charged until 8 bars are lit on the ground station LCD display to clear the fault code.

 Code 40 - Obstruction Sensor System - No Communication with Ground Control Module

Check For These Obvious Conditions First:

- Is machine equipped with an Obstruction Sensor System?
- Are the electrical harness connectors from the OSS Module through the Platform Junction Box to the Ground Control Module tight and undamaged?

Table 6-38. Code 40 - OSS - No Communication with Ground Control Module

STEP	ACTION	SPEC	YES	NO
1.	Is machine equipped with an OSS system?	—	Go to Step 4	Go to Step 2
2.	At the Ground Control Module, enter programming mode and view if OSS is enabled. Is OSS enabled?	X = No	Go to Step 3	Replace Ground Control Module
3.	In Service Level Programming mode, Disable Obstruction Sensor System.	X=No	—	—
4.	With machine powered up, check if the RED LED is lit on the front of the OSS Module.	—	Go to Step 5	Go to Step 10
5.	Check continuity from pin-9 on the OSS module (9-pin connector) to the platform junction box pin-2 (4-pin connector).	—	Go To Step 6	Inspect Wiring and Harness Connectors
6.	Check continuity from platform junction box pin-2 (4-pin connector) to the Ground Control Module (P-4 connector) pin-7.	—	Go to Step 7	Inspect Wiring and Harness Connectors
7.	Check continuity from pin-9 on OSS module (9-pin connector) to the Ground Control Module (P-4 connector) pin-7.	—	Go to Step 8	Inspect Connection at the Platform Junction Box
8.	Program the Ground Control Module to Disable the OSS System. Does fault condition still appear?	—	Replace the Ground Control Module	Go to Step 9
9.	Replace the Obstruction Sensor System and check for fault.	—	Replace the Ground Control Module	—
10.	Disconnect 9-pin connector at the OSS Module. Place a positive (+) lead on Pin-1 and a negative (-) lead on pin-5. Check for 24v DC.	24V (DC)	Replace the OSS Module	Go to Step 11
11.	Check the wiring harness from the Platform Junction Box connector to the Ground Control Module, positive (+) lead on pin-1 to negative (-) lead on pin-4. Check for 24v DC.	24V (DC)	Repair or Replace, OSS to Junction Box Wire Harness	Go to Step 12
12.	At the Ground Control Module (P-4 connector) check voltage between pin-8 and pin-2, place positive (+) lead on pin-8.	24V (DC)	Repair or Replace, Junction Box to Ground Control Module Wire Harness	Replace Ground Control Module

 **Codes 41 thru 46 - OSS - Sensor 1 through 6 - Fault Condition**
Check For These Obvious Conditions First:

- Is there an obstruction under the sensor showing the fault?
- Is the faulted sensor mounted properly and securely to the platform base frame?

Table 6-39. Codes 41 thru 46 - OSS - Sensor 1 through 6 - Fault Condition

STEP	ACTION	SPEC	YES	NO
1.	Is machine equipped with an OSS system?	—	Go to Step 4	Go to Step 2
2.	At the Ground Control Module, enter programming mode and view if OSS is enabled. Is OSS enabled?	X = No	Go to Step 3	Replace Ground Control Module
3.	In Service Level Programming mode, Disable Obstruction Sensor System.	X=No	—	Go to Step 4
4.	Replace the sensor showing the fault. Does this correct the problem.	—	Done	Go to Step 5
5.	Replace the complete OSS system, module and sensors.	—	—	—

 Codes (100 - 199) Ground Control Module - Fault Condition

Check For These Obvious Conditions First:

- That all battery and harness connectors secure and undamaged on Ground Control Module.
- Batteries have sufficient charge.
- Confirm that the static ground strap attached under base frame is secure and undamaged.

Table 6-40. Codes (100 - 199) Ground Control Module - Fault Condition

STEP	ACTION	SPEC	YES	NO
1.	Recycle machine power 5 times allowing a 10 second interval between each power recycle. Does fault clear?	—	Done	Go to Step 2
2.	Which code number is displaying?	Code 103	Go to Step 3	Replace Ground Control Module
		Code 119	Go to Step 5	
3.	Confirm that both installed batteries are 12 Volt DC.	12V DC	Go to Step 4	Replace with proper Batteries
4.	Check battery voltage while charger is operating. Is voltage within specification?	Maximum of 31 Volts DC	Replace Ground Control Module	Repair or Replace Battery Charger
5.	Remove the communications cable, P5 connector at the Ground Control Module and round connector at the Traction Control Module. Check continuity of all three (3) wires in the communications cable from end to end. P5 - Pins 2, 3, and 4.	—	Go to Step 6	Repair or Replace Wire(s)
6.	With communications cable still disconnected at both ends, check for continuity between Pins 2, 3, and 4 at the P5 connector end.	—	Repair or Replace Wires	Go to Step 7
7.	Plug the communications cable on the Traction Control Module to the round socket on the opposite end of the module. Does this fix problem?	—	Done	Replace Ground Control Module

 **Codes (200 - 299) Platform Control Console - Fault Condition**

Check For These Obvious Conditions First:

- Damage to Platform Control Console wiring harness.
- Secure harness connections from Platform Control Console to Platform Junction Box to Ground Control Module.
- Confirm that the static ground strap attached under base frame is secure and undamaged.

Table 6-41. Code (200 - 299) Platform Control Console - Fault Condition

STEP	ACTION	SPEC	YES	NO
1.	Recycle machine power 5 times allowing a 10 second interval between each power recycle. Does fault clear?	—	Done	Go to Step 2
2.	Which 200 code number is displaying?	Code - 200/207/213	Go to Step 3	Replace Platform Control Module
		Code - 202/205/206	Go to Step 4	
3.	Remove the 9 pin Platform Control Module connector from the side of the Platform Junction Box and the P4 connector at the Ground Control Module. Check continuity from the P4 connector, pin-5 to Junction Box pin-3 and P4, pin-9 to Junction Box pin-4. Is there continuity on these wires?	—	Replace Platform Control Module	Repair or Replace Wiring
4.	Perform the Joystick Calibration Procedure in Section 4.5 of this Service Manual. Does this clear the fault code?	—	Done	Replace Platform Control Module

SECTION 6 - TROUBLESHOOTING

Codes (300 - 399) Traction Control Module - Fault Condition

Check For These Obvious Conditions First:

- Damage to Traction Control Module wiring harness.
- Confirm that the static ground strap attached under base frame is secure and undamaged.

Table 6-42. Codes (300 - 399) Traction Control Module - Fault Condition

STEP	ACTION	SPEC	YES	NO
1.	Recycle machine power 5 times allowing a 10 second interval between each power recycle. Does fault clear?	—	Done	Go to Step 2
2.	Is a code number displaying on the Ground Control Station?	Code - 316	Go to Step 3	Replace Traction Control Module
		Code - 325	Go to Step 5	—
3.	Confirm that both installed batteries are 12 Volt DC.	12V DC	Go to Step 4	Replace with proper Batteries
4.	Check battery voltage while charger is operating. Is voltage within specification?	Maximum of 31 Volts DC	Replace Traction Control Module	Repair or Replace Battery Charger
5.	Check for short in harness wires from Ground Control Station connector P5 to Traction Module (<i>round din plug</i>). <i>Note: This harness contains 6 wires only 3 are used, (See Figure 6-7.) Electrical Diagram.</i>	—	Repair or Replace Wiring	—

6.12 MAIN POWER CIRCUIT TROUBLESHOOTING

Machine Will Not Power Up

Check For These Obvious Conditions First:

- Battery voltage is 24 volts. (Sufficient Charge in Batteries to Operate Machine)
- Positive (+) and negative (-) battery cable connections clean and tight at both the Batteries and the Ground Control Module lugs.
- Main Power Selector Switch (key) positioned to either Platform or Ground Control Mode.
- Emergency stop buttons on both the Ground Control Module and the Platform Control Console in the RESET position (out).

Table 6-43. Machine Will Not Power UP.

STEP	ACTION	SPEC	YES	NO
1.	Check for 24V DC at the positive (+) and negative (-) main power cable connections on the Ground Control Module.	24V DC	Go to Step 2	Replace the 175 Amp Inline Fuse on the Positive power cable
2.	Check continuity of the Emergency Stop wires running to the Platform Control Console, pins-10 and 1 on the P4 connector at the Ground Control Module.	—	Replace the Ground Control Module	Go to Step 3
3.	Remove the 9-pin Platform Control Console connector at the Platform Junction Box and check continuity between pins-1 and 2 to the Emergency Stop Switch in the Platform Control Console cable.	—	Go to Step 4	Replace the Platform Control Console
4.	Check continuity of the wires running from the P4 connector on Ground Control Module to the Platform Junction Box; P4 connector, Pin-1 to Junction Box Pin-2 and P4 connector, Pin-10 to Junction Box Pin-1	—	Replace Platform Control Console	Repair or Replace Wiring

6.13 MAST TROUBLESHOOTING

Platform Will Not Lower Manually

Check For These Obvious Conditions First:

- Is there an obstruction in the mast assembly?
- Is there a restricted hydraulic line (smashed)?
- Are the mast slide pads shimmed properly (not too tight), per Mast Assembly procedure in Service Manual?

Table 6-44. Platform Will Not Lower Manually.

STEP	ACTION	SPEC	YES	NO
1.	Check to see if the platform will lower from the Ground Control Station in Ground Control Mode.	—	Repair or Replace the Manual Descent Control Valve	Go to Step 2
2.	Check to see if the lift down valve is opening completely.	—	Go to Step 3	Replace the Lift Down Valve
3.	Check the flow valve in the lift cylinder for a restriction.	—	Clean or Replace Flow Valve	Consult Factory

Platform Lift Up And Down - Jerky

Overview Of Procedure

The following procedure suggests areas on the machine which might attribute to erratic movement of the platform during lift up and down.

Check For These Obvious Conditions First:

- If mast is not running smooth or has tight and rough spots, refer to the Mast Section Rebuild.
- Hydraulic oil level in reservoir tank at full level.
- Hydraulic oil is not milky (presence of water), or foamy (full of air).

Table 6-45. Platform Lift Up and Down Jerky

STEP	ACTION	SPEC	YES	NO
CONTROLS (ELECTRICAL)				
1.	Is platform control console, platform enable, up or down pad defective or worn out?	—	Replace pad	Go to Step 2
2.	Loose connections, ground and power.	—	Repair connection	Go to Step 3
3.	Valve solenoid keeps opening and closing.	—	Repair Connection or Replace Valve	Go to Step 4
4.	Problem internal to the Ground Control Module.	—	Replace Module	Go to Step 5
HYDRAULIC				
5.	Is the hydraulic valve working properly.	—	Go to Step 6	Replace Valve
6.	Pump drive cavating.	—	Replace Pump	Go to Step 7
7.	Lift cylinder	—	Rebuild or Replace Cylinder	—

Mast Noisy When Lifting And Lowering

Overview Of Procedure

This procedure examines components of the mast itself and as well as it's lifting components for dirt, debris, proper lubrication and operation.

Table 6-46. Mast Noisy when Lifting and Lowering.

STEP	ACTION	SPEC	YES	NO
1.	Do slide pads and slide pad channels need to be cleaned of dust, dirt, or other debris?	—	Clean Pads and Channels	Go to Step 2
2.	Do mast chains need to be lubricated per JLG specification in the Service Manual?	—	Lubricate as Required	Go to Step 3
3.	Are the chain/cable sheave wheels dry and need lubrication? Note: Plastic wheels will howl on the sheave pin when they are dry. Sheave wheels may seize to the sheave pin and the pin may turn in the pin retainer blocks.	—	Lubricate or Replace Sheave Pins and Wheels	Go to Step 4
4.	Are the sequence cables (located on the side of mast) chattering when the springs are compressed? Note: This noise is normal at the sequence cable sheave wheels when the mast is completely lowered. However if the sequence cable chattering is happening no matter what position the mast is in, it could be a result of the mast being shimmed to tight or dirt and debris in the slide pad channels causing the mast to be tight.	—	Clean Slide Pads/ Channels or Re-shim Mast per Service Manual	Go to Step 5
5.	Is the bore of the lift cylinder dry?	—	Replace Packing or Lift Cylinder	Go to Step 6
6.	Are the bearings in the lift pump motor and pump drive worn?	—	Repair or Replace Pump	Go to Step 7
7.	Are the hydraulic lines vibrating together?	—	Adjust the Position of the Lines	Go to Step 8
8.	Check if the pump motor is loose to it's mounting plate.	—	Tighten pump mounting fasteners	Go to Step 9
9.	Hydraulic oil could be cavatating inside the pump.	—	Repair or Replace Pump	—

Platform (Mast) Won't Stay Elevated

Overview Of Procedure

The following procedure requests that the lift down, dump, and pump internal valves be checked to see if any are stuck open, it also examines the lift down and dump valve circuits. Also suggests that the lift cylinder packing could be leaking internally.

Check For These Obvious Conditions First:

- Manual descent valve is closed tight.

Table 6-47. Platform (Mast) Won't Stay Elevated.

STEP	ACTION	SPEC	YES	NO
1.	Is the lift down valve stuck open?	—	Repair or Clean Valve	Go to Step 2
2.	Lift down valves could be open due to incorrect electrical signal.	—	Check Pump Valve Electrical Circuit	Go to Step 3
3.	Oil could be passing around the lift cylinder bore packing.	—	Replace or Rebuild the Lift Cylinder	—

Platform (Mast) Descends Too Slowly

Overview Of Procedure

The following procedure examines the mast some hydraulic components for obstructions and defects.

Table 6-48. Platform (Mast) Descends Too Slowly.

STEP	ACTION	SPEC	YES	NO
1.	Check mast slide pads shimmed to tight.	—	Reshim Mast	Go to Step 2
2.	Is there an obstruction in the mast?	—	Remove Obstruction	Go to Step 3
3.	The lift cylinder packing could be too tight in the bore of the cylinder barrel.	—	Rebuild or Replace Cylinder	Go to Step 4
4.	Check if the lift down valve is opening completely.	—	Clean or Replace Valve	Go to Step 5
5.	Is there a restricted hydraulic line (smashed)?	—	Replace Hydraulic Line	Go to Step 6
6.	Check the flow valve in the cylinder valve block for a restriction, i.e. dirt.	—	Clean or Replace Flow Valve	—

6.14 HYDRAULIC LEAK TROUBLESHOOTING

Miscellaneous Hydraulic Leak Troubleshooting

Overview Of Procedure

This series of steps gives remedies for various areas of the machine where leaks could occur.

Table 6-49. Hydraulic Leak Troubleshooting

STEP	ACTION	SPEC	YES	NO
1.	Oil leaking around the lift cylinder rod.	—	Replace the Seal at the end of the Piston and Cylinder Barrel	—
2.	Oil leaking around the cylinder extend or return line fittings.	—	Tighten or Replace Fittings	—
3.	Oil leaking around the hydraulic lines.	—	Tighten or Replace Hydraulic Lines	—
4.	Oil leaking around the lift down valve.	—	Tighten Cartridge in Pump Case	—
5.	Oil leaking around the (Red) manual descent valve.	—	Replace Lift Down Valve	—
<p>Note: Do not overtighten the nut on the solenoid in step 5.</p>				

6.15 BASE FRAME COMPONENTS TROUBLESHOOTING

Caster Wheels Not Operating Freely

Check For These Obvious Conditions First:

- Is machine operating on a smooth, level surface?

Table 6-50. Caster Wheels Not Operating Freely.

STEP	ACTION	SPEC	YES	NO
1.	Is the caster rotating freely?	—	Go to Step 2	Lubricate or Replace Caster Housing
2.	Is the wheel spinning freely?	—	Go to Step 3	Lubricate or Replace Wheel
3.	Is debris stuck in the rubber wheel?	—	Remove Debris or Replace Wheel	—

Pot Hole Protection (PHP) Bars will not Lower

Check For These Obvious Conditions First:

- Obstruction under pot hole bar on either side of machine.
- Obstruction around the actuator assembly at the base of the mast.

Table 6-51. Pot Hole Protection (PHP) Bars will not Lower.

STEP	ACTION	SPEC	YES	NO
1.	Check the actuator assembly and cables for adjustment or damage.	—	Adjust or Replace	Consult Factory

6.16 DRIVE SYSTEM TROUBLESHOOTING

Won't Climb Grade

Overview Of Procedure

The following procedure checks the drive motor and attached components for component failure, misadjustment due to wear.

Check For These Obvious Conditions First:

- Batteries are Fully Charged (24 Volts)
- Speed Control is Set to Maximum
- Is Grade within the Maximum Allowable Specification of 20% Grade
- Does the Travel Surface allow for Proper Drive Wheel Traction
- Is Platform Load within the Maximum Rated Capacity

Table 6-52. Won't Climb Grade

STEP	ACTION	SPEC	YES	NO
1.	Does machine drive straight on a level surface?	—	Go to Step 2	Refer to Machine Won't Drive Straight (Table 6-54)
2.	Do the left and right drive motor brakes release properly and allow the drive wheels to rotate freely?	—	Go to Step 3	Dragging? Repair, Replace or Adjust Brakes
3.	Check the amperage output of the on the drive motor leads. They should not exceed 100 amps while pulling a grade.	—	Controller will Shut Drive Down and will flash a 7 LED Code	Go to Step 5
4.	Check the condition of the drive motor brushes.	—	OK, go to Step 6	Worn down, replace brushes or drive motor
5.	If all above is OK, Drive motors are working properly. Consult Factory.	—	—	—

Machine Drives in Opposite Direction

Table 6-53. Machine Drive in Opposite Direction

STEP	ACTION	SPEC	YES	NO
1.	At the Traction Control Module, check if the left drive motor power lead is plugged into the M1 socket.	—	Go to Step 2	Switch the Left and Right Drive Motor Power Leads at the Traction Module
2.	Remove the Right Drive Motor power lead at the Traction Control Module (M2) and check if the WHITE wire is connected to the positive (+) terminal and the BLACK wire is connected to the negative (-) terminal. (Reference Figure 6-7., Electrical Diagram. (MVL/MSP)	—	Go to Step 3	Rewire as Necessary
3.	Remove the Left Drive Motor power lead at the Traction Control Module (M1) and check if the BLACK wire is connected to the positive (+) terminal and the WHITE wire is connected to the negative (-) terminal. The Left Motor Power lead is reversed from the Right Motor lead due to the reverser harness. (Reference Figure 6-7., Electrical Diagram. (MVL/MSP)	—	Consult Factory	Rewire as Necessary

Machine Won't Drive Straight

Overview Of Procedure

The following procedure examines the drive motor assembly weldments attaching the drive motors to the base frame. Also internal components of the drive motors, gear box and a check of the components between the gear box and the drive wheels.

Check For These Obvious Conditions First:

- Battery voltage 24 volts. (Fully charge batteries)
- Nothing is lodged between one of the wheels and the base frame.
- A caster wheel on the front of the machine is seized up, creating resistance.

Table 6-54. Machine Won't Drive Straight.

STEP	ACTION	SPEC	YES	NO
1.	Check for the following on the drive assembly, drive attachment weldments; is bent, has broken welds, or loose hardware.	—	Repair/Replace/ Tighten weldment	Go to Step 2
2.	Check for the following on the drive assembly, drive motor mounting plates; are bent, are square with drive weldments, or is hardware loose?	—	Repair/Replace/ Tighten weldment	Go to Step 3
3.	Check for the following on the drive assembly, drive motor hardware; is hardware loose.	—	Repair/Replace/ Tighten component	Go to Step 4
4.	Check the left and right drive motor brakes for loose hardware & not releasing properly.	—	Tighten or Adjust per procedure in this Service Manual	Go to Step 5
5.	Is the electrical signal and amperage draw to the drive motors equal? Check with machine on level surface.	See Table 6-3.	Recheck Steps 1 thru 5	Go to Step 6
6.	Check the drive motor brushes, do they need replaced?	—	Replace per procedure in this Service Manual	Go to Step 7
7.	Is joystick control defective? If possible, swap out with another platform control.	—	Repair/Replace Platform control	Go to Step 8
8.	Is the Traction Control Module defective or connections not tight? If possible, swap out with another Traction Control Module.	—	Tighten Connec- tions or Replace Traction Control Module	Go to Step 9
9.	Inside the drive motor gear box check if; the drive shaft is excessively loose & condition of drive shaft bearings. Are any gears broken or gear teeth excessively worn.	—	Repair/Replace gear box components per procedure in this Service Manual	

Noise From Drive Assembly

Overview Of Procedure

The following procedure examines the drive motor assembly weldments attaching the drive motors to the base frame. Also internal components of the drive motors, gear box and a check of the components between the gear box and the drive wheels.

Check For These Obvious Conditions First:

- Battery voltage 24 volts. (Fully charge batteries)
- Nothing is lodged between one of the wheels and the base frame.
- A caster wheel on the front of the machine is seized up, creating resistance.

Table 6-55. Noise from Drive Assembly.

STEP	ACTION	SPEC	YES	NO
1.	Check for the following on the drive assembly, drive attachment weldment; is bent, has broken welds, or loose hardware.	—	Repair/Replace/ Tighten weldment	Go to Step 2
2.	Check for the following on the drive assembly, drive motor mounting plates; are bent, are square with drive weldments, or is hardware loose?	—	Repair/Replace/ Tighten weldment	Go to Step 3
3.	Check for the following on the drive assembly, drive motor hardware; is hardware loose.	—	Repair/Replace/ Tighten Component	Go to Step 4
4.	Check the left and right drive motor brakes for loose hardware & not releasing properly.	—	Tighten or Adjust per procedure in this Service Manual	Go to Step 5
5.	Is the electrical signal and amperage draw to the drive motors equal? Check with machine on level surface.	See Table 6-3.	Recheck Steps 1 thru 5	Go to Step 6
6.	Check the drive motor brushes, do they need replaced?	—	Replace per procedure in this Service Manual	Go to Step 7
7.	Inside the drive motor gear box check if; the drive shaft is excessively loose & condition of drive shaft bearings. Are any gears broken or gear teeth excessively worn.	—	Repair/Replace gear box components per procedure in this Service Manual	

SECTION 6 - TROUBLESHOOTING

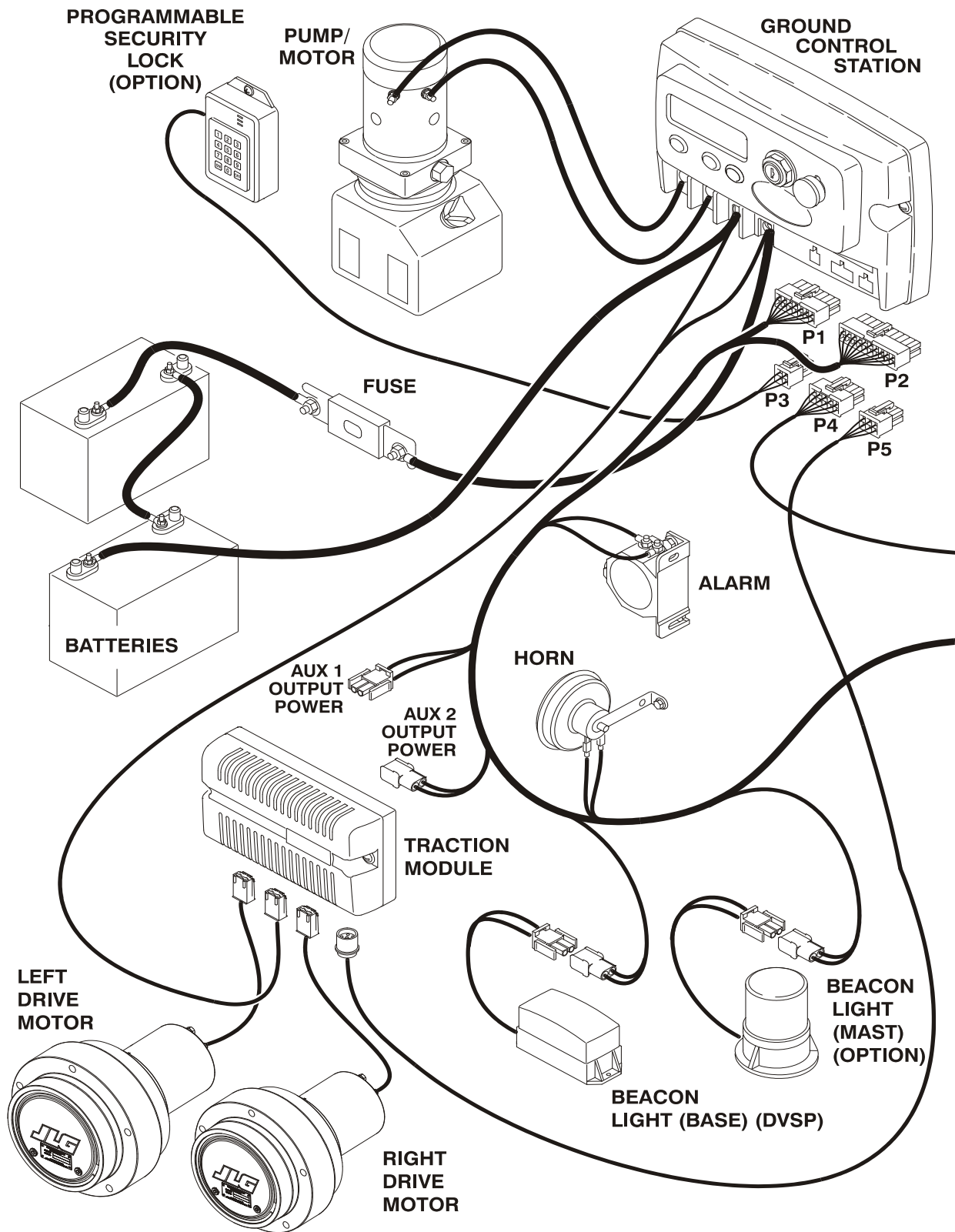

Figure 6-6. Overview of Electrical System Components. (MVL/MSP) (Sheet 1 of 2)

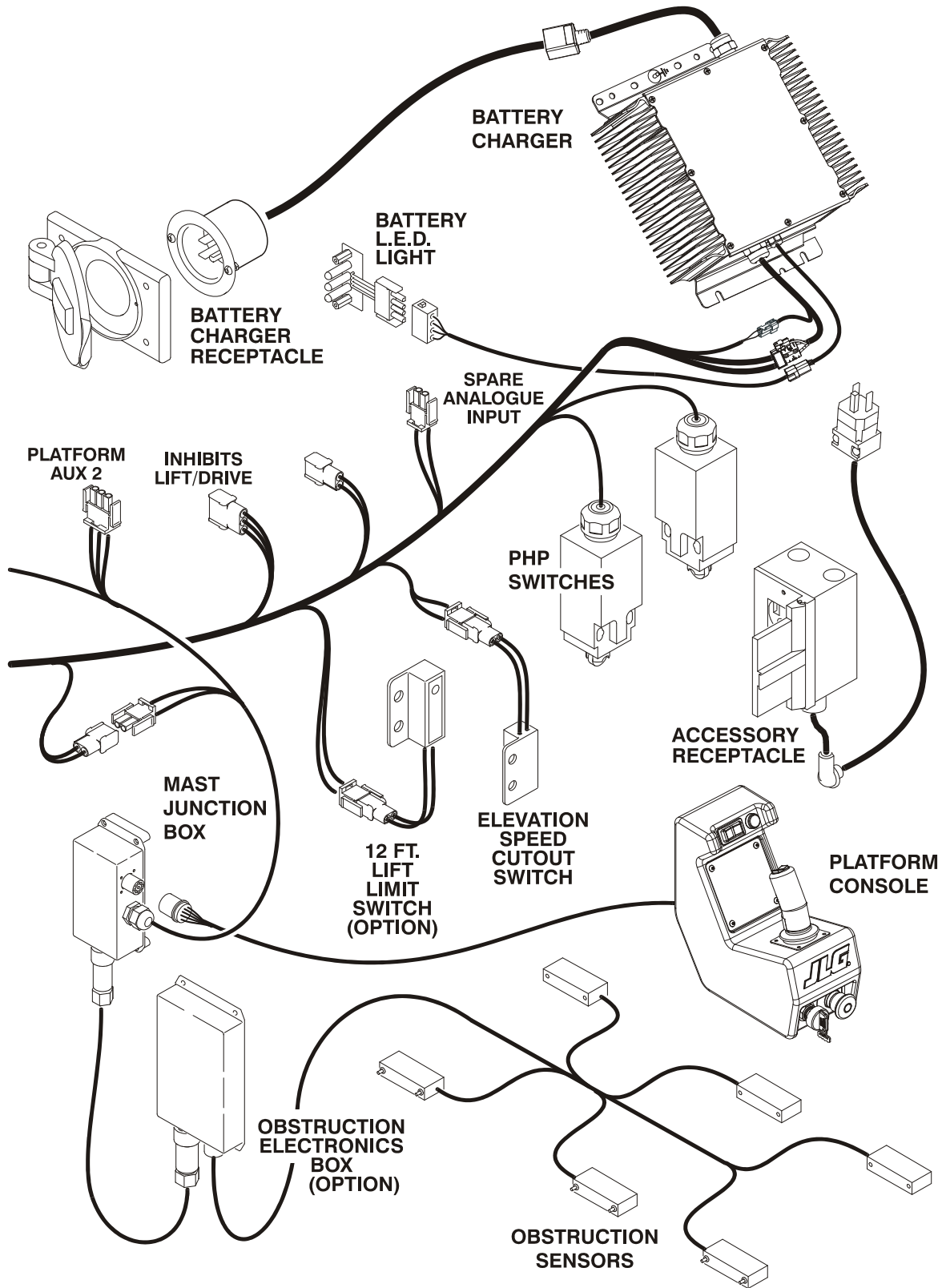

Figure 6-2. Overview of Electrical System Components. (MVL/MSP) (Sheet 2 of 2)

SECTION 6 - TROUBLESHOOTING

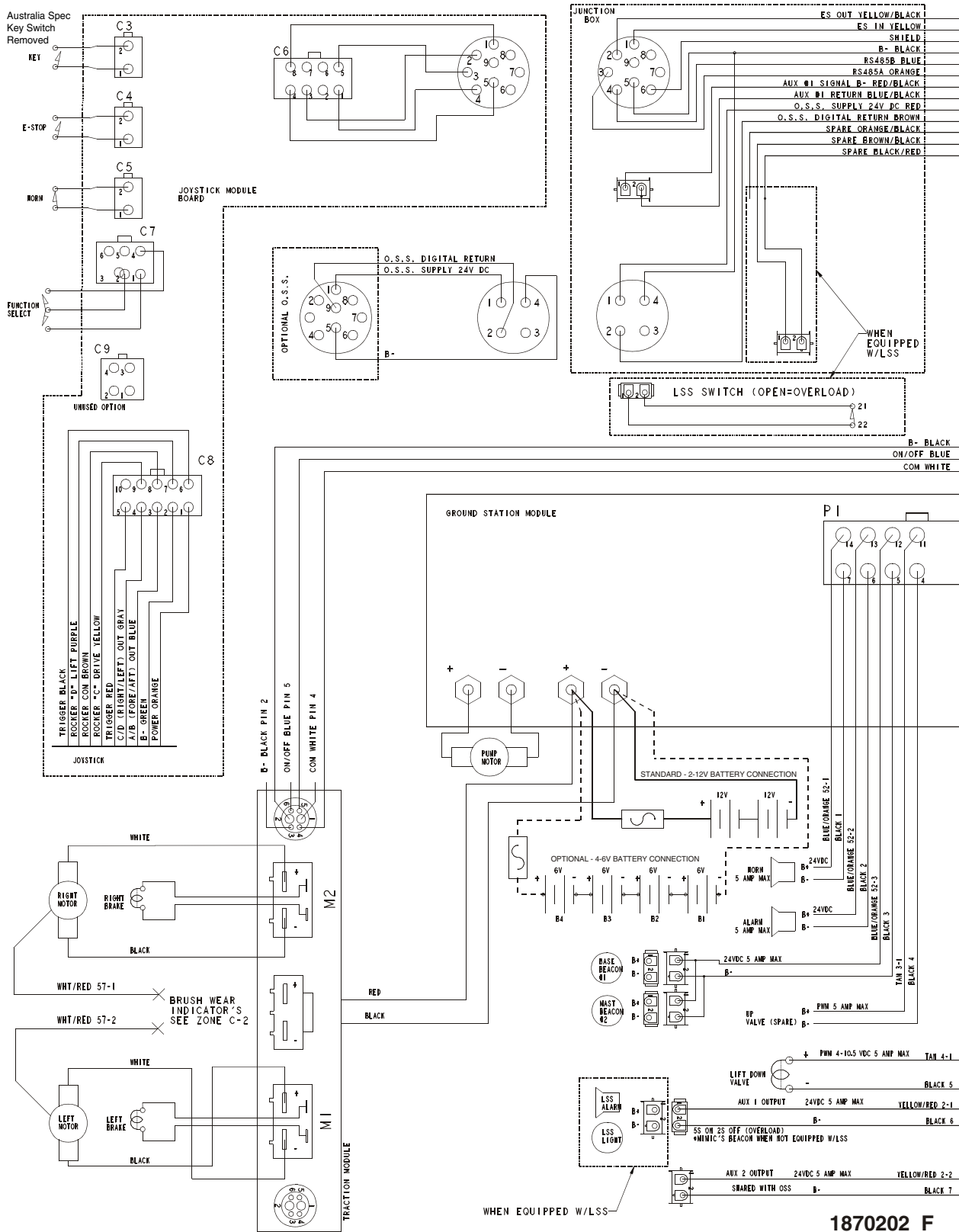
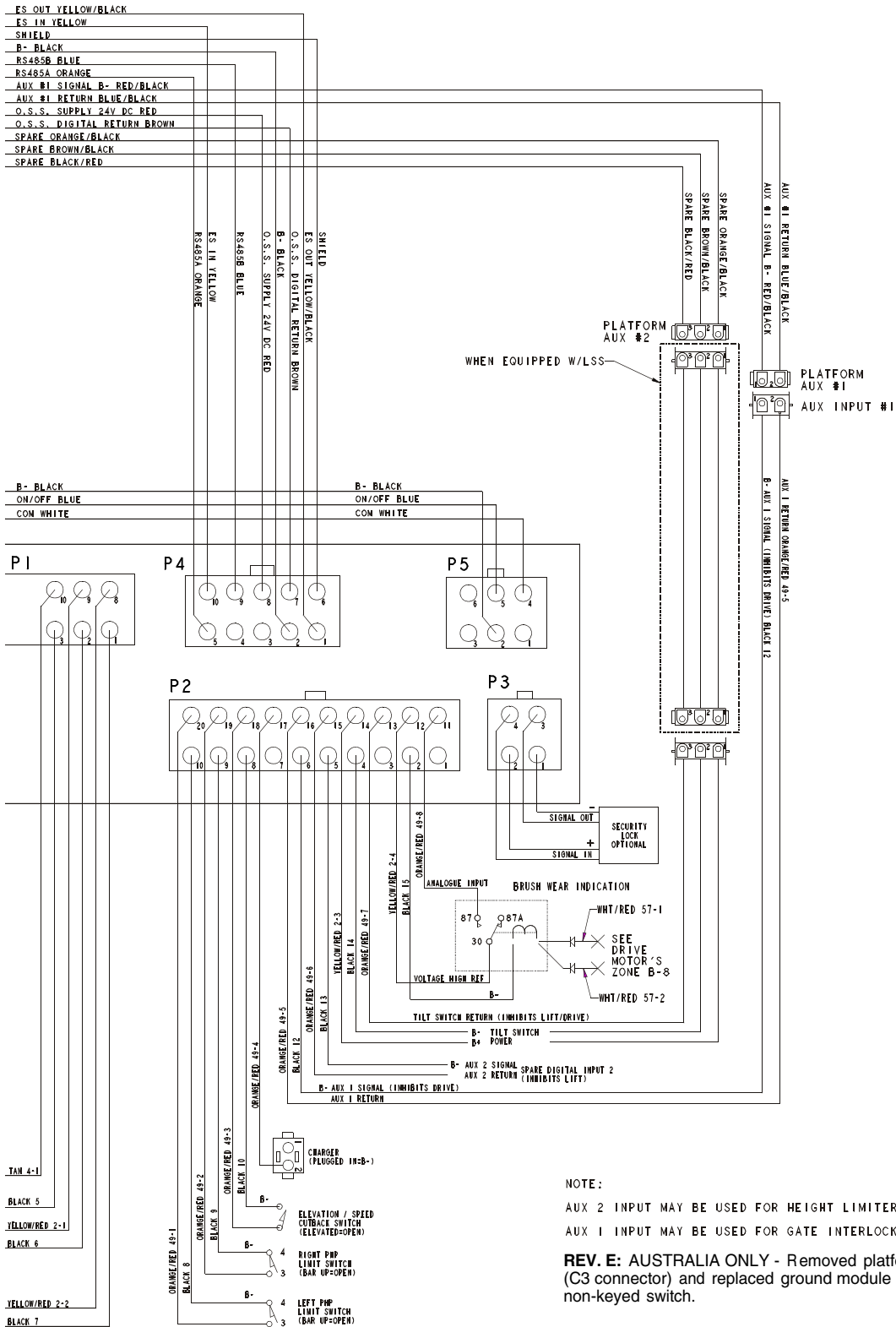

Figure 6-7. Electrical Diagram. (MVL/MSP)

1870202_F



NOTE:
 AUX 2 INPUT MAY BE USED FOR HEIGHT LIMITERS
 AUX 1 INPUT MAY BE USED FOR GATE INTERLOCK

REV. E: AUSTRALIA ONLY - Removed platform module keyswitch (C3 connector) and replaced ground module key switch with non-keyed switch.

1870202_F

Figure 6-3. Electrical Diagram. (MVL/MSP)

SECTION 6 - TROUBLESHOOTING

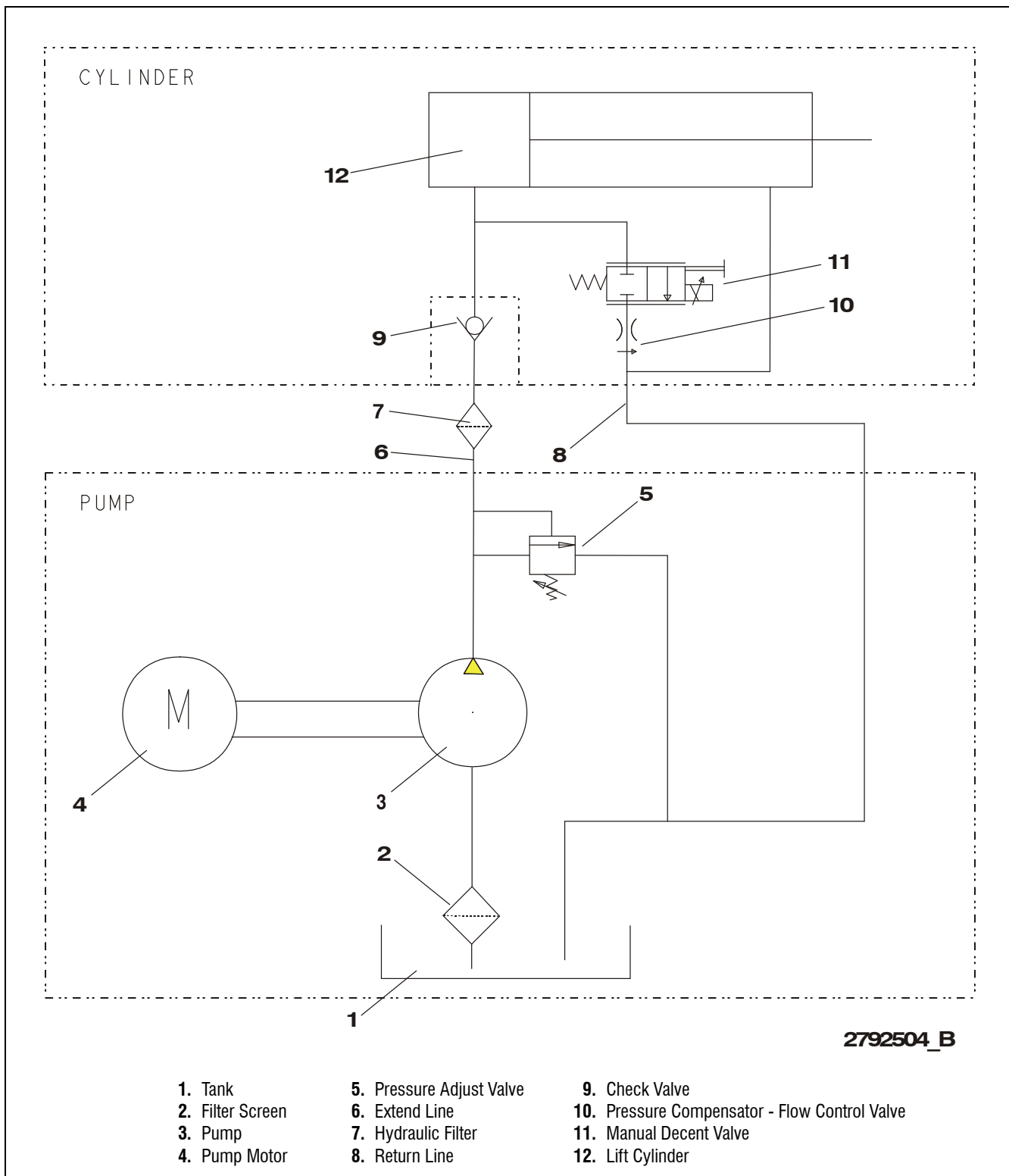

Figure 6-8. Hydraulic Diagram. (MVL/MSP)

**CALIFORNIA PROPOSITION 65
BATTERY WARNING**

**Battery posts, terminals
and related accessories
contain lead and lead
compounds, chemicals
known to the State of
California to cause cancer
and reproductive harm.**

**Batteries also contain other
harmful chemicals known
to the State of California.**

**WASH HANDS
AFTER HANDLING!**



An Oshkosh Corporation Company

Corporate Office
JLG Industries, Inc.
1 JLG Drive
McConnellsburg PA. 17233-9533
USA
☎ **(717) 485-5161(Corporate)**
☎ **(877) 554-5438(Service)**
📠 **(717) 485-6417**

JLG Worldwide Locations

JLG Industries
358 Park Road
Regents Park
NSW 2143
Sydney 2143
Australia
☎ +6 (12) 87186300
📠 +6 (12) 65813058
Email: techservicesauc@jlg.com

JLG Ground Support Oude
Bunders 1034
Breitwaterstraat 12A
3630 Maasmechelen
Belgium
☎ +32 (0) 89 84 82 26
Email: emeaservice@jlg.com

JLG Latino Americana LTDA
Rua Antonia Martins Luiz, 580
Distrito Industrial Joao Narezzi
Indaiatuba-SP 13347-404
Brasil
☎ +55 (19) 3936 7664 (Parts)
📠 +55(19)3936 9049 (Service)
Email: comercialpecas@jlg.com
Email: servicos@jlg.com

Oshkosh-JLG (Tianjin)
Equipment Technology LTD
Shanghai Branch
No 465 Xiao Nan Road
Feng Xian District
Shanghai 201204
China
☎ +86 (21) 800 819 0050

JLG Industries Dubai
Jafza View
PO Box 262728, LB 19
20th Floor, Office 05
Jebel Ali, Dubai
☎ +971 (0) 4 884 1131
📠 +971 (0) 4 884 7683
Email: emeaservice@jlg.com

JLG France SAS
Z.I. Guillaume Mon Amy
30204 Fauillet
47400 Tonniens
France
☎ +33 (0) 553 84 85 86
📠 +33 (0) 553 84 85 74
Email: pieces@jlg.com

JLG Deutschland GmbH
Max Planck Str. 21
27721 Ritterhude - Ihlpohl
Germany
☎ +49 (0) 421 69350-0
📠 +49 (0) 421 69350-45
Email: german-parts@jlg.com

JLG Equipment Services Ltd.
Rm 1107 Landmark North
39 Lung Sum Avenue
Sheung Shui N. T.
Hong Kong
☎ +(852) 2639 5783
📠 +(852) 2639 5797

JLG Industries (Italia) S.R.L.
Via Po. 22
20010 Pregnana Milanese (MI)
Italy
☎ +39 (0) 2 9359 5210
📠 +39 (0) 2 9359 5211
Email: ricambi@jlg.com

JLG EMEA B.V.
Polaris Avenue 63
2132 JH Hoofddorp
The Netherlands
☎ +31 (0) 23 565 5665
Email: emeaservice@jlg.com

JLG NZ Access Equipment &
Services
2B Fisher Crescent
Mt Wellington 1060
Auckland, New Zealand
☎ +6 (12) 87186300
📠 +6 (12) 65813058
Email: techservicesaus@jlg.com

JLG Industries
Vahutinskoe shosse 24b.
Khimki
Moscow Region 141400
Russia Federation
☎ +7 (499) 922 06 99
📠 +7 (499) 922 06 99

Oshkosh-JLG Singapore
Technology Equipment Pte Ltd.
35 Tuas Avenue 2
Jurong Industrial Estate
Singapore 639454
☎ +65 6591 9030
📠 +65 6591 9045
Email: SEA@jlg.com

JLG Iberica S.L.
Trapadella, 2
Pol. Ind. Castellbisbal Sur
08755 Castellbisbal
Barcelona
Spain
☎ +34 (0) 93 772 47 00
📠 +34 (0) 93 771 1762
Email: parts_iberica@jlg.com

JLG Sverige AB
Enkopingsvagen 150
176 27 Jarfalla
Sweden
☎ +46 (0) 8 506 595 00
📠 +46 (0) 8 506 595 27
Email: nordicsupport@jlg.com

JLG Industries (UK) Ltd.
Bentley House
Bentley Avenue
Middleton, Greater Manchester
M24 2GP
United Kingdom
☎ +44 (0) 161 654 1000
📠 +44 (0) 161 654 1003
Email: ukparts@jlg.com